



Civinnovate

Discover, Learn, and Innovate in Civil Engineering

Mechanics

It is defined as that branch of science, which describes and predicts the conditions of rest or motion of bodies under the action of forces. Engineering mechanics applies the principle of mechanics to design, taking into account the effects of forces.

Statics

Statics deal with the condition of equilibrium of bodies acted upon by forces.

Rigid body

A rigid body is defined as a definite quantity of matter, the parts of which are fixed in position relative to each other. Physical bodies are never absolutely but deform slightly under the action of loads. If the deformation is negligible as compared to its size, the body is termed as rigid.

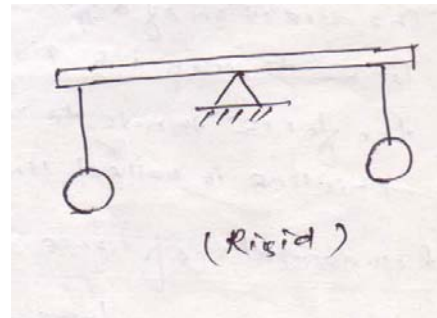
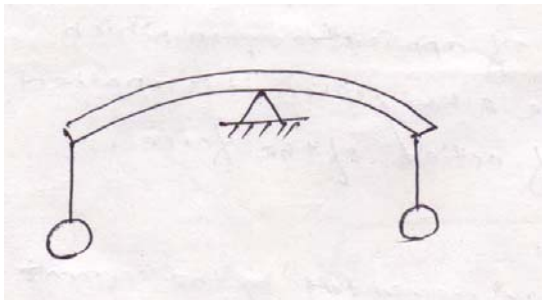

Force

Force may be defined as any action that tends to change the state of rest or motion of a body to which it is applied.

The three quantities required to completely define force are called its specification or characteristics. So the characteristics of a force are:

1. Magnitude
2. Point of application
3. Direction of application

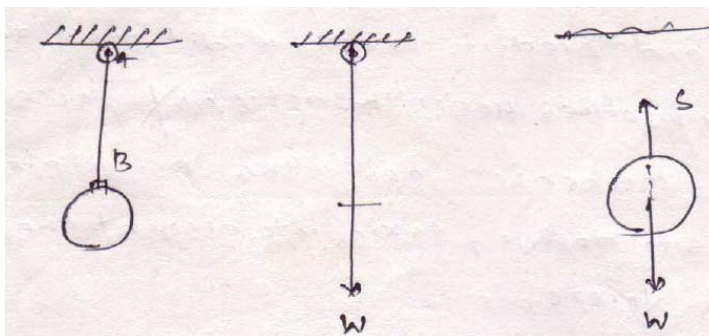

Concentrated force/point load

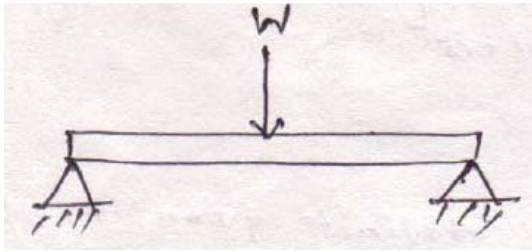

Distributed force

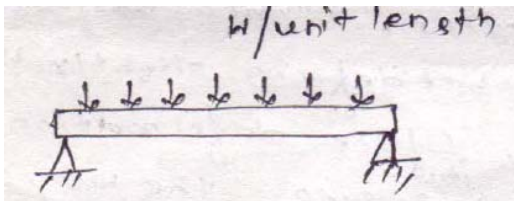

Line of action of force

The direction of a force is the direction, along a straight line through its point of application in which the force tends to move a body when it is applied. This line is called line of action of force.

Representation of force

Graphically a force may be represented by the segment of a straight line.

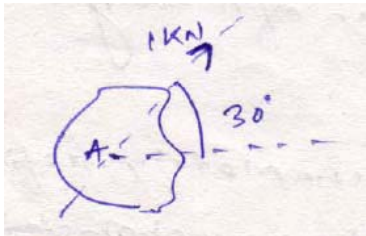

Composition of two forces

The reduction of a given system of forces to the simplest system that will be its equivalent is called the problem of composition of forces.

Parallelogram law

If two forces represented by vectors AB and AC acting under an angle α are applied to a body at point A. Their action is equivalent to the action of one force, represented by vector AD, obtained as the diagonal of the parallelogram constructed on the vectors AB and AC directed as shown in the figure.

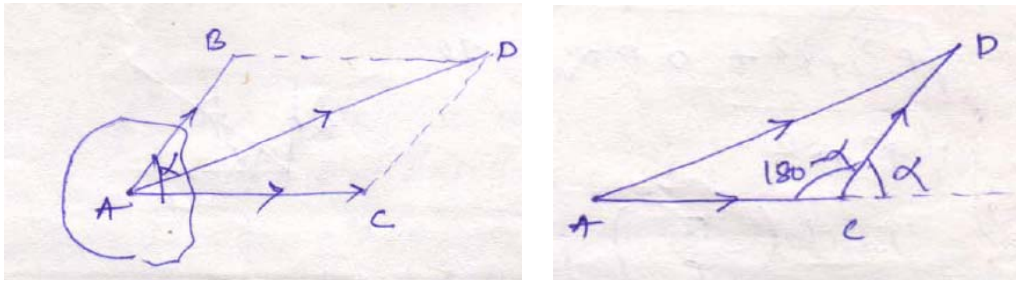

Force AD is called the resultant of AB and AC and the forces are called its components.

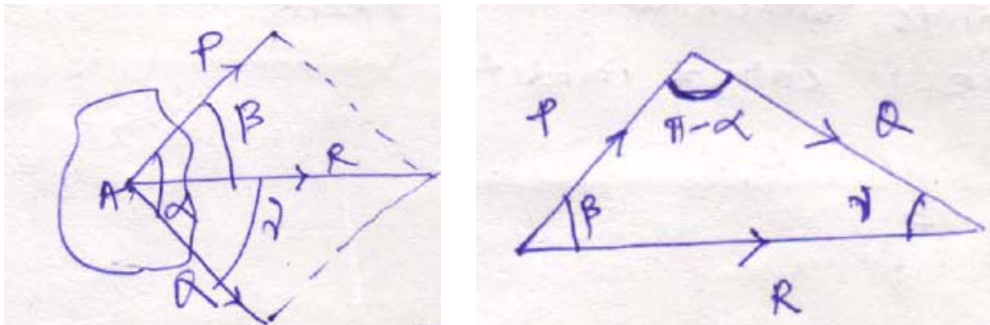

$$R = \sqrt{(P^2 + Q^2 + 2PQ \times \cos\alpha)}$$

Now applying triangle law

$$\frac{P}{\sin\gamma} = \frac{Q}{\sin\beta} = \frac{R}{\sin(\pi - \alpha)}$$

Special cases

Case-I: If $\alpha = 0^\circ$

$$R = \sqrt{(P^2 + Q^2 + 2PQ \times \cos 0^\circ)} = \sqrt{(P+Q)^2} = P+Q$$

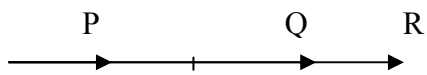

$$R = P+Q$$

Case- II: If $\alpha = 180^\circ$

$$R = \sqrt{(P^2 + Q^2 + 2PQ \times \cos 180^\circ)} = \sqrt{(P^2 + Q^2 - 2PQ)} = \sqrt{(P-Q)^2} = P-Q$$

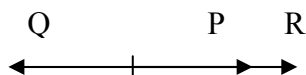

Case-III: If $\alpha = 90^\circ$

$$R = \sqrt{(P^2 + Q^2 + 2PQ \times \cos 90^\circ)} = \sqrt{P^2 + Q^2}$$

$$\alpha = \tan^{-1} (Q/P)$$

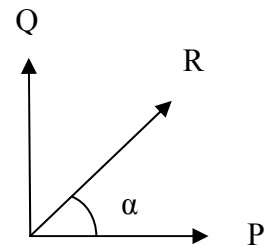

Resolution of a force

The replacement of a single force by a several components which will be equivalent in action to the given force is called resolution of a force.

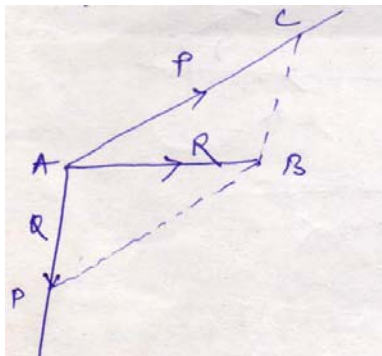

Action and reaction

Often bodies in equilibrium are constrained to investigate the conditions.

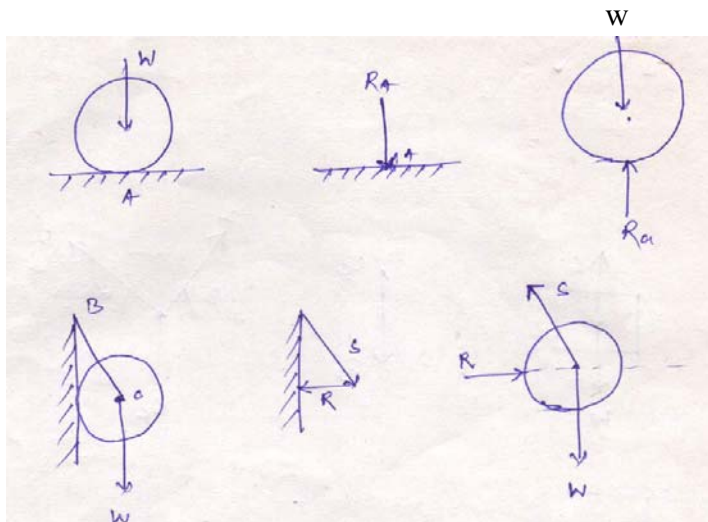

Free body diagram

Free body diagram is necessary to investigate the condition of equilibrium of a body or system. While drawing the free body diagram all the supports of the body are removed and replaced with the reaction forces acting on it.

1. Draw the free body diagrams of the following figures.

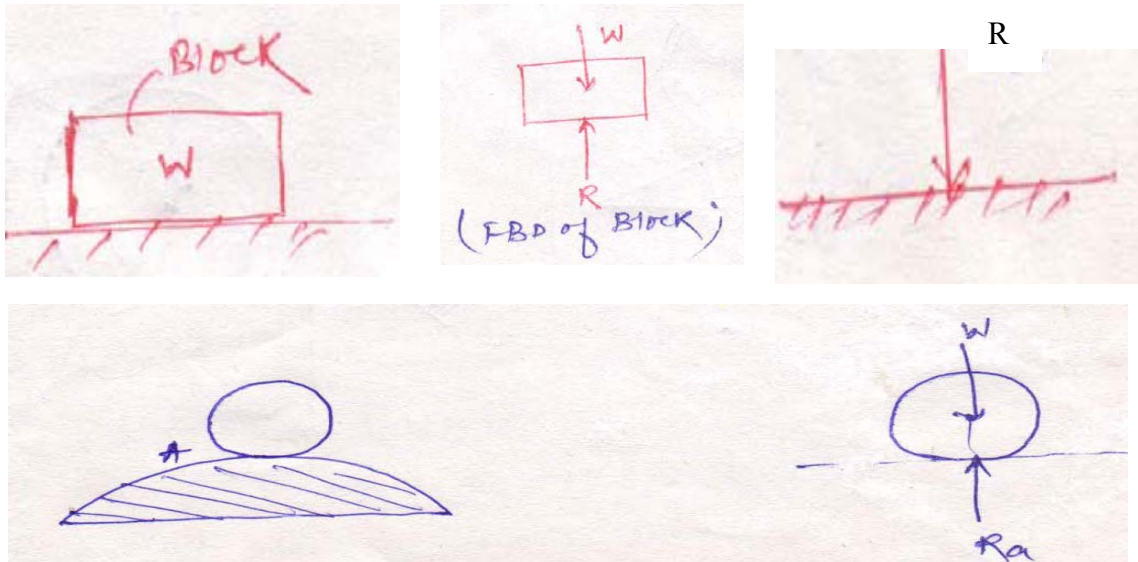

2. Draw the free body diagram of the body, the string CD and the ring.

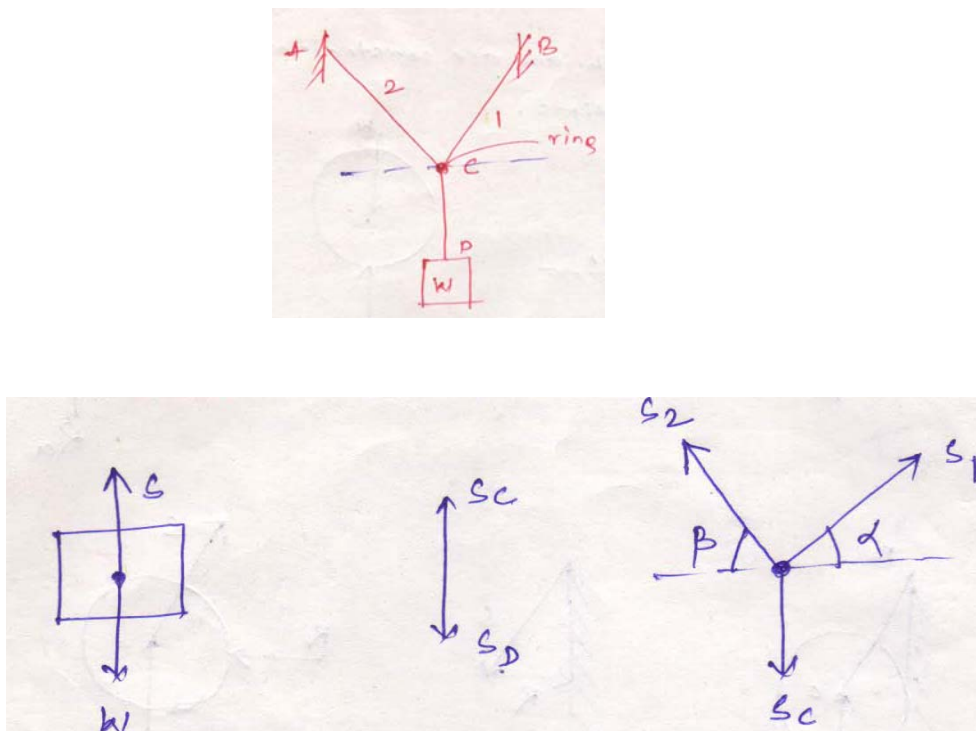

3. Draw the free body diagram of the following figures.

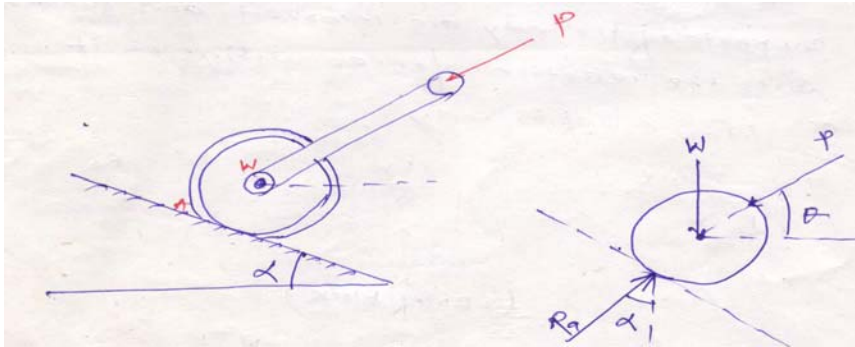
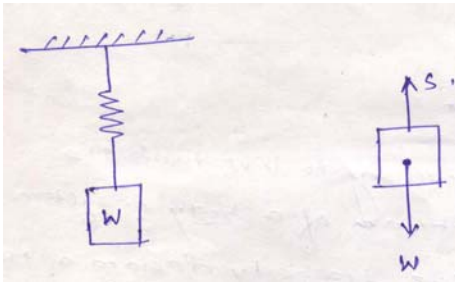

Equilibrium of colinear forces:

Equilibrium law: Two forces can be in equilibrium only if they are equal in magnitude, opposite in direction and collinear in action.

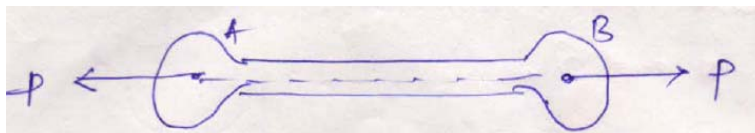

(tension)

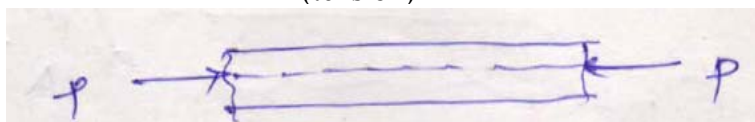

(compression)

Superposition and transmissibility

Problem 1: A man of weight $W = 712 \text{ N}$ holds one end of a rope that passes over a pulley vertically above his head and to the other end of which is attached a weight $Q = 534 \text{ N}$. Find the force with which the man's feet press against the floor.

Tension in the string S is equal to the load attached to it

$Q = 534 \text{ N}$.

So $S = 534 \text{ N}$.

Now applying parallelogram law resultant force

$$R = \sqrt{W^2 + S^2 + 2WS \cos 180^\circ}$$

$$= \sqrt{W^2 + S^2 - 2WS}$$

$$= \sqrt{(W - S)^2} = W - S$$

$\Rightarrow R = 712 - 534 = 178 \text{ N}$ (\downarrow)

Reaction on the man's feet $= 178 \text{ N}$ (\uparrow)

Problem 2: A boat is moved uniformly along a canal by two horses pulling with forces $P = 890 \text{ N}$ and $Q = 1068 \text{ N}$ acting under an angle $\alpha = 60^\circ$. Determine the magnitude of the resultant pull on the boat and the angles β and ν .

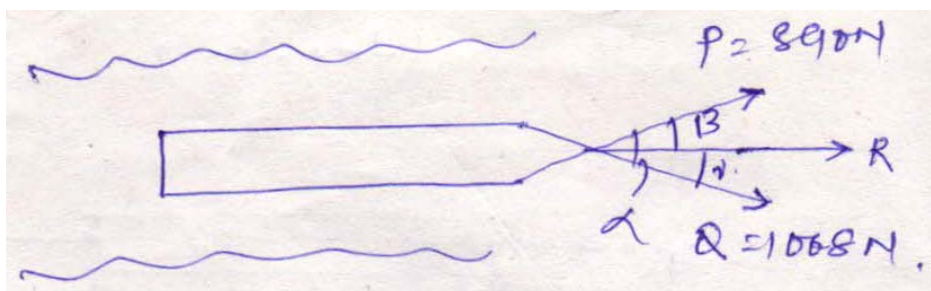

$P = 890 \text{ N}, \alpha = 60^\circ$

$Q = 1068 \text{ N}$

$$R = \sqrt{P^2 + Q^2 + 2PQ \cos \alpha}$$

$$= \sqrt{(890^2 + 1068^2 + 2 \times 890 \times 1068 \times 0.5)}$$

$= 1698.01 \text{ N}$

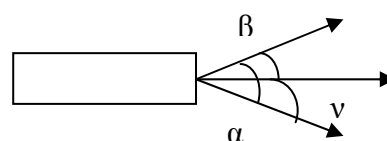

$$\frac{Q}{\sin \beta} = \frac{P}{\sin \nu} = \frac{R}{\sin(\pi - \alpha)}$$

$$\sin \beta = \frac{Q \sin \alpha}{R}$$

$$= \frac{1068 \times \sin 60^\circ}{1698.01}$$

$$= 33^\circ$$

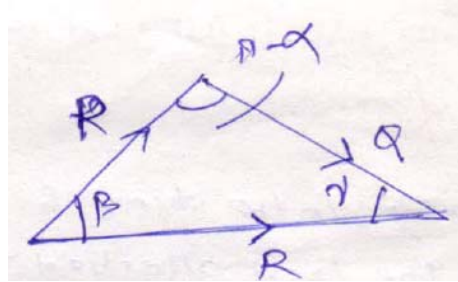

$$\sin \nu = \frac{P \sin \alpha}{R}$$

$$= \frac{890 \times \sin 60^\circ}{1698.01}$$

$$= 27^\circ$$

Resolution of a force

Replacement of a single force by several components which will be equivalent in action to the given force is called the problem of resolution of a force.

By using parallelogram law, a single force R can be resolved into two components P and Q intersecting at a point on its line of action.

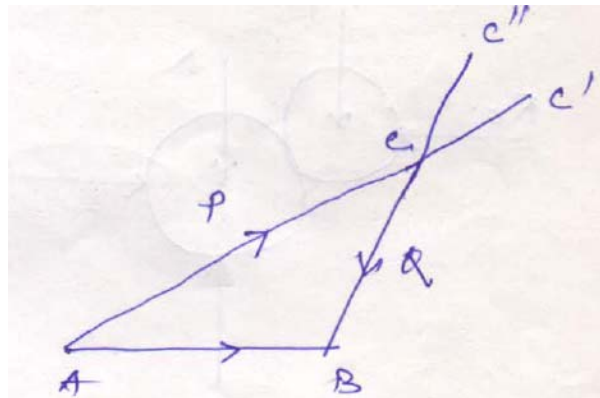
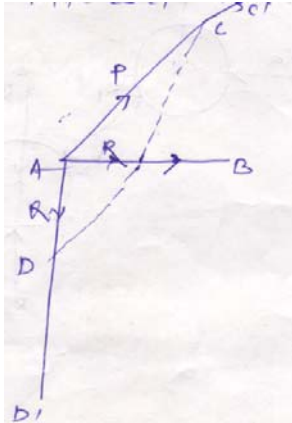

Equilibrium of collinear forces:

Equilibrium law: Two forces can be in equilibrium only if they are equal in magnitude, opposite in direction and collinear in action.



Law of superposition

The action of a given system of forces on a rigid body will no way be changed if we add to or subtract from them another system of forces in equilibrium.

Problem 3: Two spheres of weight P and Q rest inside a hollow cylinder which is resting on a horizontal force. Draw the free body diagram of both the spheres, together and separately.

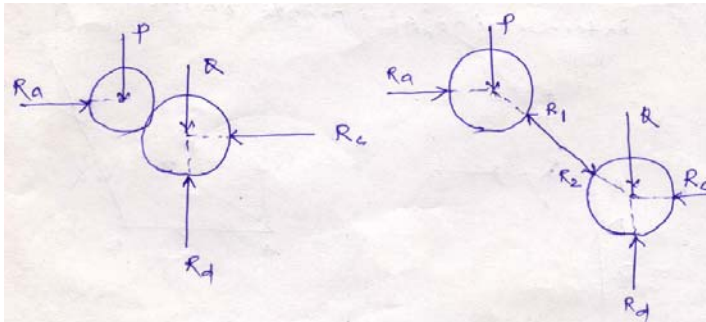
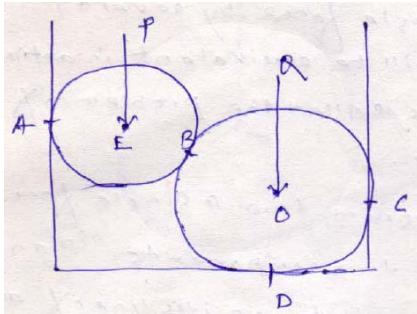

Problem 4: Draw the free body diagram of the figure shown below.

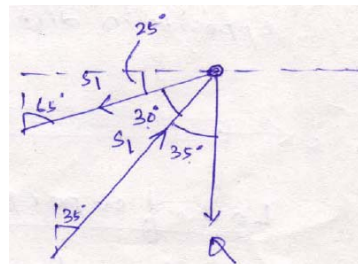
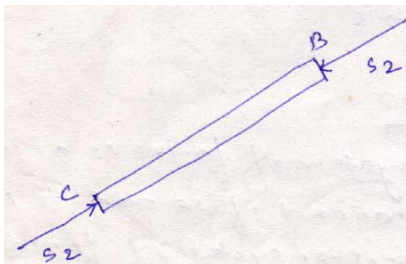
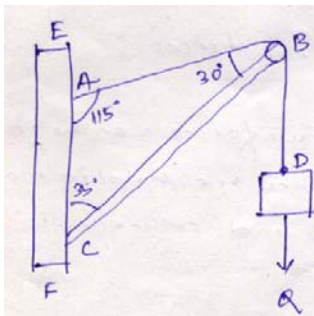

Problem 5: Determine the angles α and β shown in the figure.

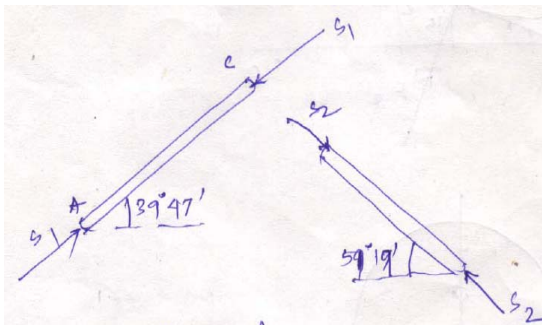
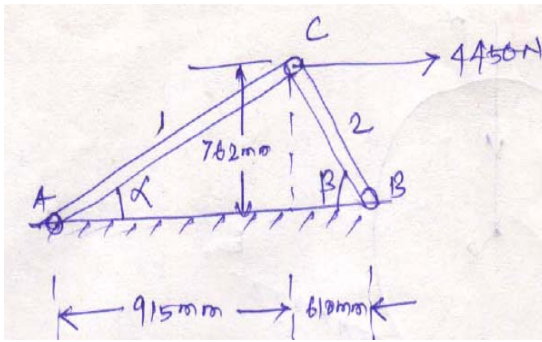

$$\alpha = \tan^{-1}\left(\frac{762}{915}\right)$$

$$= 39^{\circ}47'$$

$$\beta = \tan^{-1}\left(\frac{762}{610}\right)$$

$$= 51^{\circ}19'$$

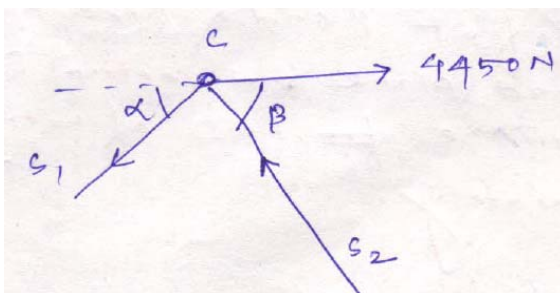

Problem 6: Find the reactions R_1 and R_2 .

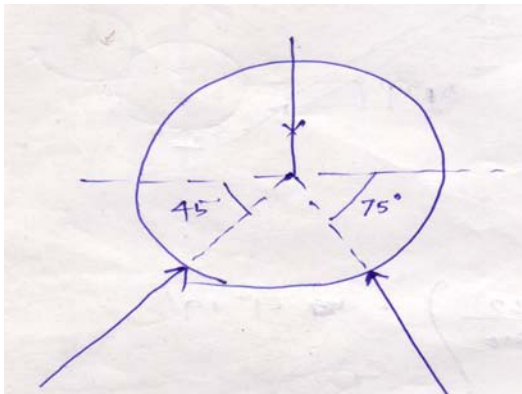
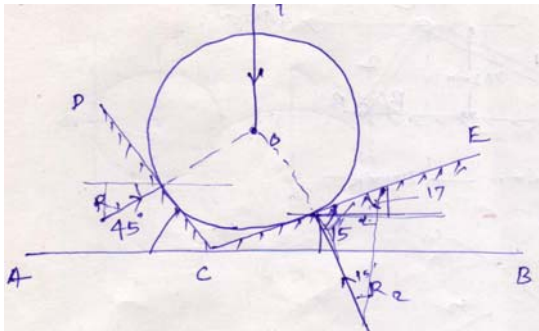

Problem 7: Two rollers of weight P and Q are supported by an inclined plane and vertical walls as shown in the figure. Draw the free body diagram of both the rollers separately.

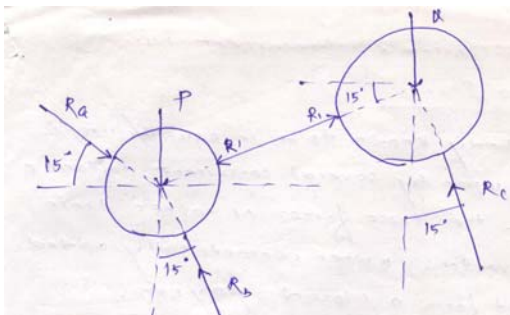
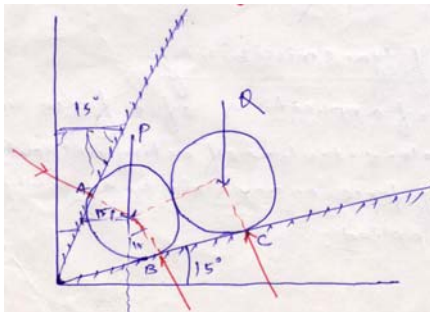

Problem 8: Find θ_n and θ_t in the following figure.

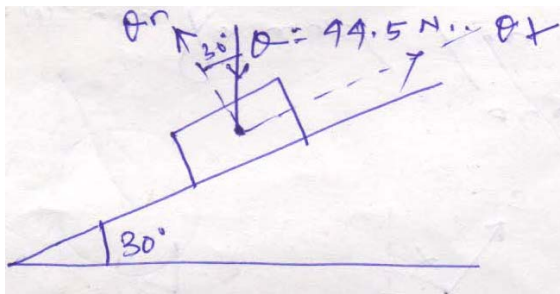

Problem 9: For the particular position shown in the figure, the connecting rod BA of an engine exert a force of $P = 2225 \text{ N}$ on the crank pin at A. Resolve this force into two rectangular components P_h and P_v horizontally and vertically respectively at A.

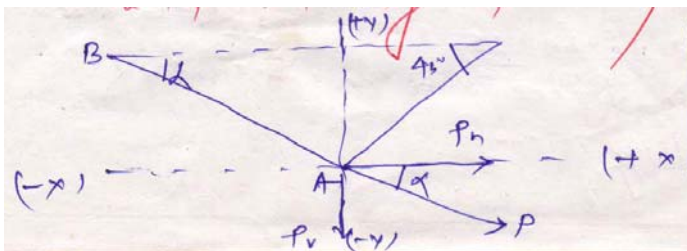

$P_h = 2081.4 \text{ N}$

$P_v = 786.5 \text{ N}$

Equilibrium of concurrent forces in a plane

- If a body known to be in equilibrium is acted upon by several concurrent, coplanar forces, then these forces or rather their free vectors, when geometrically added must form a closed polygon.
- This system represents the condition of equilibrium for any system of concurrent forces in a plane.

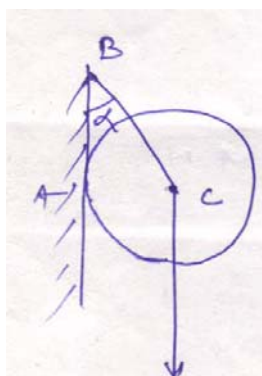

w

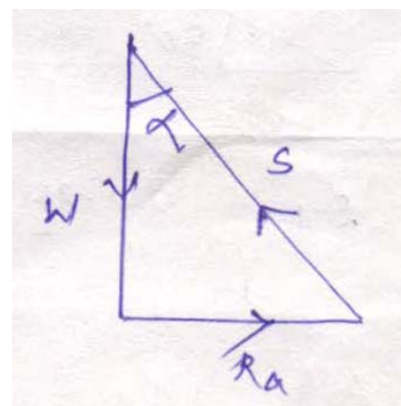
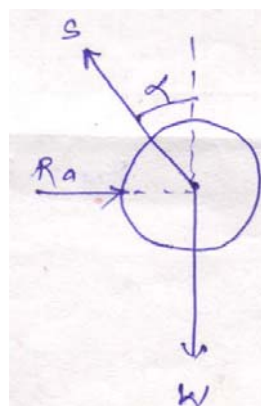

$$R_a = w \tan \alpha$$

$$S = w \sec \alpha$$

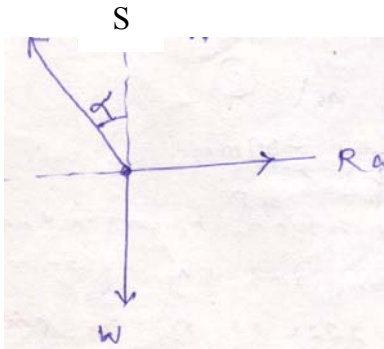

Lami's theorem

If three concurrent forces are acting on a body kept in an equilibrium, then each force is proportional to the sine of angle between the other two forces and the constant of proportionality is same.

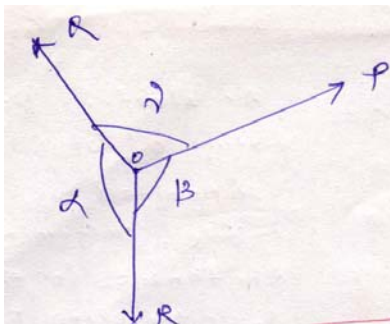

$$\frac{P}{\sin \alpha} = \frac{Q}{\sin \beta} = \frac{R}{\sin \nu}$$

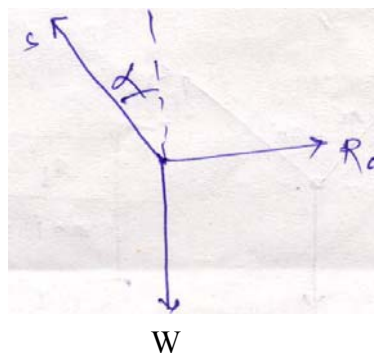
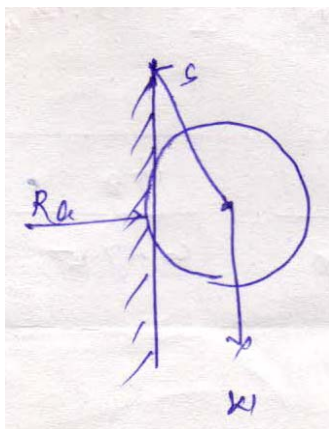

$$\frac{S}{\sin 90} = \frac{R_a}{\sin(180 - \alpha)} = \frac{W}{\sin(90 + \alpha)}$$

Problem: A ball of weight $Q = 53.4\text{N}$ rest in a right angled trough as shown in figure. Determine the forces exerted on the sides of the trough at D and E if all the surfaces are perfectly smooth.

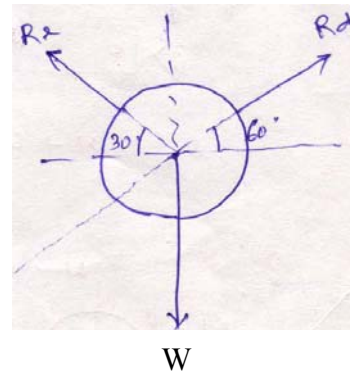
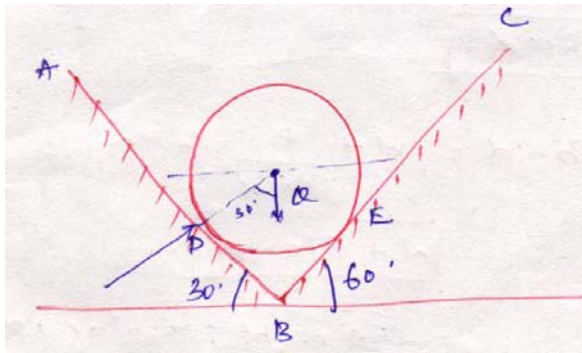

Problem: An electric light fixture of weight $Q = 178\text{ N}$ is supported as shown in figure. Determine the tensile forces S_1 and S_2 in the wires BA and BC, if their angles of inclination are given.

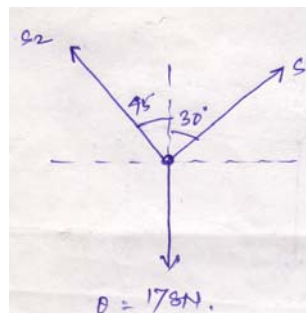
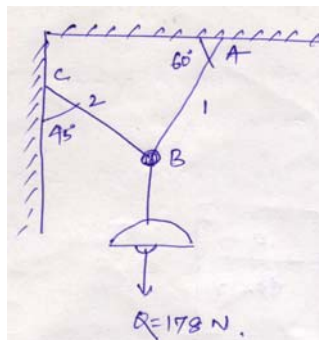

$$\frac{S_1}{\sin 135} = \frac{S_2}{\sin 150} = \frac{178}{\sin 75}$$

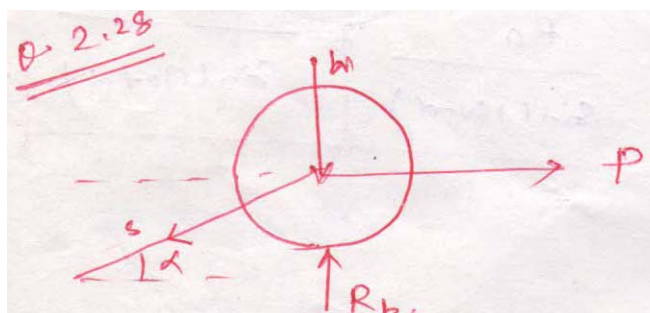

$$S_1 \cos \alpha = P$$

$$S = P \sec \alpha$$

$$\begin{aligned}
 R_b &= W + S \sin \alpha \\
 &= W + \frac{P}{\cos \alpha} \times \sin \alpha \\
 &= W + P \tan \alpha
 \end{aligned}$$

Problem: A right circular roller of weight W rests on a smooth horizontal plane and is held in position by an inclined bar AC . Find the tensions in the bar AC and vertical reaction R_b if there is also a horizontal force P is active.

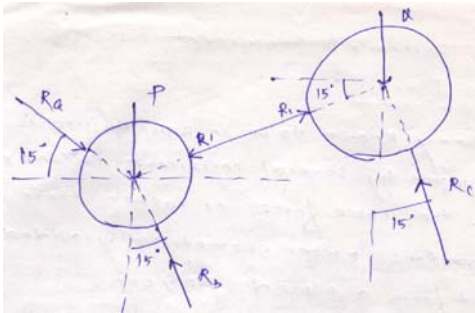

Theory of transmissibility of a force:

The point of application of a force may be transmitted along its line of action without changing the effect of force on any rigid body to which it may be applied.

Problem:

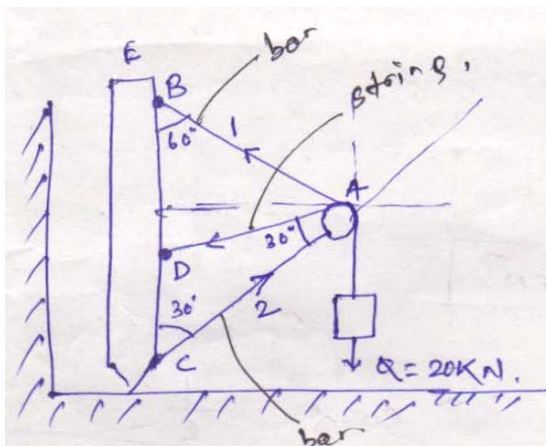

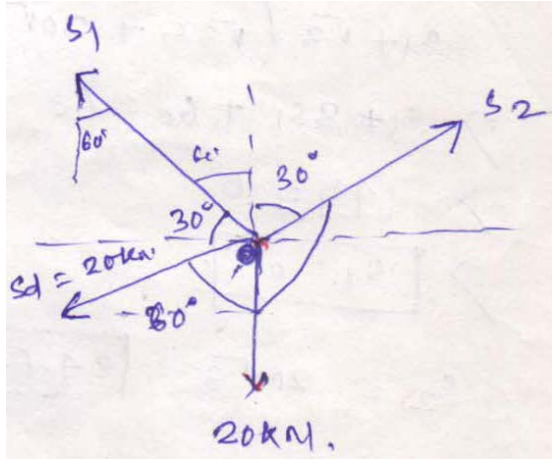

$$\sum X = 0$$

$$S_1 \cos 30 + 20 \sin 60 = S_2 \sin 30$$

$$\frac{\sqrt{3}}{2} S_1 + 20 \frac{\sqrt{3}}{2} = \frac{S_2}{2}$$

$$\frac{S_2}{2} = \frac{\sqrt{3}}{2} S_1 + 10\sqrt{3}$$

$$S_2 = \sqrt{3} S_1 + 20\sqrt{3}$$

(1)

$$\sum Y = 0$$

$$S_1 \sin 30 + S_2 \cos 30 = S_d \cos 60 + 20$$

$$\frac{S_1}{2} + S_2 \frac{\sqrt{3}}{2} = \frac{20}{2} + 20$$

$$\frac{S_1}{2} + \frac{\sqrt{3}}{2} S_2 = 30$$

$$S_1 + \sqrt{3} S_2 = 60$$

(2)

Substituting the value of S_2 in Eq.2, we get

$$S_1 + \sqrt{3} (\sqrt{3} S_1 + 20\sqrt{3}) = 60$$

$$S_1 + 3S_1 + 60 = 60$$

$$4S_1 = 0$$

$$S_1 = 0 \text{ KN}$$

$$S_2 = 20\sqrt{3} = 34.64 \text{ KN}$$

Problem: A ball of weight W is suspended from a string of length l and is pulled by a horizontal force Q . The weight is displaced by a distance d from the vertical position as shown in Figure. Determine the angle α , forces Q and tension in the string S in the displaced position.

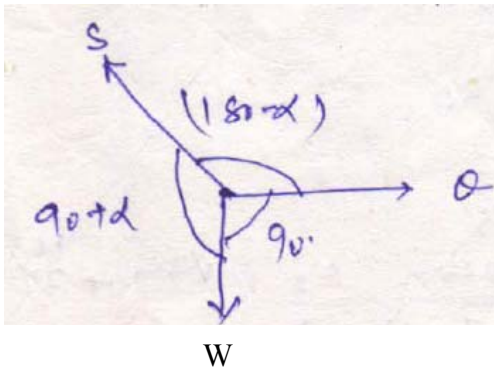
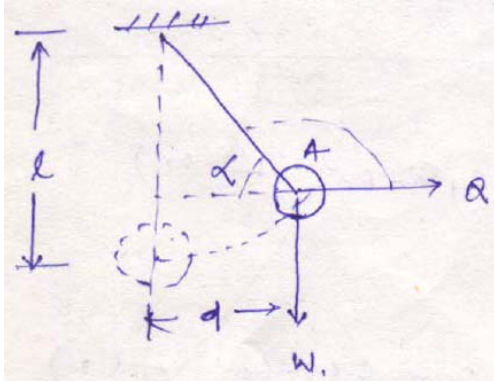

$$\cos \alpha = \frac{d}{l}$$

$$\alpha = \cos^{-1}\left(\frac{d}{l}\right)$$

$$\sin^2 \alpha + \cos^2 \alpha = 1$$

$$\Rightarrow \sin \alpha = \sqrt{1 - \cos^2 \alpha}$$

$$= \sqrt{1 - \frac{d^2}{l^2}}$$

$$= \frac{1}{l} \sqrt{l^2 - d^2}$$

Applying Lami's theorem,

$$\frac{S}{\sin 90} = \frac{Q}{\sin(90 + \alpha)} = \frac{W}{\sin(180 - \alpha)}$$

$$\frac{Q}{\sin(90 + \alpha)} = \frac{W}{\sin(180 - \alpha)}$$

$$\Rightarrow Q = \frac{W \cos \alpha}{\sin \alpha} = \frac{W \left(\frac{d}{l}\right)}{\frac{1}{l} \sqrt{l^2 - d^2}}$$

$$\Rightarrow Q = \frac{Wd}{\sqrt{l^2 - d^2}}$$

$$S = \frac{W}{\sin \alpha} = \frac{W}{\frac{1}{l} \sqrt{l^2 - d^2}}$$

$$= \frac{Wl}{\sqrt{l^2 - d^2}}$$

Problem: Two smooth circular cylinders each of weight $W = 445 \text{ N}$ and radius $r = 152 \text{ mm}$ are connected at their centres by a string AB of length $l = 406 \text{ mm}$ and rest upon a horizontal plane, supporting above them a third cylinder of weight $Q = 890 \text{ N}$ and radius $r = 152 \text{ mm}$. Find the forces in the string and the pressures produced on the floor at the point of contact.

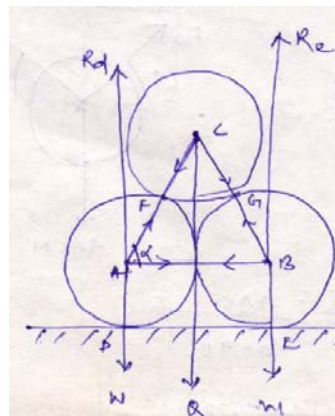
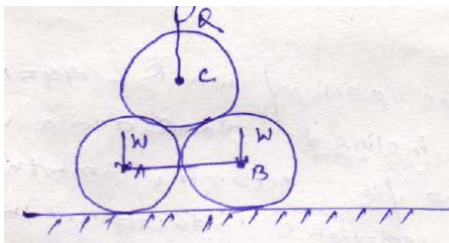

$$\cos \alpha = \frac{203}{304}$$

$$\Rightarrow \alpha = 48.1^\circ$$

$$\frac{R_g}{\sin 138.1} = \frac{R_e}{\sin 138.1} = \frac{Q}{83.8}$$

$$\Rightarrow R_g = R_e = 597.86 \text{ N}$$

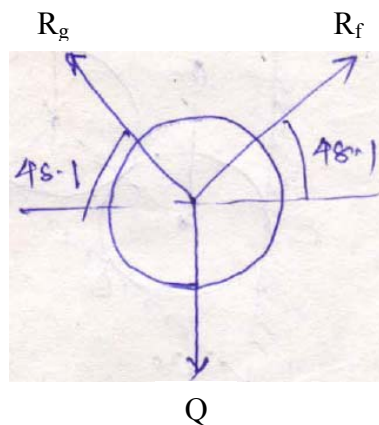

Resolving horizontally

$$\sum X = 0$$

$$S = R_f \cos 48.1$$

$$= 597.86 \cos 48.1$$

$$= 399.27 N$$

Resolving vertically

$$\sum Y = 0$$

$$R_d = W + R_f \sin 48.1$$

$$= 445 + 597.86 \sin 48.1$$

$$= 890 N$$

$$R_e = 890 N$$

$$S = 399.27 N$$

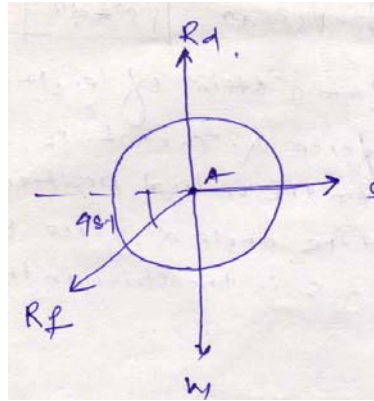

Problem: Two identical rollers each of weight $Q = 445 N$ are supported by an inclined plane and a vertical wall as shown in the figure. Assuming smooth surfaces, find the reactions induced at the points of support A, B and C.

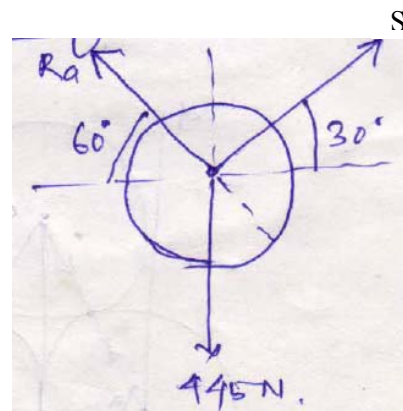
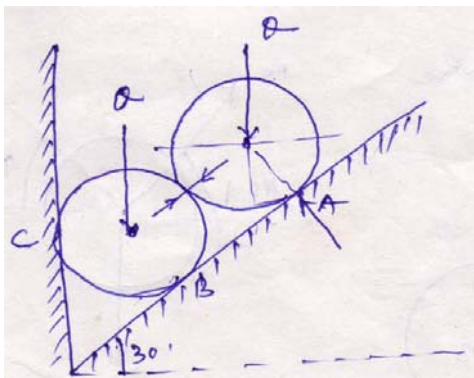

$$\frac{R_a}{\sin 120} = \frac{S}{\sin 150} = \frac{445}{\sin 90}$$

$$\Rightarrow R_a = 385.38 N$$

$$\Rightarrow S = 222.5 N$$

Resolving vertically

$$\sum Y = 0$$

$$R_b \cos 60 = 445 + S \sin 30$$

$$\Rightarrow R_b \frac{\sqrt{3}}{2} = 445 + \frac{222.5}{2}$$

$$\Rightarrow R_b = 642.302 N$$

Resolving horizontally

$$\sum X = 0$$

$$R_c = R_b \sin 30 + S \cos 30$$

$$\Rightarrow 642.302 \sin 30 + 222.5 \cos 30$$

$$\Rightarrow R_c = 513.84 N$$

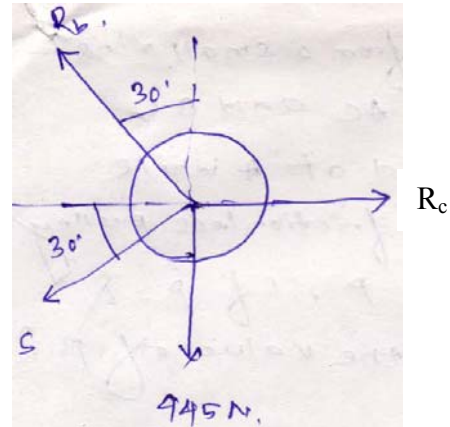

Problem:

A weight Q is suspended from a small ring C supported by two cords AC and BC . The cord AC is fastened at A while cord BC passes over a frictionless pulley at B and carries a weight P . If $P = Q$ and $\alpha = 50^\circ$, find the value of β .

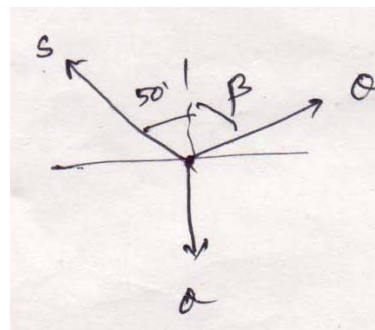
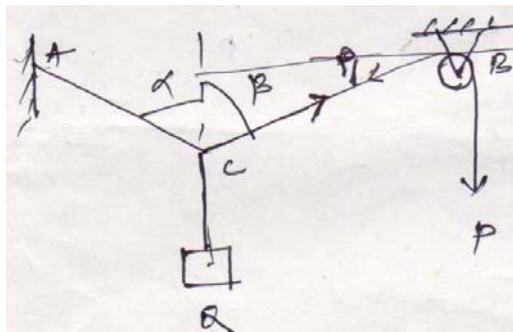

Resolving horizontally

$$\sum X = 0$$

$$S \sin 50 = Q \sin \beta$$

(1)

Resolving vertically

$$\sum Y = 0$$

$$S \cos 50 + Q \sin \beta = Q$$

$$\Rightarrow S \cos 50 = Q(1 - \cos \beta)$$

Putting the value of S from Eq. 1, we get

$$S \cos 50 + Q \sin \beta = Q$$

$$\Rightarrow S \cos 50 = Q(1 - \cos \beta)$$

$$\Rightarrow Q \frac{\sin \beta}{\sin 50} \cos 50 = Q(1 - \cos \beta)$$

$$\Rightarrow \cot 50 = \frac{1 - \cos \beta}{\sin \beta}$$

$$\Rightarrow 0.839 \sin \beta = 1 - \cos \beta$$

Squaring both sides,

$$0.703 \sin^2 \beta = 1 + \cos^2 \beta - 2 \cos \beta$$

$$0.703(1 - \cos^2 \beta) = 1 + \cos^2 \beta - 2 \cos \beta$$

$$0.703 - 0.703 \cos^2 \beta = 1 + \cos^2 \beta - 2 \cos \beta$$

$$\Rightarrow 1.703 \cos^2 \beta - 2 \cos \beta + 0.297 = 0$$

$$\Rightarrow \cos^2 \beta - 1.174 \cos \beta + 0.297 = 0$$

$$\Rightarrow \beta = 63.13^\circ$$

Method of moments

Moment of a force with respect to a point:

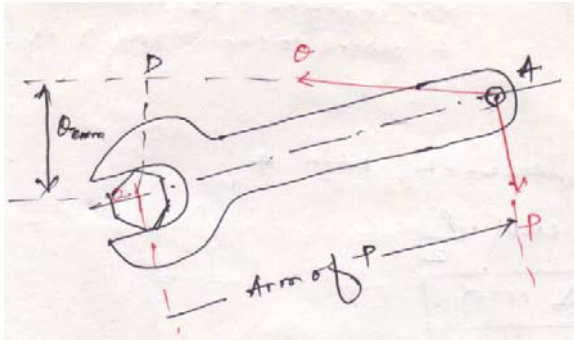

- Considering wrench subjected to two forces P and Q of equal magnitude. It is evident that force P will be more effective compared to Q, though they are of equal magnitude.
- The effectiveness of the force as regards its tendency to produce rotation of a body about a fixed point is called the moment of the force with respect to that point.
- Moment = Magnitude of the force \times Perpendicular distance of the line of action of force.
- Point O is called moment centre and the perpendicular distance (i.e. OD) is called moment arm.
- Unit is N.m

Theorem of Varignon:

The moment of the resultant of two concurrent forces with respect to a centre in their plane is equal to the algebraic sum of the moments of the components with respect to some centre.

Problem 1:

A prismatic bar of AB of length l is hinged at A and supported at B. Neglecting friction, determine the reaction R_b produced at B owing to the weight Q of the bar.

Taking moment about point A,

$$R_b \times l = Q \cos \alpha \cdot \frac{l}{2}$$

$$\Rightarrow R_b = \frac{Q}{2} \cos \alpha$$

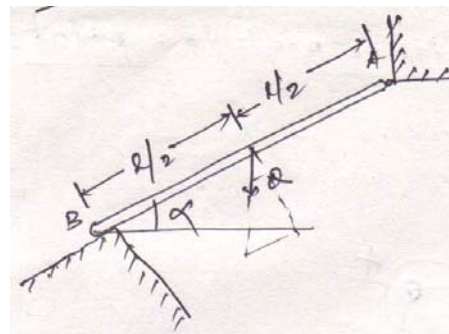

Problem 2:

A bar AB of weight Q and length $2l$ rests on a very small frictionless roller at D and against a smooth vertical wall at A . Find the angle α that the bar must make with the horizontal in equilibrium.

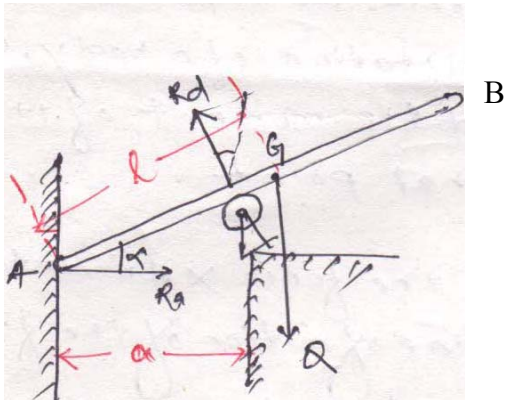

Resolving vertically,
 $R_d \cos \alpha = Q$

Now taking moment about A,

$$\begin{aligned} \frac{R_d \cdot a}{\cos \alpha} - Ql \cos \alpha &= 0 \\ \Rightarrow \frac{Q \cdot a}{\cos^2 \alpha} - Ql \cos \alpha &= 0 \\ \Rightarrow Q \cdot a - Ql \cos^3 \alpha &= 0 \\ \Rightarrow \cos^3 \alpha &= \frac{Q \cdot a}{Ql} \\ \Rightarrow \alpha &= \cos^{-1} \sqrt[3]{\frac{a}{l}} \end{aligned}$$

Problem 3:

If the piston of the engine has a diameter of 101.6 mm and the gas pressure in the cylinder is 0.69 MPa. Calculate the turning moment M exerted on the crankshaft for the particular configuration.

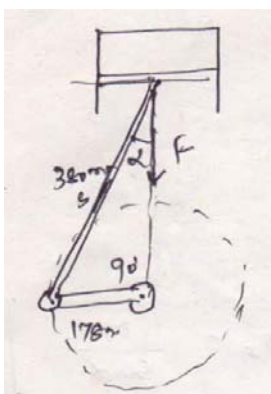

Area of cylinder

$$A = \frac{\pi}{4}(0.1016)^2 = 8.107 \times 10^{-3} m^2$$

Force exerted on connecting rod,

$$\begin{aligned} F &= \text{Pressure} \times \text{Area} \\ &= 0.69 \times 10^6 \times 8.107 \times 10^{-3} \\ &= 5593.83 \text{ N} \end{aligned}$$

$$\text{Now } \alpha = \sin^{-1}\left(\frac{178}{380}\right) = 27.93^\circ$$

$$S \cos \alpha = F$$

$$\Rightarrow S = \frac{F}{\cos \alpha} = 6331.29 \text{ N}$$

Now moment entered on crankshaft,

$$S \cos \alpha \times 0.178 = 995.7 \text{ N} = 1 \text{ KN}$$

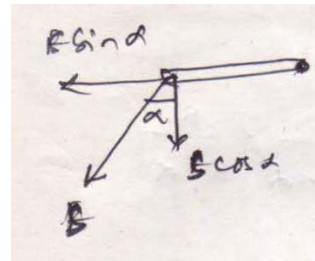

Problem 4:

A rigid bar AB is supported in a vertical plane and carrying a load Q at its free end. Neglecting the weight of bar, find the magnitude of tensile force S in the horizontal string CD.

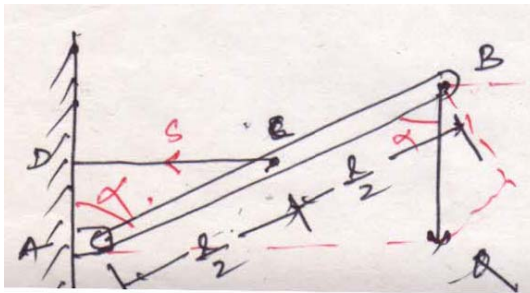

Taking moment about A,

$$\sum M_A = 0$$

$$S \cdot \frac{l}{2} \cos \alpha = Q \cdot l \sin \alpha$$

$$\Rightarrow S = \frac{Q \cdot l \sin \alpha}{\frac{l}{2} \cos \alpha}$$

$$\Rightarrow S = 2Q \cdot \tan \alpha$$

Friction

- The force which opposes the movement or the tendency of movement is called **Frictional force or simply friction**. It is due to the resistance to motion offered by minutely projecting particles at the contact surfaces. However, there is a limit beyond which the magnitude of this force cannot increase.
- If the applied force is more than this limit, there will be movement of one body over the other. This limiting value of frictional force when the motion is impending, it is known as **Limiting Friction**.
- When the applied force is less than the limiting friction, the body remains at rest and such frictional force is called **Static Friction**, which will be having any value between zero and the limiting friction.
- If the value of applied force exceeds the limiting friction, the body starts moving over the other body and the frictional resistance experienced by the body while moving is known as **Dynamic Friction**. Dynamic friction is less than limiting friction.
- Dynamic friction is classified into following two types:
 - a) Sliding friction
 - b) Rolling friction
- Sliding friction is the friction experienced by a body when it slides over the other body.
- Rolling friction is the friction experienced by a body when it rolls over a surface.
- It is experimentally found that the magnitude of limiting friction bears a constant ratio to the normal reaction between two surfaces and this ratio is called **Coefficient of Friction**.

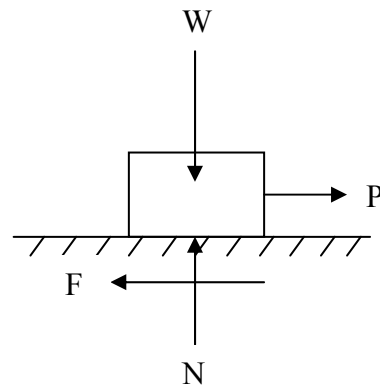

$$\text{Coefficient of friction} = \frac{F}{N}$$

where F is limiting friction and N is normal reaction between the contact surfaces.

Coefficient of friction is denoted by μ .

$$\text{Thus, } \mu = \frac{F}{N}$$

Laws of friction

1. The force of friction always acts in a direction opposite to that in which body tends to move.
2. Till the limiting value is reached, the magnitude of friction is exactly equal to the force which tends to move the body.
3. The magnitude of the limiting friction bears a constant ratio to the normal reaction between the two surfaces of contact and this ratio is called coefficient of friction.
4. The force of friction depends upon the roughness/smoothness of the surfaces.
5. The force of friction is independent of the area of contact between the two surfaces.
6. After the body starts moving, the dynamic friction comes into play, the magnitude of which is less than that of limiting friction and it bears a constant ratio with normal force. This ratio is called **coefficient of dynamic friction**.

Angle of friction

Consider the block shown in figure resting on a horizontal surface and subjected to horizontal pull P. Let F be the frictional force developed and N the normal reaction. Thus, at contact surface the reactions are F and N. They can be graphically combined to get the reaction R which acts at angle θ to normal reaction. This angle θ called the angle of friction is given by

$$\tan \theta = \frac{F}{N}$$

As P increases, F increases and hence θ also increases. θ can reach the maximum value α when F reaches limiting value. At this stage,

$$\tan \alpha = \frac{F}{N} = \mu$$

This value of α is called Angle of Limiting Friction. Hence, the angle of limiting friction may be defined as the angle between the resultant reaction and the normal to the plane on which the motion of the body is impending.

Angle of repose

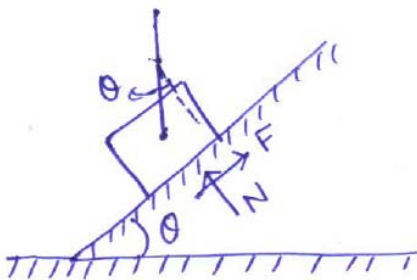

Consider the block of weight W resting on an inclined plane which makes an angle θ with the horizontal. When θ is small, the block will rest on the plane. If θ is gradually increased, a stage is reached at which the block start sliding down the plane. The angle θ for which the motion is impending, is called the angle of repose. Thus, the maximum inclination of the plane on which a body, free from external forces, can repose is called **Angle of Repose**.

Resolving vertically,

$$N = W \cdot \cos \theta$$

Resolving horizontally,

$$F = W \cdot \sin \theta$$

$$\text{Thus, } \tan \theta = \frac{F}{N}$$

If ϕ is the value of θ when the motion is impending, the frictional force will be limiting friction and hence,

$$\tan \phi = \frac{F}{N}$$

$$= \mu = \tan \alpha$$

$$\Rightarrow \phi = \alpha$$

Thus, the value of angle of repose is same as the value of limiting angle of repose.

Cone of friction

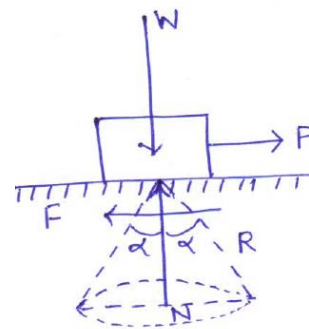

- When a body is having impending motion in the direction of force P , the frictional force will be limiting friction and the resultant reaction R will make limiting angle α with the normal.
- If the body is having impending motion in some other direction, the resultant reaction makes limiting frictional angle α with the normal to that direction. Thus, when the direction of force P is gradually changed through 360° , the resultant R generates a right circular cone with semi-central angle equal to α .

Problem 1: Block A weighing 1000N rests over block B which weighs 2000N as shown in figure. Block A is tied to wall with a horizontal string. If the coefficient of friction between blocks A and B is 0.25 and between B and floor is 1/3, what should be the value of P to move the block (B), if

- (a) P is horizontal.
- (b) P acts at 30° upwards to horizontal.

Solution: (a)

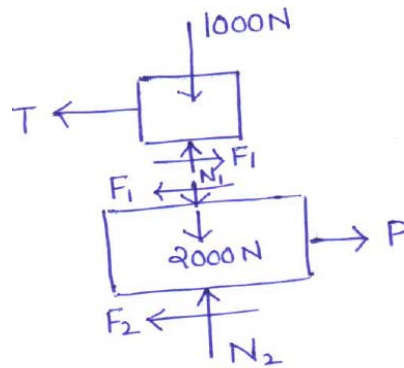
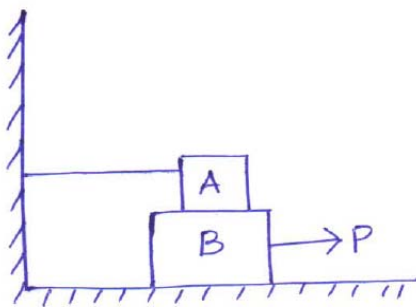

Considering block A,

$$\sum V = 0$$

$$N_1 = 1000N$$

Since F_1 is limiting friction,

$$\frac{F_1}{N_1} = \mu = 0.25$$

$$F_1 = 0.25N_1 = 0.25 \times 1000 = 250N$$

$$\sum H = 0$$

$$F_1 - T = 0$$

$$T = F_1 = 250N$$

Considering equilibrium of block B,

$$\sum V = 0$$

$$N_2 - 2000 - N_1 = 0$$

$$N_2 = 2000 + N_1 = 2000 + 1000 = 3000N$$

$$\frac{F_2}{N_2} = \mu = \frac{1}{3}$$

$$F_2 = 0.3N_2 = 0.3 \times 3000 = 1000N$$

$$\sum H = 0$$

$$P = F_1 + F_2 = 250 + 1000 = 1250N$$

(b) When P is inclined:

$$\sum V = 0$$

$$N_2 - 2000 - N_1 + P \cdot \sin 30 = 0$$

$$\Rightarrow N_2 + 0.5P = 2000 + 1000$$

$$\Rightarrow N_2 = 3000 - 0.5P$$

From law of friction,

$$F_2 = \frac{1}{3}N_2 = \frac{1}{3}(3000 - 0.5P) = 1000 - \frac{0.5}{3}P$$

$$\sum H = 0$$

$$P \cos 30 = F_1 + F_2$$

$$\Rightarrow P \cos 30 = 250 + \left(1000 - \frac{0.5}{3}P\right)$$

$$\Rightarrow P \left(\cos 30 + \frac{0.5}{3}\right) = 1250$$

$$\Rightarrow P = 1210.43N$$

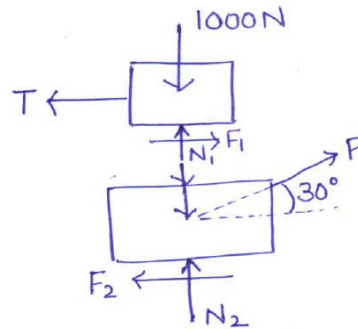

Problem 2: A block weighing 500N just starts moving down a rough inclined plane when supported by a force of 200N acting parallel to the plane in upward direction. The same block is on the verge of moving up the plane when pulled by a force of 300N acting parallel to the plane. Find the inclination of the plane and coefficient of friction between the inclined plane and the block.

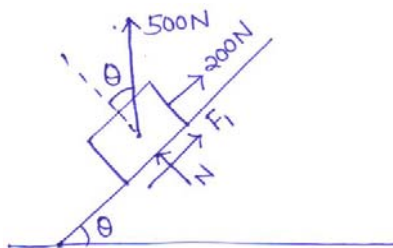

$$\sum V = 0$$

$$N = 500 \cdot \cos \theta$$

$$F_1 = \mu N = \mu \cdot 500 \cos \theta$$

$$\begin{aligned}\sum H &= 0 \\ 200 + F_1 &= 500 \cdot \sin \theta \\ \Rightarrow 200 + \mu \cdot 500 \cos \theta &= 500 \cdot \sin \theta\end{aligned}\tag{1}$$

$$\begin{aligned}\sum V &= 0 \\ N &= 500 \cdot \cos \theta \\ F_2 &= \mu N = \mu \cdot 500 \cdot \cos \theta\end{aligned}$$

$$\begin{aligned}\sum H &= 0 \\ 500 \sin \theta + F_2 &= 300 \\ \Rightarrow 500 \sin \theta + \mu \cdot 500 \cos \theta &= 300\end{aligned}\tag{2}$$

Adding Eqs. (1) and (2), we get

$$\begin{aligned}500 &= 1000 \cdot \sin \theta \\ \sin \theta &= 0.5 \\ \theta &= 30^\circ\end{aligned}$$

Substituting the value of θ in Eq. 2,

$$500 \sin 30 + \mu \cdot 500 \cos 30 = 300$$

$$\mu = \frac{50}{500 \cos 30} = 0.11547$$

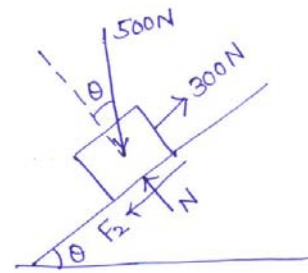

Parallel forces on a plane

Like parallel forces: Coplanar parallel forces when act in the same direction.



Unlike parallel forces: Coplanar parallel forces when act in different direction.



Resultant of like parallel forces:

Let P and Q are two like parallel forces act at points A and B.

$$R = P + Q$$

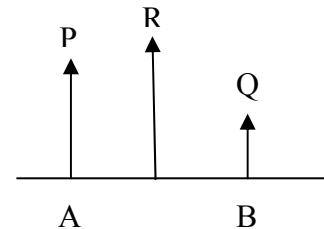

Resultant of unlike parallel forces:

$$R = P - Q$$

R is in the direction of the force having greater magnitude.

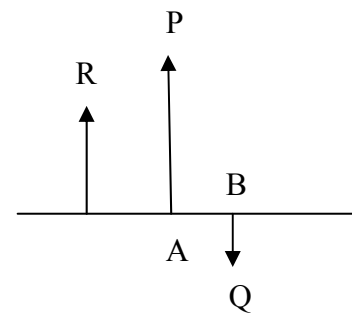

Couple:

Two unlike equal parallel forces form a couple.

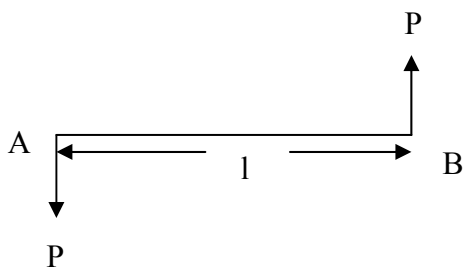

The rotational effect of a couple is measured by its moment.

$$\text{Moment} = P \times l$$

Sign convention: Anticlockwise couple (Positive)
 Clockwise couple (Negative)

Problem 1 : A rigid bar CABD supported as shown in figure is acted upon by two equal horizontal forces P applied at C and D. Calculate the reactions that will be induced at the points of support. Assume $l = 1.2$ m, $a = 0.9$ m, $b = 0.6$ m.

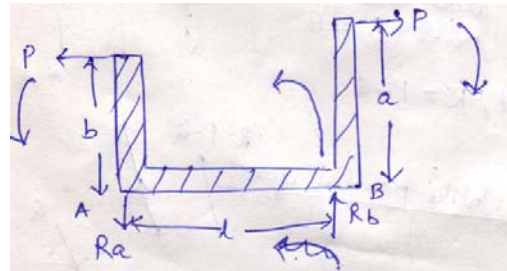
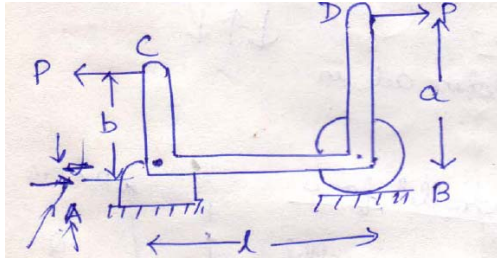

$$\sum V = 0$$

$$R_a = R_b$$

Taking moment about A,

$$R_a = R_b$$

$$R_b \times l + P \times b = P \times a$$

$$\Rightarrow R_b = \frac{P(0.9 - 0.6)}{1.2}$$

$$\Rightarrow R_b = 0.25P(\uparrow)$$

$$\Rightarrow R_a = 0.25P(\downarrow)$$

Problem 2: Owing to weight W of the locomotive shown in figure, the reactions at the two points of support A and B will each be equal to $W/2$. When the locomotive is pulling the train and the drawbar pull P is just equal to the total friction at the points of contact A and B, determine the magnitudes of the vertical reactions R_a and R_b .

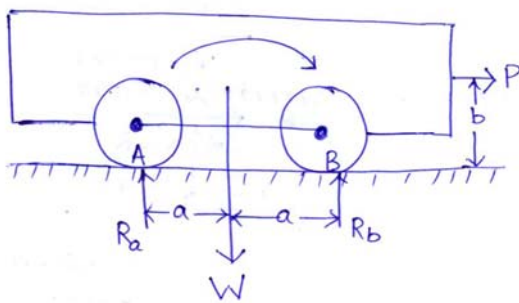

$$\sum V = 0$$

$$R_a + R_b = W$$

Taking moment about B,

$$\begin{aligned} \sum M_B &= 0 \\ R_a \times 2a + P \times b &= W \times a \\ \Rightarrow R_a &= \frac{W \cdot a - P \cdot b}{2a} \\ \therefore R_b &= W - R_a \\ \Rightarrow R_b &= W - \left(\frac{W \cdot a - P \cdot b}{2a} \right) \\ \Rightarrow R_b &= \frac{W \cdot a + P \cdot b}{2a} \end{aligned}$$

Problem 3: The four wheels of a locomotive produce vertical forces on the horizontal girder AB. Determine the reactions R_a and R_b at the supports if the loads $P = 90$ KN each and $Q = 72$ KN (All dimensions are in m).

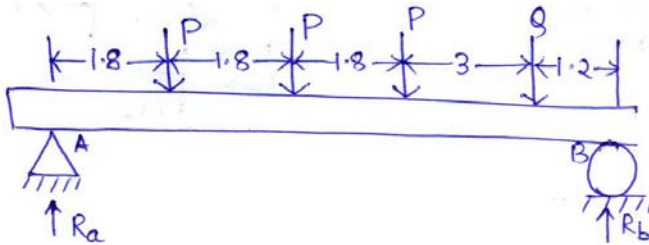

$$\begin{aligned} \sum V &= 0 \\ R_a + R_b &= 3P + Q \\ \Rightarrow R_a + R_b &= 3 \times 90 + 72 \\ \Rightarrow R_a + R_b &= 342 \text{ KN} \\ \sum M_A &= 0 \\ R_b \times 9.6 &= 90 \times 1.8 + 90 \times 3.6 + 90 \times 5.4 + 72 \times 8.4 \\ \Rightarrow R_b &= 164.25 \text{ KN} \\ \therefore R_a &= 177.75 \text{ KN} \end{aligned}$$

Problem 4: The beam AB in figure is hinged at A and supported at B by a vertical cord which passes over a frictionless pulley at C and carries at its end a load P. Determine the distance x from A at which a load Q must be placed on the beam if it is to remain in equilibrium in a horizontal position. Neglect the weight of the beam.

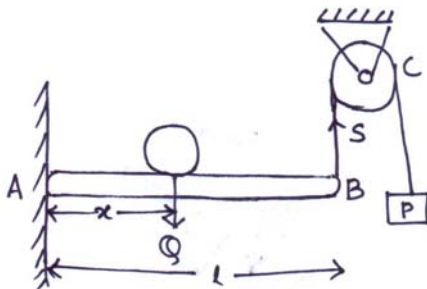

FBD

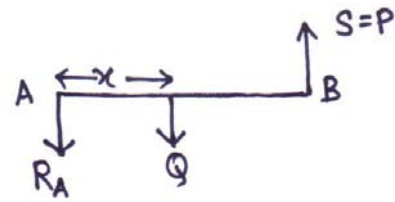
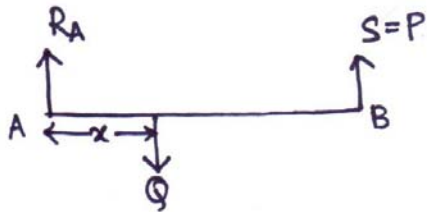

$$\sum M_A = 0$$

$$S \times l = Q \times x$$

$$\Rightarrow x = \frac{P \cdot l}{Q}$$

Problem 5: A prismatic bar AB of weight $Q = 44.5 \text{ N}$ is supported by two vertical wires at its ends and carries at D a load $P = 89 \text{ N}$ as shown in figure. Determine the forces S_a and S_b in the two wires.

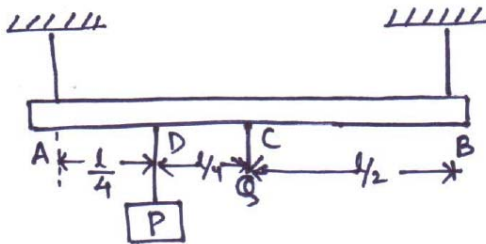

$$Q = 44.5 \text{ N}$$

$$P = 89 \text{ N}$$

Resolving vertically,

$$\sum V = 0$$

$$S_a + S_b = P + Q$$

$$\Rightarrow S_a + S_b = 89 + 44.5$$

$$\Rightarrow S_a + S_b = 133.5 \text{ N}$$

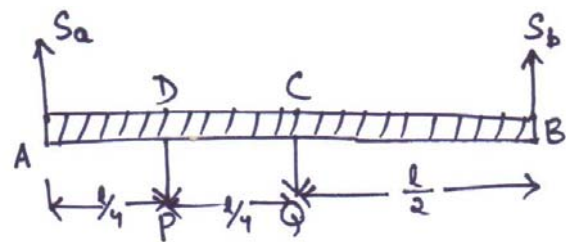

$$\begin{aligned} \sum M_A &= 0 \\ S_b \times l &= P \times \frac{l}{4} + Q \times \frac{l}{2} \\ \Rightarrow S_b &= \frac{P}{4} + \frac{Q}{2} \\ \Rightarrow S_b &= \frac{89}{4} + \frac{44.5}{2} \\ \Rightarrow S_b &= 44.5 \\ \therefore S_a &= 133.5 - 44.5 \\ \Rightarrow S_a &= 89N \end{aligned}$$

Centre of gravity

Centre of gravity: It is that point through which the resultant of the distributed gravity force passes regardless of the orientation of the body in space.

- As the point through which resultant of force of gravity (weight) of the body acts.

Centroid: Centroid of an area lies on the axis of symmetry if it exists.

Centre of gravity is applied to bodies with mass and weight and centroid is applied to plane areas.

$$\begin{aligned} x_c &= \sum A_i x_i \\ y_c &= \sum A_i y_i \end{aligned}$$

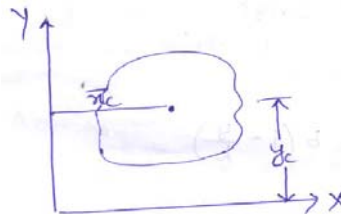

$$\begin{aligned} x_c &= \frac{A_1 x_1 + A_2 x_2}{A_1 + A_2} \\ y_c &= \frac{A_1 y_1 + A_2 y_2}{A_1 + A_2} \end{aligned}$$

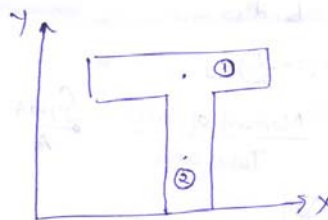

$$x_c = y_c = \frac{\text{Moment of area}}{\text{Total area}}$$

$$x_c = \frac{\int x.dA}{A}$$

$$y_c = \frac{\int y.dA}{A}$$

Problem 1: Consider the triangle ABC of base 'b' and height 'h'. Determine the distance of centroid from the base.

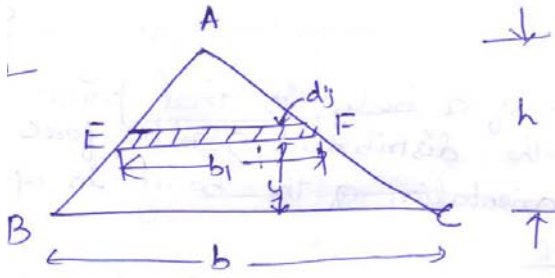

Let us consider an elemental strip of width 'b₁' and thickness 'dy'.

$$\triangle AEF \sim \triangle ABC$$

$$\therefore \frac{b_1}{b} = \frac{h-y}{h}$$

$$\Rightarrow b_1 = b \left(\frac{h-y}{h} \right)$$

$$\Rightarrow b_1 = b \left(1 - \frac{y}{h} \right)$$

$$\begin{aligned} \text{Area of element EF (dA)} &= b_1 \times dy \\ &= b \left(1 - \frac{y}{h} \right) dy \end{aligned}$$

$$\begin{aligned} y_c &= \frac{\int y \cdot dA}{A} \\ &= \frac{\int_0^h y b \left(1 - \frac{y}{h} \right) dy}{\frac{1}{2} b \cdot h} \\ &= \frac{b \left[\frac{y^2}{2} - \frac{y^3}{3h} \right]_0^h}{\frac{1}{2} b \cdot h} \\ &= \frac{2}{h} \left[\frac{h^2}{2} - \frac{h^3}{3} \right] \\ &= \frac{2}{h} \times \frac{h^2}{6} \\ &= \frac{h}{3} \end{aligned}$$

Therefore, y_c is at a distance of h/3 from base.

Problem 2: Consider a semi-circle of radius R. Determine its distance from diametral axis.

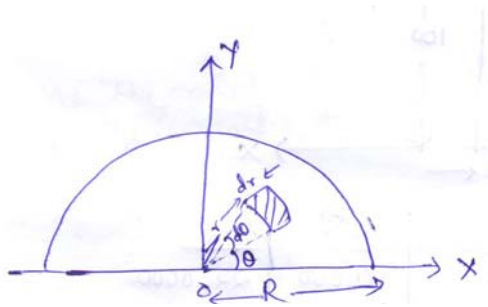

Due to symmetry, centroid 'y_c' must lie on Y-axis.

Consider an element at a distance 'r' from centre 'o' of the semicircle with radial width dr.

Area of element = (r.dθ)×dr

Moment of area about x = ∫ y.dA

$$= \int_0^{\pi} \int_0^R (r.d\theta).dr \times (r.\sin \theta)$$

$$= \int_0^{\pi} \int_0^R r^2 \sin \theta.dr.d\theta$$

$$= \int_0^{\pi} \left(\int_0^R r^2.dr \right). \sin \theta.d\theta$$

$$= \int_0^{\pi} \left[\frac{r^3}{3} \right]_0^R . \sin \theta.d\theta$$

$$= \int_0^{\pi} \frac{R^3}{3} . \sin \theta.d\theta$$

$$= \frac{R^3}{3} [-\cos \theta]_0^{\pi}$$

$$= \frac{R^3}{3} [1+1]$$

$$= \frac{2}{3} R^3$$

$$y_c = \frac{\text{Moment of area}}{\text{Total area}}$$

$$\begin{aligned}
 &= \frac{\frac{2}{3}R^3}{\frac{\pi R^2}{2}} \\
 &= \frac{4R}{3\pi}
 \end{aligned}$$

Therefore, the centroid of the semicircle is at a distance of $\frac{4R}{3\pi}$ from the diametric axis.

Centroids of different figures

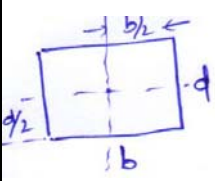
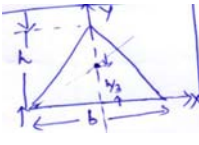
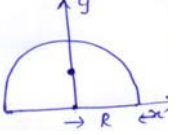
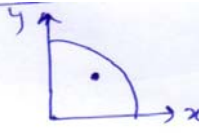
Shape	Figure	\bar{x}	\bar{y}	Area
Rectangle		$\frac{b}{2}$	$\frac{d}{2}$	bd
Triangle		0	$\frac{h}{3}$	$\frac{bh}{2}$
Semicircle		0	$\frac{4R}{3\pi}$	$\frac{\pi r^2}{2}$
Quarter circle		$\frac{4R}{3\pi}$	$\frac{4R}{3\pi}$	$\frac{\pi r^2}{4}$

Problem 3: Find the centroid of the T-section as shown in figure from the bottom.

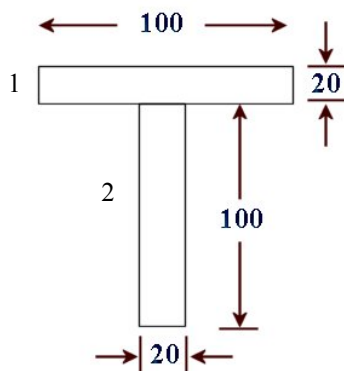

Area (A_i)	x_i	y_i	$A_i x_i$	$A_i y_i$
2000	0	110	10,000	22,0000
2000	0	50	10,000	10,0000
4000			20,000	32,0000

$$y_c = \frac{\sum A_i y_i}{A_i} = \frac{A_1 y_1 + A_2 y_2}{A_1 + A_2} = \frac{32,0000}{4000} = 80$$

Due to symmetry, the centroid lies on Y-axis and it is at distance of 80 mm from the bottom.

Problem 4: Locate the centroid of the I-section.

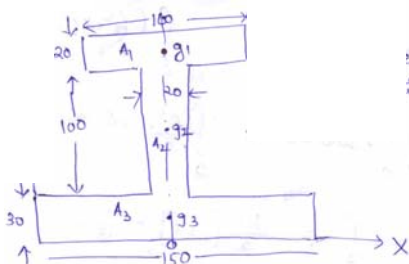

As the figure is symmetric, centroid lies on y-axis. Therefore, $\bar{x} = 0$

Area (A_i)	x_i	y_i	$A_i x_i$	$A_i y_i$
2000	0	140	0	280000
2000	0	80	0	160000
4500	0	15	0	67500

$$y_c = \frac{\sum A_i y_i}{A_i} = \frac{A_1 y_1 + A_2 y_2 + A_3 y_3}{A_1 + A_2 + A_3} = 59.71 \text{ mm}$$

Thus, the centroid is on the symmetric axis at a distance 59.71 mm from the bottom.

Problem 5: Determine the centroid of the composite figure about x-y coordinate. Take $x = 40$ mm.

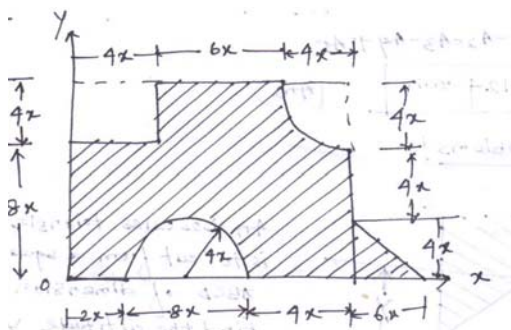

$$A_1 = \text{Area of rectangle} = 12x \cdot 14x = 168x^2$$

$$A_2 = \text{Area of rectangle to be subtracted} = 4x \cdot 4x = 16x^2$$

$$A_3 = \text{Area of semicircle to be subtracted} = \frac{\pi R^2}{2} = \frac{\pi(4x)^2}{2} = 25.13x^2$$

$$A_4 = \text{Area of quatercircle to be subtracted} = \frac{\pi R^2}{4} = \frac{\pi(4x)^2}{4} = 12.56x^2$$

$$A_5 = \text{Area of triangle} = \frac{1}{2} \times 6x \times 4x = 12x^2$$

Area (A _i)	x _i	y _i	A _i x _i	A _i y _i
A ₁ = 268800	7x = 280	6x = 240	75264000	64512000
A ₂ = 25600	2x = 80	10x = 400	2048000	10240000
A ₃ = 40208	6x = 240	$\frac{4 \times 4x}{3\pi} = 67.906$	9649920	2730364.448
A ₄ = 20096	$10x + \left(4x - \frac{4 \times 4x}{3\pi}\right)$ = 492.09	$8x + \left(4x - \frac{4 \times 4x}{3\pi}\right)$ = 412.093	9889040.64	8281420.926
A ₅ = 19200	$14x + \frac{6x}{3} = 16x$ = 640	$\frac{4x}{3} = 53.33$	12288000	1023936

$$x_c = \frac{A_1x_1 - A_2x_2 - A_3x_3 - A_4x_4 + A_5x_5}{A_1 - A_2 - A_3 - A_4 + A_5} = 326.404mm$$

$$y_c = \frac{A_1y_1 - A_2y_2 - A_3y_3 - A_4y_4 + A_5y_5}{A_1 - A_2 - A_3 - A_4 + A_5} = 219.124mm$$

Problem 6: Determine the centroid of the following figure.

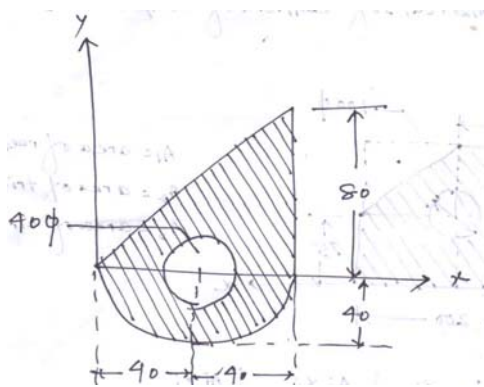

$$A_1 = \text{Area of triangle} = \frac{1}{2} \times 80 \times 80 = 3200m^2$$

$$A_2 = \text{Area of semicircle} = \frac{\pi d^2}{8} - \frac{\pi R^2}{2} = 2513.274m^2$$

$$A_3 = \text{Area of semicircle} = \frac{\pi D^2}{2} = 1256.64m^2$$

Area (A_i)	x_i	y_i	$A_i x_i$	$A_i y_i$
3200	$2 \times (80/3) = 53.33$	$80/3 = 26.67$	170656	85344
2513.274	40	$\frac{-4 \times 40}{3\pi} = -16.97$	100530.96	-42650.259
1256.64	40	0	50265.6	0

$$x_c = \frac{A_1 x_1 + A_2 x_2 - A_3 x_3}{A_1 + A_2 + A_3} = 49.57 \text{ mm}$$

$$y_c = \frac{A_1 y_1 + A_2 y_2 - A_3 y_3}{A_1 + A_2 - A_3} = 9.58 \text{ mm}$$

Problem 7: Determine the centroid of the following figure.

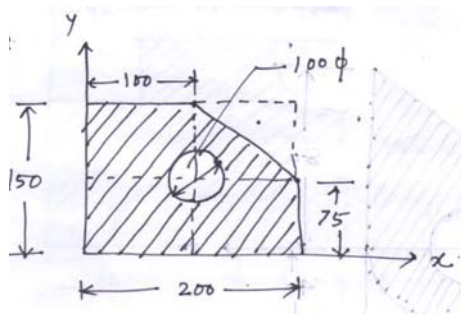

A_1 = Area of the rectangle

A_2 = Area of triangle

A_3 = Area of circle

Area (A_i)	x_i	y_i	$A_i x_i$	$A_i y_i$
30,000	100	75	3000000	2250000
3750	$100 + 200/3 = 166.67$	$75 + 150/3 = 125$	625012.5	468750
7853.98	100	75	785398	589048.5

$$x_c = \frac{\sum A_i x_i}{\sum A_i} = \frac{A_1 x_1 - A_2 x_2 - A_3 x_3}{A_1 - A_2 - A_3} = 86.4 \text{ mm}$$

$$y_c = \frac{\sum A_i y_i}{\sum A_i} = \frac{A_1 y_1 - A_2 y_2 - A_3 y_3}{A_1 - A_2 - A_3} = 64.8 \text{ mm}$$

Numerical Problems (Assignment)

1. An isosceles triangle ADE is to cut from a square ABCD of dimension 'a'. Find the altitude 'y' of the triangle so that vertex E will be centroid of remaining shaded area.

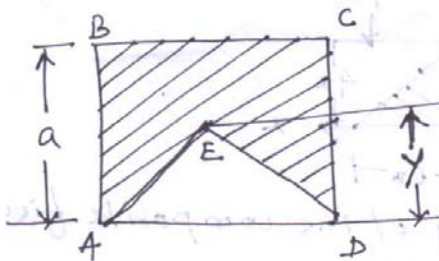

2. Find the centroid of the following figure.

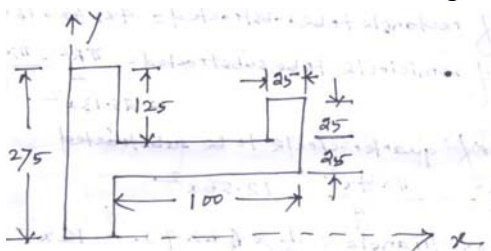

3. Locate the centroid C of the shaded area obtained by cutting a semi-circle of diameter 'a' from the quadrant of a circle of radius 'a'.

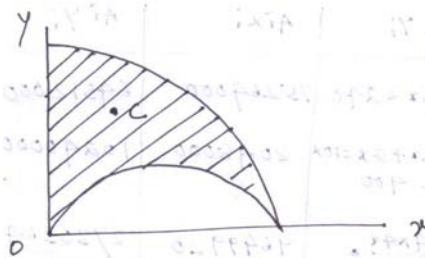

4. Locate the centroid of the composite figure.

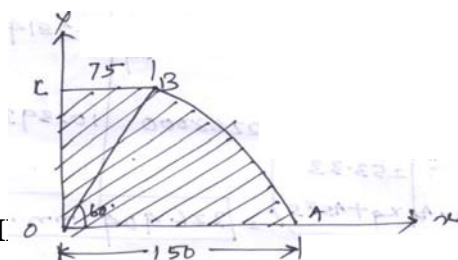

Module -I

Truss/ Frame: A pin jointed frame is a structure made of slender (cross-sectional dimensions quite small compared to length) members pin connected at ends and capable of taking load at joints.

Such frames are used as roof trusses to support sloping roofs and as bridge trusses to support deck.

Plane frame: A frame in which all members lie in a single plane is called plane frame. They are designed to resist the forces acting in the plane of frame. Roof trusses and bridge trusses are the example of plane frames.

Space frame: If all the members of frame do not lie in a single plane, they are called as space frame. Tripod, transmission towers are the examples of space frames.

Perfect frame: A pin jointed frame which has got just sufficient number of members to resist the loads without undergoing appreciable deformation in shape is called a perfect frame. Triangular frame is the simplest perfect frame and it has 03 joints and 03 members.

It may be observed that to increase one joint in a perfect frame, two more members are required. Hence, the following expression may be written as the relationship between number of joint j , and the number of members m in a perfect frame.

$$m = 2j - 3$$

- (a) When $LHS = RHS$, Perfect frame.
- (b) When $LHS < RHS$, Deficient frame.
- (c) When $LHS > RHS$, Redundant frame.

Assumptions

The following assumptions are made in the analysis of pin jointed trusses:

1. The ends of the members are pin jointed (hinged).
2. The loads act only at the joints.
3. Self weight of the members is negligible.

Methods of analysis

1. Method of joint
2. Method of section

Problems on method of joints

Problem 1: Find the forces in all the members of the truss shown in figure.

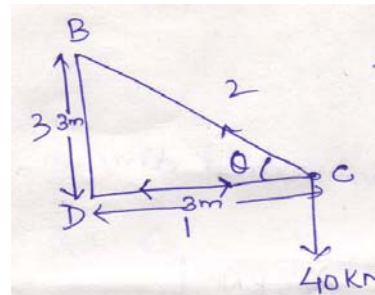
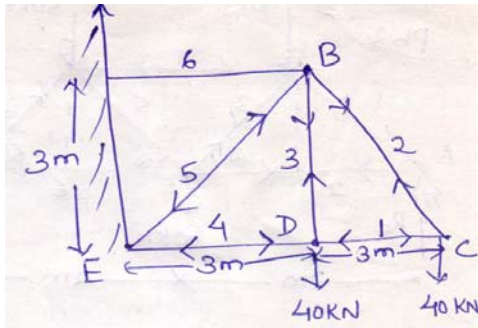
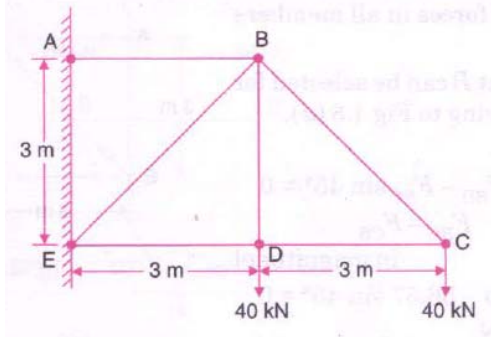

$\tan \theta = 1$
 $\Rightarrow \theta = 45^\circ$

Joint C

$S_1 = S_2 \cos 45$
 $\Rightarrow S_1 = 40 \text{ KN (Compression)}$
 $S_2 \sin 45 = 40$
 $\Rightarrow S_2 = 56.56 \text{ KN (Tension)}$

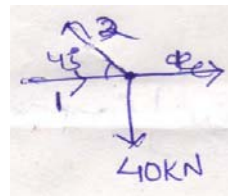

Joint D

$S_3 = 40 \text{ KN (Tension)}$
 $S_1 = S_4 = 40 \text{ KN (Compression)}$

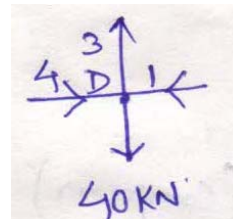

Joint B

Resolving vertically,
 $\sum V = 0$
 $S_5 \sin 45 = S_3 + S_2 \sin 45$

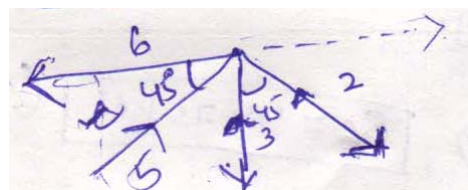

$$\Rightarrow S_5 = 113.137 \text{ KN (Compression)}$$

Resolving horizontally,

$$\sum H = 0$$

$$S_6 = S_5 \cos 45 + S_2 \cos 45$$

$$\Rightarrow S_6 = 113.137 \cos 45 + 56.56 \cos 45$$

$$\Rightarrow S_6 = 120 \text{ KN (Tension)}$$

Problem 2: Determine the forces in all the members of the truss shown in figure and indicate the magnitude and nature of the forces on the diagram of the truss. All inclined members are at 60° to horizontal and length of each member is 2m.

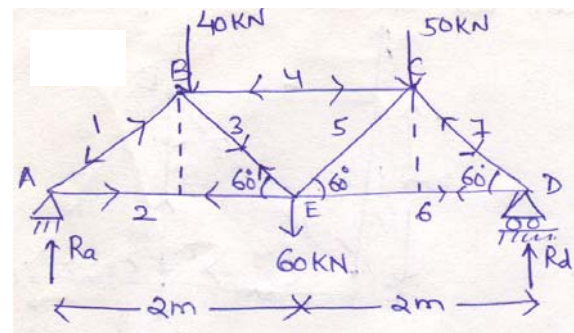
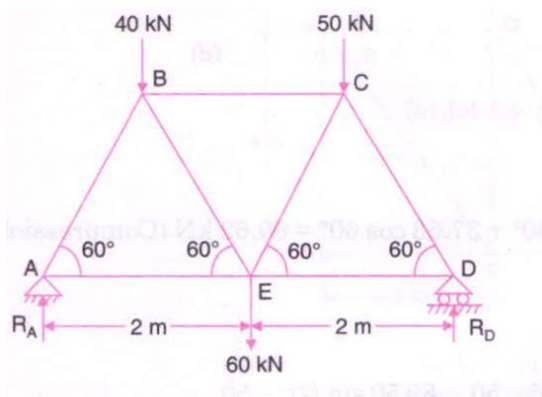

Taking moment at point A,

$$\sum M_A = 0$$

$$R_d \times 4 = 40 \times 1 + 60 \times 2 + 50 \times 3$$

$$\Rightarrow R_d = 77.5 \text{ KN}$$

Now resolving all the forces in vertical direction,

$$\sum V = 0$$

$$R_a + R_d = 40 + 60 + 50$$

$$\Rightarrow R_a = 72.5 \text{ KN}$$

Joint A

$$\sum V = 0$$

$$\Rightarrow R_a = S_1 \sin 60$$

$$\Rightarrow S_1 = 83.72 \text{ KN (Compression)}$$

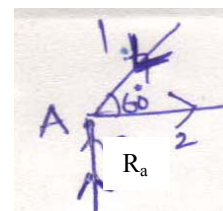

$$\sum H = 0$$

$$\Rightarrow S_2 = S_1 \cos 60$$

$$\Rightarrow S_1 = 41.86 \text{KN (Tension)}$$

Joint D

$$\sum V = 0$$

$$S_7 \sin 60 = 77.5$$

$$\Rightarrow S_7 = 89.5 \text{KN (Compression)}$$

$$\sum H = 0$$

$$S_6 = S_7 \cos 60$$

$$\Rightarrow S_6 = 44.75 \text{KN (Tension)}$$

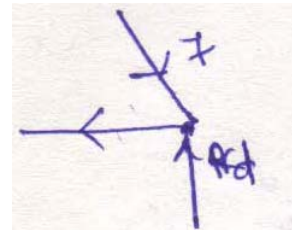

Joint B

$$\sum V = 0$$

$$S_1 \sin 60 = S_3 \cos 60 + 40$$

$$\Rightarrow S_3 = 37.532 \text{KN (Tension)}$$

$$\sum H = 0$$

$$S_4 = S_1 \cos 60 + S_3 \cos 60$$

$$\Rightarrow S_4 = 37.532 \cos 60 + 83.72 \cos 60$$

$$\Rightarrow S_4 = 60.626 \text{KN (Compression)}$$

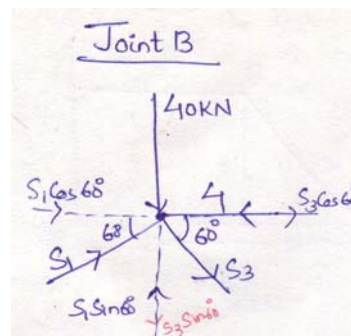

Joint C

$$\sum V = 0$$

$$S_5 \sin 60 + 50 = S_7 \sin 60$$

$$\Rightarrow S_5 = 31.76 \text{KN (Tension)}$$

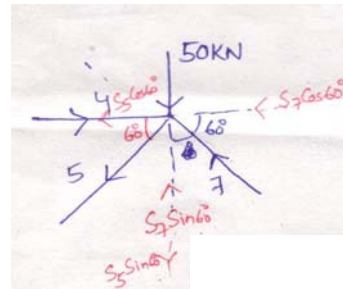

Plane Truss (Method of section)

<https://civinnovate.com/civil-engineering-notes/>

In case of analysing a plane truss, using method of section, after determining the support reactions a section line is drawn passing through not more than three members in which forces are unknown, such that the entire frame is cut into two separate parts.

~~Each~~ Each part should be in equilibrium under the action of loads, reactions and the forces in the members.

Method of section is preferred for the following cases:

(i) analysis of large truss in which forces in only few members are required

(ii) If method of joint fails to start or proceed with analysis for not getting a joint with only two unknown forces.

Example 1.

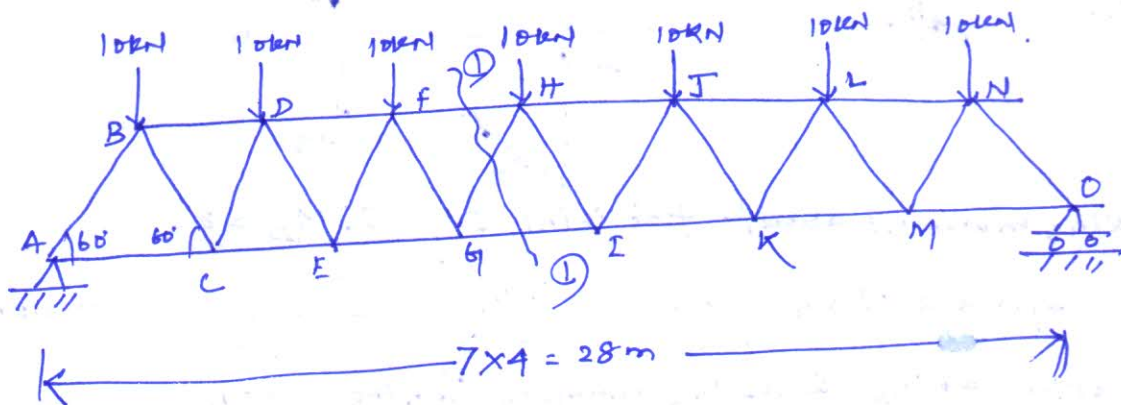

Determine the forces in the members FH, HG, and GL in the truss
 Due to symmetry $R_A = R_O = \frac{1}{2} \times \text{total downward load}$

$$= \frac{1}{2} \times 70 = \boxed{35 \text{ kN}}$$

Taking the section to the left of the cut.

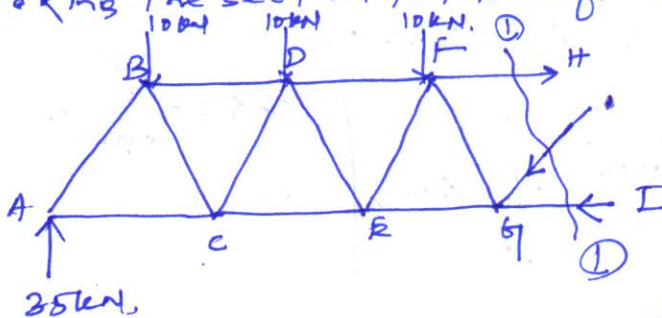

Taking moment about G

$$\sum M_G = 0$$

$$F_{FH} \times 4 \sin 60 + 35 \times 12$$

$$= 10 \times 2 + 10 \times 6 + 10 \times 10$$

$$\Rightarrow F_{FH} = \frac{(20 + 60 + 100) - 420}{4 \sin 60}$$

$$= -69.28 \text{ kN}$$

Negative sign indicates that direction should have opposite i.e. it's compressive in nature.

Now resolving all the forces vertically $\Sigma Y = 0$

$$10 + 10 + 10 + F_{GH} \sin 60 = 35$$

$$\Rightarrow F_{GH} = \frac{35 - 30}{\sin 60}$$

$$\Rightarrow \boxed{F_{GH} = 5.78 \text{ kN.}} \text{ (Compressive)}$$

Resolving all the forces horizontally $\Sigma X = 0$.

$$F_{FH} + F_{GH} \cos 60 = F_{GI}$$

$$\Rightarrow F_{GI} = 69.28 + 5.78 \cos 60 = \boxed{72.17 \text{ kN.}} \text{ (Tension)}$$

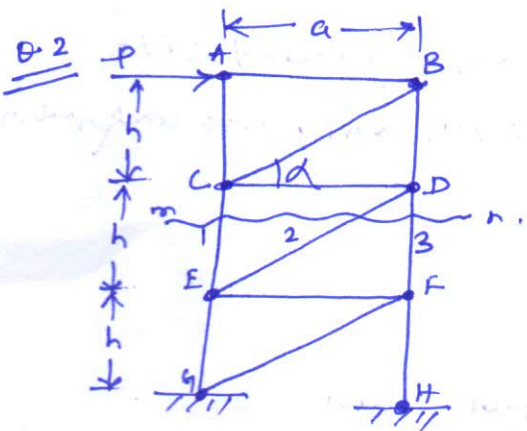

Using method of sections determine the axial forces in bars 1, 2 and 3.

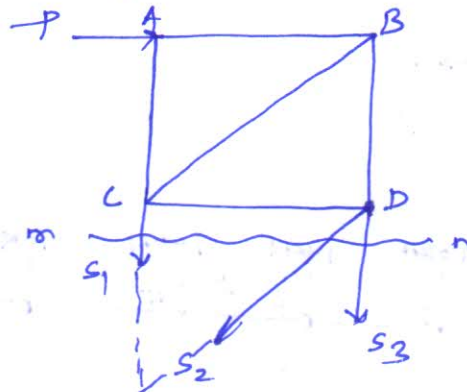

Taking moment about joint D $\Sigma M_D = 0$.

$$s_1 \times a = P \times h \Rightarrow \boxed{s_1 = \frac{Ph}{a}} \text{ --- (1) (Tension)}$$

Similarly taking E as the moment centre $\Sigma M_E = 0$

$$s_2 \times a + P \times 2h = 0$$

$$\Rightarrow \boxed{s_2 = \frac{-2Ph}{a}}$$

(-ve sign indicates direction of force will be opposite and it will be compressive in nature)

Resolving all the forces horizontally $\Sigma X = 0$.

$$s_2 \cos \alpha = P$$

$$\Rightarrow s_2 = \frac{P}{\cos \alpha} = \boxed{\frac{P \sqrt{a^2 + h^2}}{a}} \text{ (Ans.)}$$

$$\cos \alpha = \frac{a}{\sqrt{a^2 + h^2}}$$

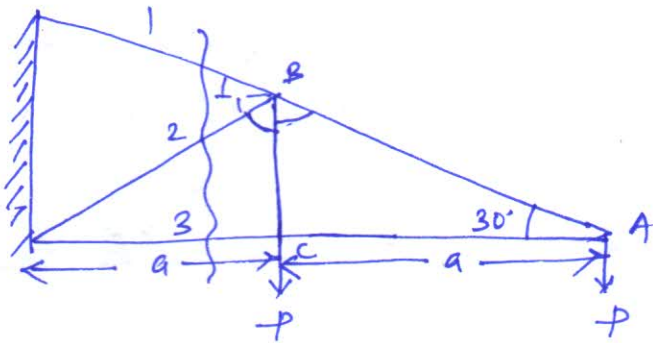

$$\frac{BC}{AC} = \tan 30^\circ$$

$$\Rightarrow BC = a \tan 30 = \boxed{0.578a}$$

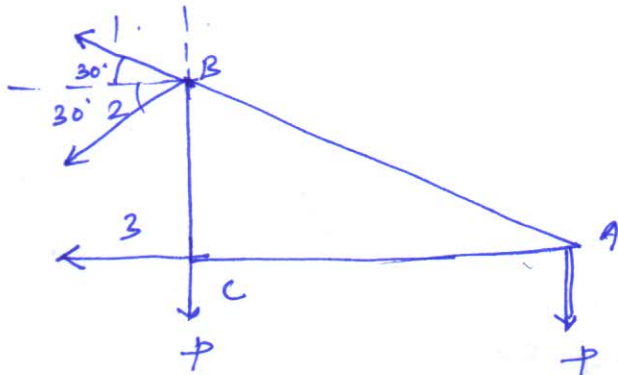

$$\sum M_B = 0$$

$$s_3 \times 0.578a + P \times a = 0$$

$$\Rightarrow s_3 = \frac{-Pa}{0.578a} = -1.73P$$

(-ve sign indicates direction is opposite and it is compressive in nature)

Resolving vertically $\sum Y = 0$

$$s_1 \sin 30 = 2P + s_2 \sin 30$$

$$\Rightarrow s_1 = \frac{2P + s_2/2}{\sin 30} = (4P + s_2) \quad \text{--- (2)}$$

Now resolving horizontally $\sum X = 0$

$$s_1 \cos 30 + s_2 \cos 30 = 1.73P$$

$$\Rightarrow (4P + s_2) \times \frac{\sqrt{3}}{2} + s_2 \frac{\sqrt{3}}{2} = 1.73P$$

$$\Rightarrow 2\sqrt{3}P + \frac{\sqrt{3}}{2}s_2 + \frac{\sqrt{3}}{2}s_2 = 1.73P$$

$$\Rightarrow \frac{\sqrt{3}}{2}s_2 = 1.73P - 2\sqrt{3}P = -1.73P$$

$$\Rightarrow s_2 = \frac{-1.73P}{\sqrt{3}} = \boxed{-P} \quad \text{(-ve sign indicates the direction is opposite and it is compressive)}$$

$$\text{Now } s_1 = 4P - P = \boxed{3P} \quad \text{(tension)}$$

Q.4

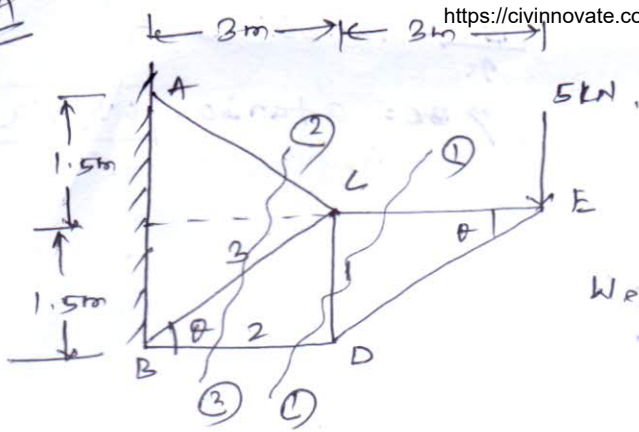

Using method of sections, find axial forces in each bar 1, 2 and 3 of the plane truss.

We have $\tan \theta = \left(\frac{1.5}{3}\right) \Rightarrow \theta = 26.56^\circ$

considering section 1-1

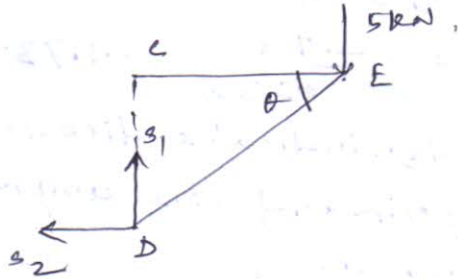

Resolving vertically, $\sum Y = 0$
 $s_1 = 5 \text{ kN}$ (Tension)

Now taking moment about C
 $s_2 \times 1.5 - 5 \times 3 = 0$
 $\Rightarrow s_2 = -10 \text{ kN}$

-ve sign indicates direction should have been opposite

$s_2 = 10 \text{ kN}$ (Compression)

considering section 2-2

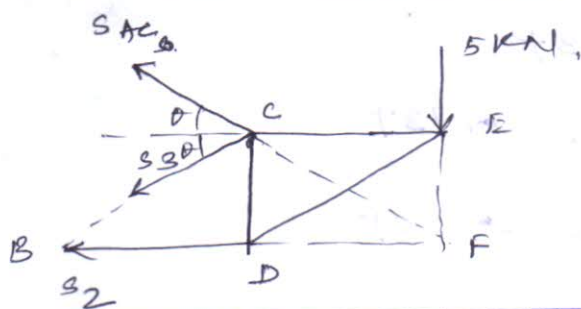

Taking moment about F

$\sum M_F = 0$
 $\Rightarrow s_3 = 0$

Q.5

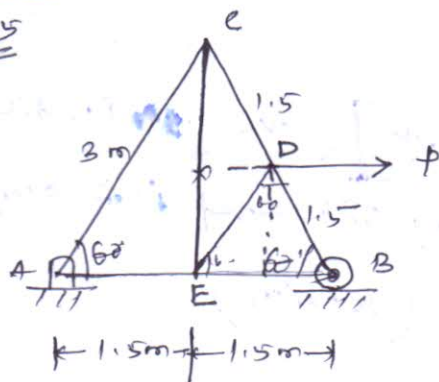

Assignment

Using method of joint and method of section find the axial force in the bar X.

Method of Joint

considering the whole structure and

taking moment about A $\sum M_A = 0$.

$R_B \times 3 = P \times 1.5 \sin 60$

$\Rightarrow R_B = \frac{\sqrt{3}}{4} P$

Q.1 (6.3) Calculate the relation between active forces P and Q for equilibrium of system of bars. The bars are so arranged that they form identical rhombuses.

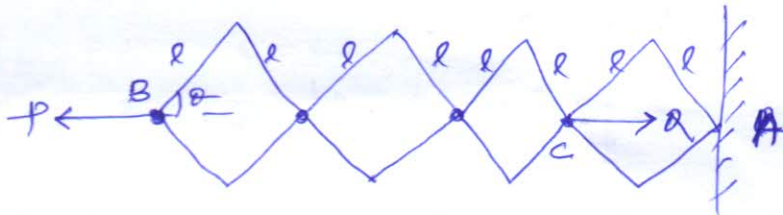

Let l = length of each side of bar.

θ = angle made by each side of the rhombus

Distance of P from fixed point A = $6l \cos \theta$
 " " " " = $2l \cos \theta$

Let the virtual displacement of P is $B-B'$

$$B-B' = dx_1 = \frac{d(6l \cos \theta)}{d\theta} = -6l \sin \theta d\theta$$

Similarly the virtual displacement of Q is $C-C'$
 $= dx_2 = -2l \sin \theta d\theta$

Applying principle of virtual work $\Sigma W = 0$

$$P \cdot dx_1 = Q \cdot dx_2$$

$$\Rightarrow P \cdot (6l \sin \theta d\theta) = Q \cdot (2l \sin \theta d\theta)$$

$$\Rightarrow \boxed{P = \frac{Q}{3}} \quad \text{(Ans)}$$

Q.2 A prismatic bar AB of length l and wt. Q stands in a vertical plane and is supported by smooth surfaces at A and B . Using principle of virtual work find the magnitude of horizontal force P applied at A if the bar is in equilibrium.

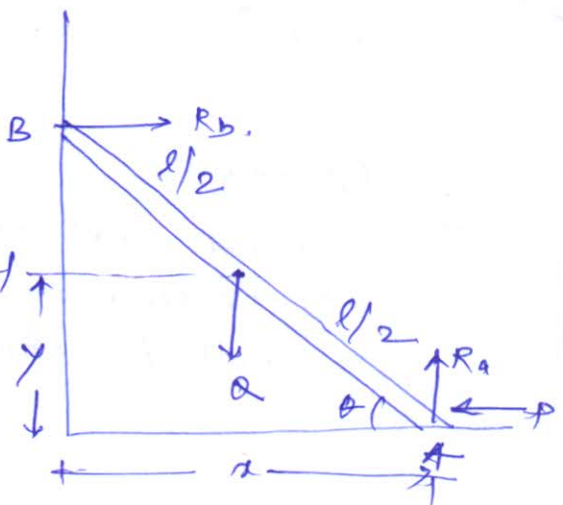

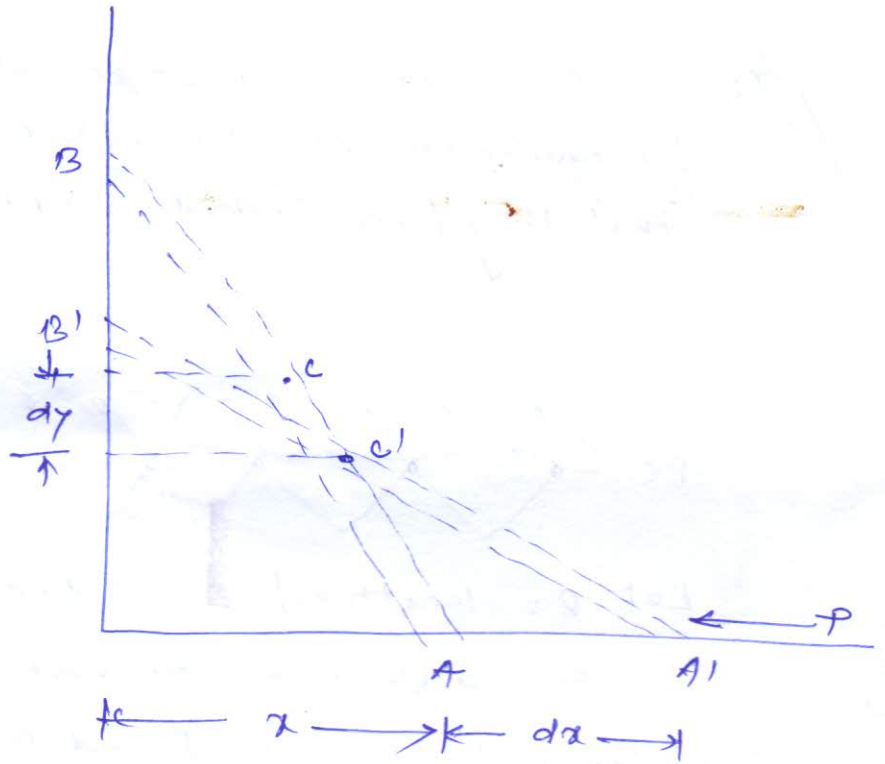

Let the horizontal distance of P from D is x

$$x = l \cos \theta$$

$$AA' = dx = -l \sin \theta d\theta$$

Vertical distance of Q from D is y

$$y = \frac{l}{2} \sin \theta$$

$$cc' = dy = \frac{l}{2} \cos \theta d\theta$$

Normal reactions R_A and R_B have no work along the planes.

Applying principle of virtual work $\sum W = 0$

$$P dx = Q dy$$

$$P l \sin \theta d\theta = Q \frac{l}{2} \cos \theta d\theta$$

$$\Rightarrow \boxed{P = \frac{Q \cdot \cot \theta}{2}}$$

Q.3 (6.14)

Find axial forces in the bars CB of the simple truss by using method of virtual work.

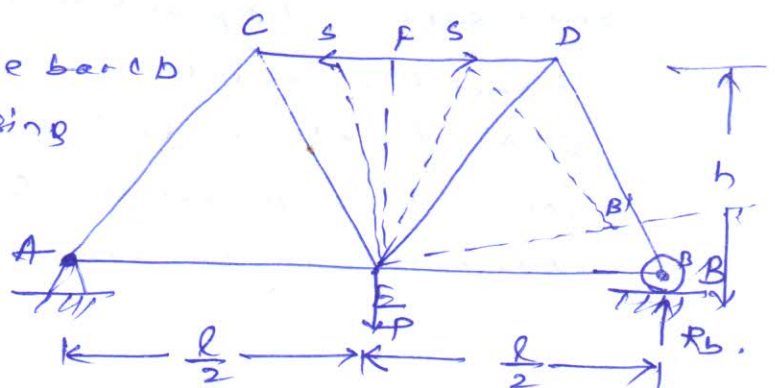

Let s be the compressive force in bar CD .

consider the part $EBDF$ of the truss under the action of force R_b , P and s

Keeping E fixed and giving EB an angular displacement $d\alpha$

$\Sigma W = 0$

$R_b \times BB' = s \times FF'$

$BB' = \frac{l}{2} d\alpha$

$FF' = h d\alpha$

$R_b \times \frac{l}{2} d\alpha = s \times h d\alpha$

$\Rightarrow \boxed{s = \frac{R_b l}{2h}} \text{ --- (1)}$

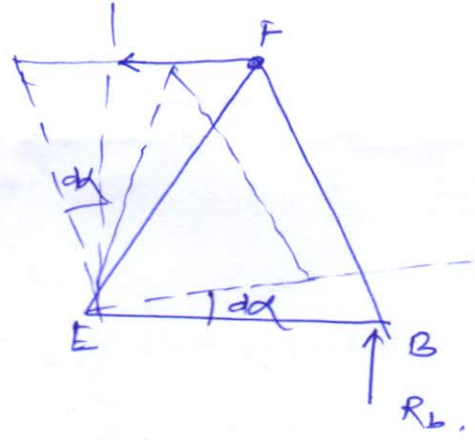

Now considering whole frame as equilibrium body $\Sigma Y = 0$

$R_a + R_b = P$

$R_b \cdot l = P \cdot \frac{l}{2} \Rightarrow \boxed{R_b = \frac{P}{2}} \text{ --- (2)}$

Substituting the value of R_b in eq. (1)

$\boxed{s = \frac{Pl}{4h}} \text{ --- (3)}$

Q.4 (6.15)

Using principle of virtual work find reactions R_a for the truss.

Let the truss is virtual displaced by an amount dy

$\Sigma W = 0$

$R_a \times AA' = P \times DD'$

where $AA' = DD' = dy$

$\Rightarrow \boxed{R_a = P}$

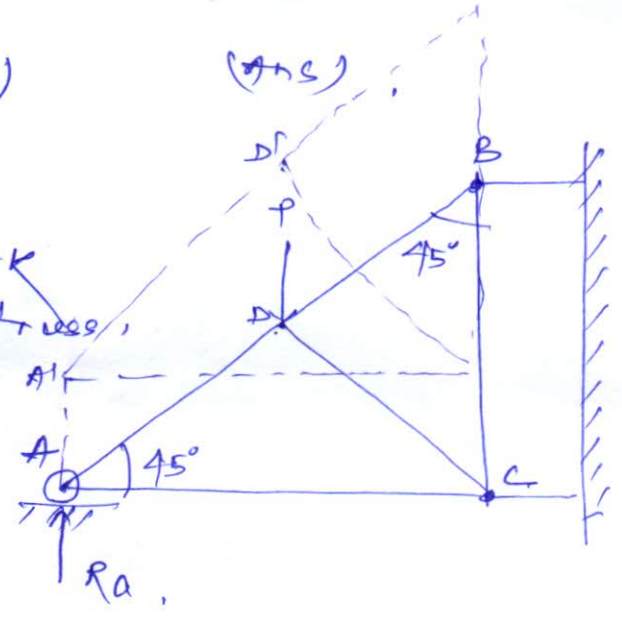

modipada to big bazar
near jashnath
mandir
right hand side

Moment of Inertia of Plane Figures

<https://civinnovate.com/civil-engineering-notes/>

02/12/19

①

The moment of inertia of any plane figure with respect to x and y axes in its plane are expressed as

$$I_{xx} = \int y^2 dA \quad I_{yy} = \int x^2 dA$$

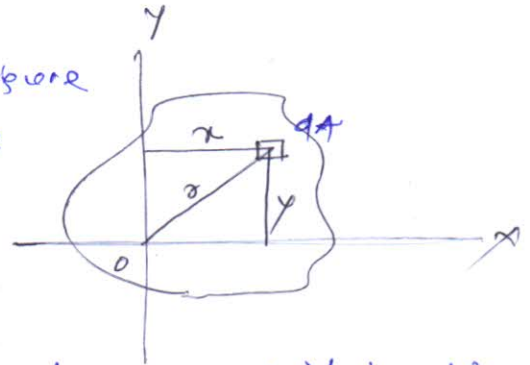

I_{xx} and I_{yy} are also known as second moment of inertia area about the axes as it is distance is squared from corresponding axis.

Unit

Unit of moment of inertia of area is expressed as m^4 or mm^4 .

Moment of Inertia of Plane Figures:-

(i) Rectangle

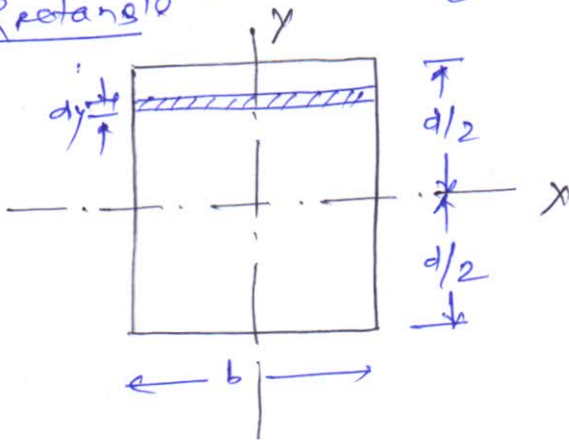

Considering a rectangle of width b and depth d . Moment of inertia about centroidal axis $x-x$ parallel to the short side i.e. b

Now considering an elementary strip of width dy

Moment of inertia of the elemental strip about centroidal axis xx is

$$I_{xx} = y^2 dA \\ = y^2 b dy$$

So moment of inertia of entire ~~figure~~ area

$$I_{xx} = \int_{-d/2}^{d/2} y^2 b dy = b \left[\frac{y^3}{3} \right]_{-d/2}^{d/2} = b \left[\frac{d^3}{24} + \frac{d^3}{24} \right]$$

$$\Rightarrow I_{xx} = \frac{bd^3}{12}$$

Similarly ~~moment~~

$$I_{yy} = \frac{db^3}{12}$$

Cii) Triangle :- (Moment of inertia of a triangle about its base)

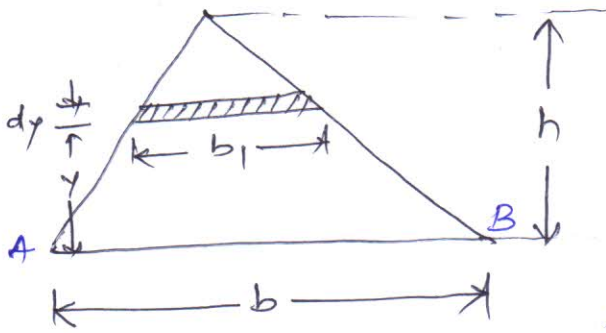

Consider a small elementary strip of thickness dy at a distance y from the base of thickness dy . Let dA is the area of strip

$dA = b_1 dy$
 And $b_1 = \frac{(h-y)}{h} \times b$

Moment of inertia of strip about base AB

$$= y^2 dA = y^2 b_1 dy$$

$$= y^2 \frac{(h-y)}{h} \cdot b dy$$

\therefore Moment of inertia of the triangle about AB

$$I_{AB} = \int_0^h \frac{y^2 (h-y)}{h} b dy = \int_0^h \left(y^2 - \frac{y^3}{h} \right) b dy$$

$$= b \left[\frac{y^3}{3} - \frac{y^4}{4h} \right]_0^h = b \left[\frac{h^3}{3} - \frac{h^4}{4h} \right]$$

$$= b \left[\frac{h^3}{3} - \frac{h^3}{4} \right] = \frac{bh^3}{12}$$

\Rightarrow $I_{AB} = \frac{bh^3}{12}$

Ciii) Moment of inertia of a circle about its centroidal axis

Considering an elementary strip of thickness dr , the side of strip is $r d\theta$.

Moment of inertia of strip about xx

$$= y^2 dA$$

$$= (r \sin \theta)^2 r d\theta dr$$

$$= r^3 \sin^2 \theta d\theta dr$$

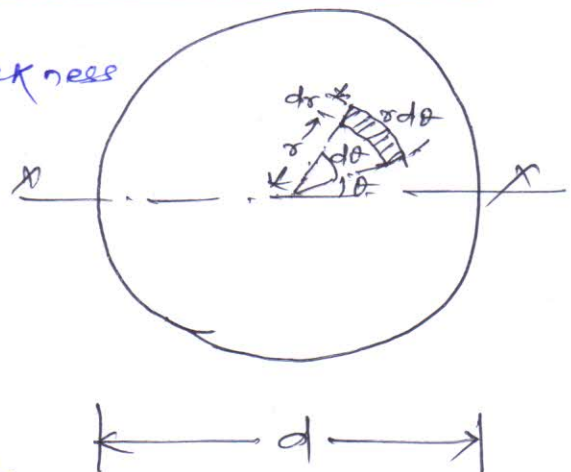

\therefore Moment of inertia of circle about xx axis

$$I_{xx} = \int_0^R \int_0^{2\pi} r^3 \sin^2 \theta d\theta dr$$

$$= \int_0^R \int_0^{2\pi} r^3 \left(\frac{1 - \cos 2\theta}{2} \right) d\theta dr$$

$$= \int_0^R \frac{\sigma^3}{2} \left[\theta - \frac{\sin 4\theta}{2} \right]_0^{2\pi} d\theta$$

$$= \int_0^R \frac{\sigma^3}{2} \left(2\pi - \frac{\sin 4\pi}{2} \right) d\theta$$

$$= \left[\frac{\sigma^4}{8} \right]_0^R [2\pi - 0]$$

$$= \frac{R^4}{8} 2\pi = \frac{\pi R^4}{4}$$

$$\Rightarrow I_{xx} = \frac{\pi R^4}{4} = \frac{\pi D^4}{64}$$

$$\left(\because R = \frac{D}{2} \right)$$

Polar moment of inertia:-

Moment of inertia about an axis perpendicular to the plane of area is called polar moment of inertia. It may be denoted as J or I_{xx} .

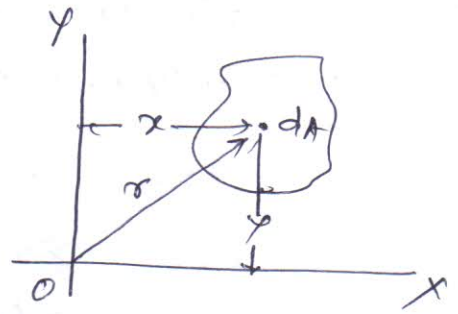

$$I_{xx} = \int \sigma^2 dA$$

Radius of Gyration:-

Radius of gyration may be defined by a relation

$$k = \sqrt{\frac{I}{A}}$$

where k = radius of gyration

I = moment of inertia

A = cross-sectional area

So, we can have the following relations

$$k_{xx} = \sqrt{\frac{I_{xx}}{A}}$$

$$k_{yy} = \sqrt{\frac{I_{yy}}{A}}$$

$$k_{AB} = \sqrt{\frac{I_{AB}}{A}}$$

Theorems of Moment of Inertia

<https://civinnovate.com/civil-engineering-notes/>

There are two theorems of moment of inertia

(a) perpendicular axis theorem

(b) parallel axis theorem.

perpendicular axis theorem:-

Moment of inertia of an area about an axis L to its plane at any point O is equal to the sum of moments of inertia about any two mutually perpendicular axes through the same point O and lying in the plane of area.

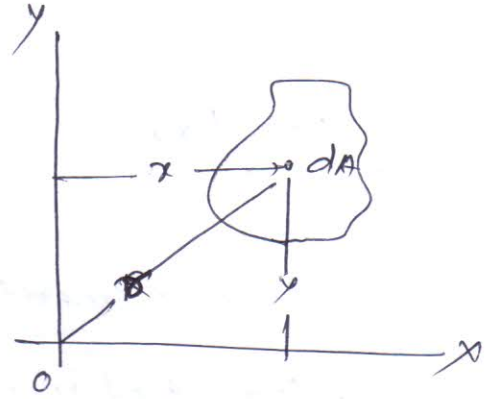

$$I_{zz} = I_{xx} + I_{yy}$$

$$I_{zz} = \sum r^2 dA$$

$$= \sum (x^2 + y^2) dA$$

$$= \sum x^2 dA + \sum y^2 dA$$

$$\Rightarrow \boxed{I_{zz} = I_{xx} + I_{yy}}$$

parallel axis theorem:-

Moment of inertia about an axis in the plane of an area is equal to the sum of moment of inertia about a parallel centroidal axis and the product of area and square of the distance between the two parallel axes.

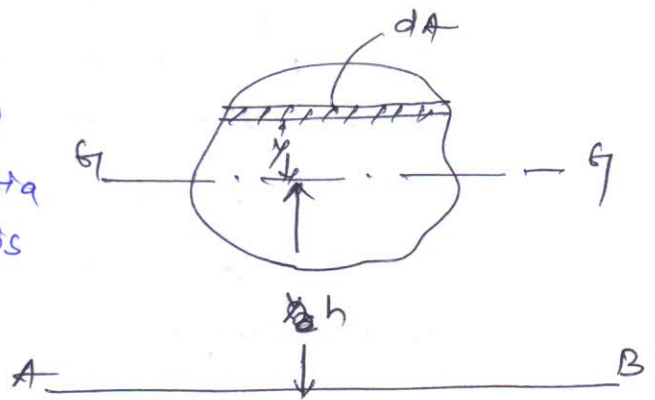

$$\boxed{I_{AB} = I_{GG} + Ah^2}$$

Moment of inertia of standard sections:-

02/12/19

3

Moment of inertia of a rectangle about its centroidal axis xx

$$I_{xx} = \frac{bd^3}{12}$$

Similarly moment of inertia about its centroidal axis yy

$$I_{yy} = \frac{db^3}{12}$$

Now moment of inertia of rectangle about its base AB can be obtained by applying parallel axis theorem

$$\begin{aligned} I_{AB} &= I_{xx} + Ah^2 \\ &= \frac{bd^3}{12} + (bd) \left(\frac{d}{2}\right)^2 \\ &= \frac{bd^3}{12} + \frac{bd^3}{4} \\ &= \frac{3bd^3 + bd^3}{12} = \frac{4bd^3}{12} = \frac{bd^3}{3} \end{aligned}$$

$$\Rightarrow \boxed{I_{AB} = \frac{bd^3}{3}}$$

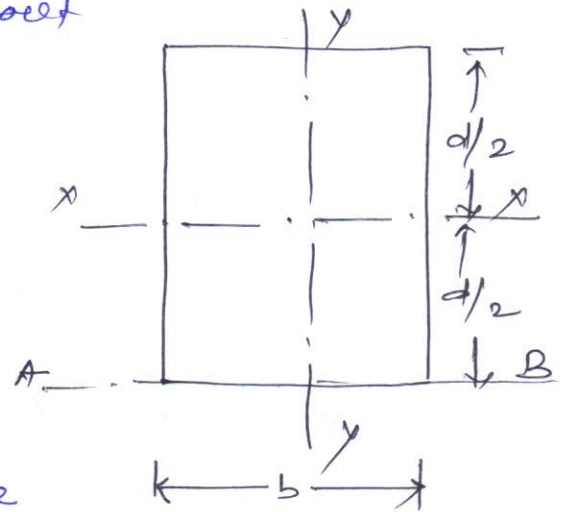

cii) Moment of inertia of a hollow rectangular section:-

Moment of inertia of hollow rectangular section

$$\boxed{I_{xx} = \frac{BD^3}{12} - \frac{bd^3}{12} = \frac{1}{12} (BD^3 - bd^3)}$$

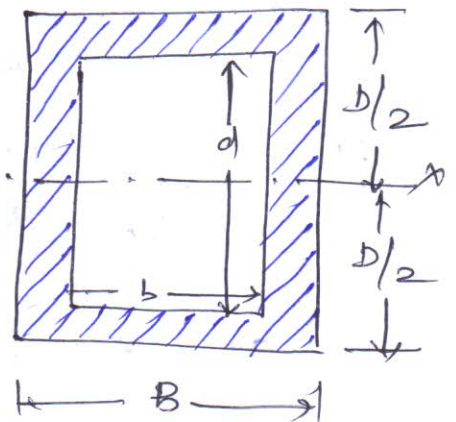

centroidal

ciii) Moment of inertia of triangle about its base <https://civinnovate.com/civil-engineering-notes/>

Moment of inertia of triangle about its base

= moment of inertia about its centroid

$$+ Ah^2$$

(using parallel axis theorem)

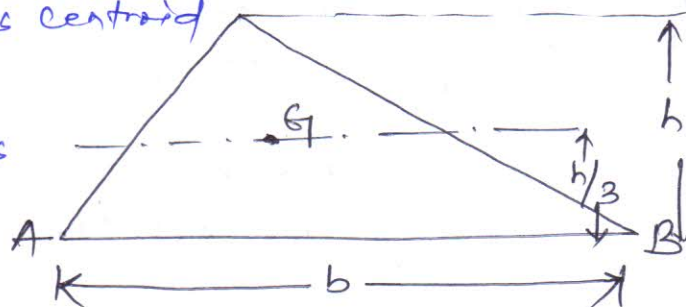

$$\Rightarrow I_{AB} = I_{xx} + Ah^2$$

$$\Rightarrow \frac{bh^3}{12} = I_{xx} + \frac{1}{2}bh \times \left(\frac{h}{3}\right)^2$$

$$= I_{xx} + \frac{bh^3}{18}$$

$$\Rightarrow I_{xx} = \frac{bh^3}{12} - \frac{bh^3}{18} = \frac{6bh^3 - 4bh^3}{18}$$

$$= \frac{2bh^3}{18} = \frac{bh^3}{9}$$

$$\Rightarrow I_{xx} = \frac{bh^3}{36}$$

civ) Moment of inertia of semicircle

(a) about diametral axis

Moment of inertia of semicircle

$$\text{about } AB = \frac{1}{2} \frac{\pi d^4}{64}$$

$$= \frac{\pi d^4}{128}$$

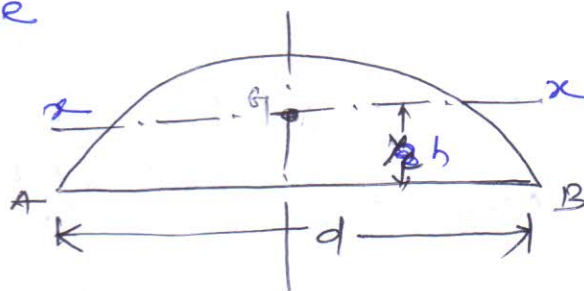

(b) about centroidal axis xx

$$h = \frac{4R}{3\pi} = \frac{2d}{3\pi}$$

$$\text{area } A = \frac{1}{2} \frac{\pi d^2}{4} = \frac{\pi d^2}{8}$$

Using parallel axis theorem

$$I_{AB} = I_{xx} + Ah^2$$

$$\Rightarrow \frac{\pi d^4}{128} = I_{xx} + \frac{\pi d^2}{8} \times \left(\frac{2d}{3\pi}\right)^2 = I_{xx} + \frac{\pi d^4}{18\pi}$$

$$\Rightarrow \frac{\pi d^4}{128} = I_{xx} + \frac{\pi d^2}{8} \times \frac{d^2}{9\pi^2}$$

$$= I_{xx} + \frac{\pi d^4}{18\pi}$$

$$\Rightarrow I_{xx} = \left(\frac{\pi d^4}{128} - \frac{d^4}{18\pi} \right)$$

Moment of inertia of composite figure:-

Q.1 Determine the moment of inertia of the composite section about an axis passing through the centroidal axis. Also determine MI about axis of symmetry and radius of gyration.

Soln Dividing the composite area into A_1 and A_2

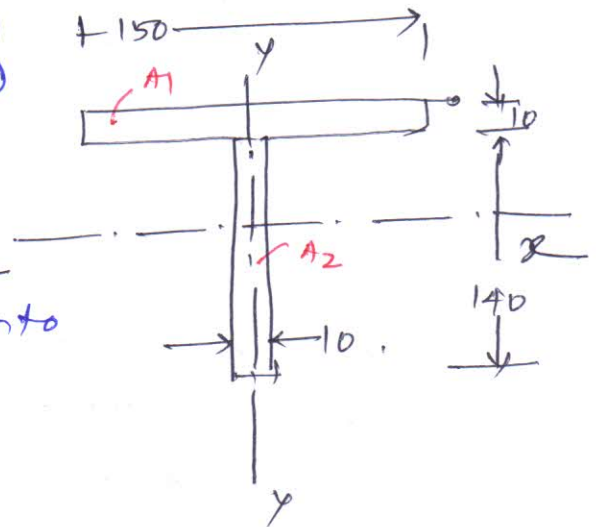

$$A_1 = 150 \times 10 = 1500 \text{ mm}^2$$

$$A_2 = 10 \times 140 = 1400 \text{ mm}^2$$

Distance of centroid from base of the composite figure

$$\bar{y} = \frac{A_1 y_1 + A_2 y_2}{(A_1 + A_2)} = \frac{1500 \times 145 + 1400 \times 70}{2900}$$

$$= 108.79 \text{ mm}$$

Moment of inertia of the area about xx axis

$$I_{xx} = \left\{ \frac{150 \times 10^3}{12} + 1500 \times (145 - 108.79)^2 \right\}$$

$$+ \left\{ \frac{10 \times 140^3}{12} + 1400 \times (108.79 - 70)^2 \right\}$$

$$= (12500 + 1966746.15) + (2286666.667 + 2106529.74)$$

$$= 6372442.557 \text{ mm}^4$$

Similarly

$$I_{yy} = \frac{10 \times 150^3}{12} + \frac{140 \times 10^3}{12} = 2812500 + 11666.66667$$

$$= 2824166.667 \text{ mm}^4$$

Radius of gyration $k = \sqrt{\frac{I}{A}}$
<https://civinnovate.com/civil-engineering-notes/>

$$\text{so } k_{xx} = \sqrt{\frac{I_{xx}}{A}} = \sqrt{\frac{6372442.5}{2900}} = 46.87 \text{ mm}$$

$$\text{Similarly } k_{yy} = \sqrt{\frac{I_{yy}}{A}} = \sqrt{\frac{2824166.667}{2900}} = 31.206 \text{ mm} \quad (\text{Ans})$$

Q.2 Determine the ME of L-section about its centroidal axes parallel to the legs. Also find the polar moment of inertia.

$$\text{We have } A_1 = 125 \times 10 = 1250 \text{ mm}^2$$

$$A_2 = 75 \times 10 = 750 \text{ mm}^2$$

$$\text{Total area } A_1 + A_2 = 2000 \text{ mm}^2$$

Distance of centroid from 1-1 axis

$$\bar{y} = \frac{A_1 y_1 + A_2 y_2}{A_1 + A_2} = \frac{1250 \times 62.5 + 750 \times 5}{2000} = 40.9375 \text{ mm}$$

Distance of centroidal axis yy from 2-2 axis

$$\bar{x} = \frac{A_1 x_1 + A_2 x_2}{A_1 + A_2} = \frac{1250 \times 5 + 750 \times (\frac{75}{2} + 10)}{2000} = \frac{1250 \times 5 + 750 \times 47.5}{2000} = 20.93 \text{ mm}$$

Moment of inertia about xx axis

$$I_{xx} = \left\{ \frac{10 \times 125^3}{12} + 1250 \times (62.5 - 40.9375)^2 \right\} + \left\{ \frac{75 \times 10^3}{12} + 750 \times (40.9375 - 5)^2 \right\}$$

$$= (1627604.167 + 581176.7578) + (6250 + 968627.9297) = 3183658.854 \text{ mm}^4$$

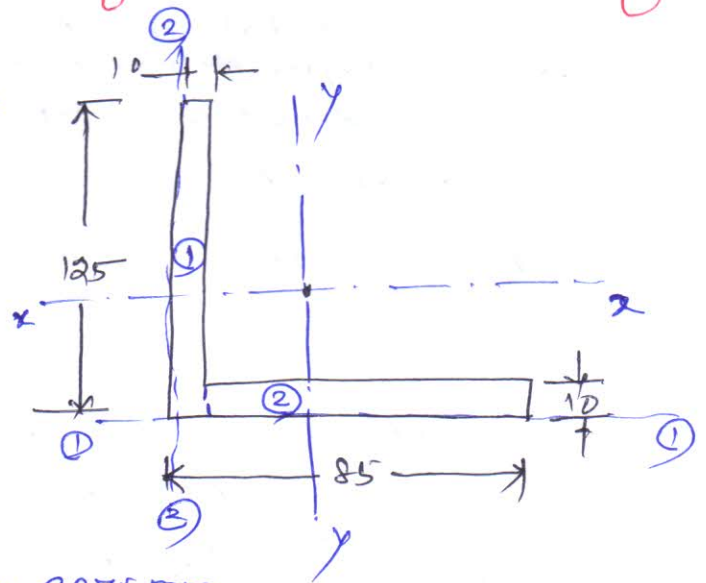

Similarly MI about yy centroidal axis

$$I_{yy} = \left\{ \frac{125 \times 10^3}{12} + 1250 \times (20.93 - 5)^2 \right\} + \left\{ \frac{10 \times 75^3}{12} + 750 \times (47.5 - 20.93)^2 \right\}$$

$$= (10416.66667 + 317206.125) + (351562.5 + 529473.675)$$

$$= \boxed{1208658.967 \text{ mm}^4}$$

Polar moment of inertia $I_{zz} = I_{xx} + I_{yy}$

$$= \boxed{4392317.821 \text{ mm}^4} \quad (\text{Ans})$$

Q.3 Determine the MI of the asymmetrical I section about its centroidal axes x-x and y-y. Also determine the polar moment of inertia of the section.

We have from the figure

$$A_1 = 200 \times 9 = 1800 \text{ mm}^2$$

$$A_2 = \pi \cdot 232 \times 6.7 = 1554.4 \text{ mm}^2$$

$$A_3 = 200 \times 9 = 1800 \text{ mm}^2$$

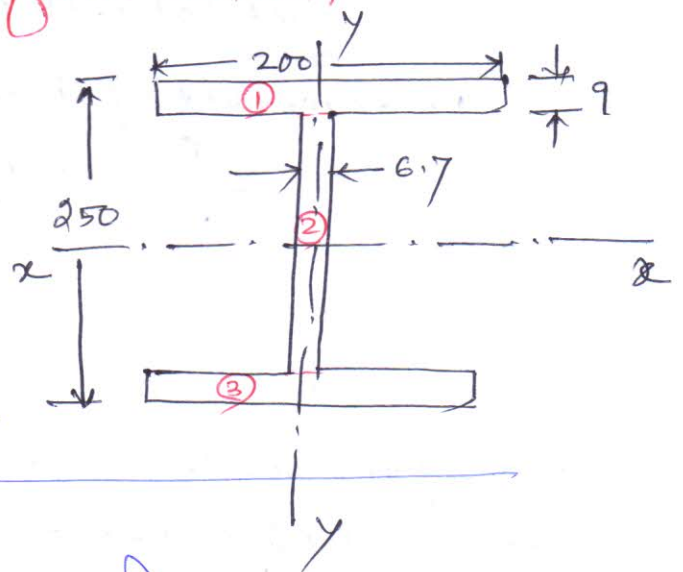

Position of centroidal axis x-x from base

$$\bar{y} = \frac{A_1 y_1 + A_2 y_2 + A_3 y_3}{A_1 + A_2 + A_3}$$

$$= \frac{1800 \times (4.5 + 232 + 9) + 1554.4 \times \left(\frac{232}{2} + 9\right) + 1800 \times 4.5}{(1800 + 1554.4 + 1800)}$$

$$= \frac{1800 \times 245.5 + 1554.4 \times 125 + 1800 \times 4.5}{(1800 + 1554.4 + 1800)}$$

$$= 125 \text{ mm}$$

$$\bar{x} = \frac{A_1 x_1 + A_2 x_2 + A_3 x_3}{A_1 + A_2 + A_3}$$

$$= \frac{1800 \times 100 + 1554.4 \times 96.65 + 1800 \times 100}{(1800 + 1554.4 + 1800)} = 98.98$$

ML about xx axis

<https://civinnovate.com/civil-engineering-notes/>

$$\begin{aligned}
 I_{xx} &= \left\{ \frac{200 \times 9^3}{12} + 1800 \times (125 - 4.5)^2 \right\} + \left\{ \frac{6.7 \times 232^3}{12} + 1554.4 \times (125 - 4.5)^2 \right\} \\
 &+ \left\{ \frac{200 \times 9^3}{12} + 1800 \times (125 - 4.5)^2 \right\} \\
 &= (12150 + 26136450) + (6972002.133 + 0) \\
 &+ (12150 + 26136450) \\
 &= 26148600 + 6972002.133 + 26148600 \\
 &= \boxed{59269202.13 \text{ mm}^4}
 \end{aligned}$$

ML about yy axis

$$\begin{aligned}
 I_{yy} &= \frac{9 \times 200^3}{12} + \frac{232 \times 6.7^3}{12} + \frac{9 \times 200^3}{12} \\
 &= 6000000 + 5814.75 + 6000000 \\
 &= \boxed{12005814.75 \text{ mm}^4}
 \end{aligned}$$

Polar moment of inertia $I_{xx} = I_{xx} + I_{yy}$

$$= \boxed{71275016.88 \text{ mm}^4}$$

Q.4 Calculate the moment of inertia of the shaded area about xx axis.

ML of the shaded section about xx = ML of triangle ABC about xx + ML of semicircle ACS about xx - ML of circle

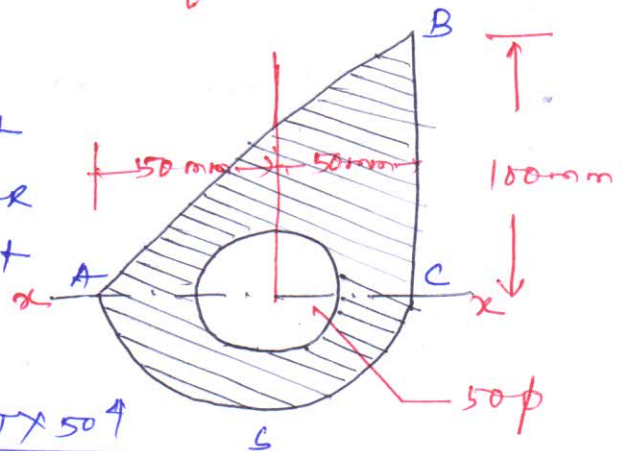

$$= \frac{100 \times 100^3}{12} + \frac{\pi \times 100^4}{128} - \frac{\pi \times 50^4}{64}$$

$$= 8333333.333 + 2454369.261 - 306796.1576$$

$$= 10480906.44 \text{ mm}^4$$

$$= \boxed{1.048 \times 10^7 \text{ mm}^4}$$

- Rectilinear Translation :-

<https://civinnovate.com/civil-engineering-notes/>

In statics, it was considered that the rigid bodies are at rest. In dynamics, it is considered that they are in motion. Dynamics is commonly divided into two branches. Kinematics and kinetics.

In, kinematics we are concerned with space time relationship of a given motion of a body and not at all with the forces that cause the motion.

- In kinetics we are concerned with finding the kind of motion that a given body or system of bodies will have under the action of given forces or with what forces must be applied to produce a desired motion.

Displacement

From the fig. displacement of a particle can be defined by its x -coordinate, measured from the fixed reference point O .



- When the particle is to the right of fixed point O , this displacement can be considered positive and when it is towards the ~~right~~ left hand side it is considered as negative.

General displacement time equation

$$x = f(t) \quad \text{--- (1)}$$

where $f(t)$ = function of time

for example

$$x = c + bt$$

In the above equation c , represents the initial displacement at $t = 0$, while the constant b shows the rate at which displacement increases. It is called uniform rectilinear motion.

Second example is

<https://civinnovate.com/civil-engineering-notes/>

where x is proportional to the square of time.

Velocity

Acceleration

Example The rectilinear motion of a particle is defined by the displacement-time equation $x = x_0 - v_0 t + \frac{1}{2} a t^2$. Construct displacement-time and velocity diagrams for this motion and find the displacement and velocity

at time $t = 2$ s. $x_0 = 750$ mm, $v_0 = 500$ mm/s
 $a = 0.125$ m/s²

The equation of motion is

$$x = x_0 - v_0 t + \frac{1}{2} a t^2 \quad \text{--- (1)}$$

$$v = \frac{dx}{dt} = -v_0 + a t \quad \text{--- (2)}$$

substituting x_0 , v_0 and a in equation (1)

$$x = 750 - 500t + \frac{1}{2} \cdot 0.125 t^2$$

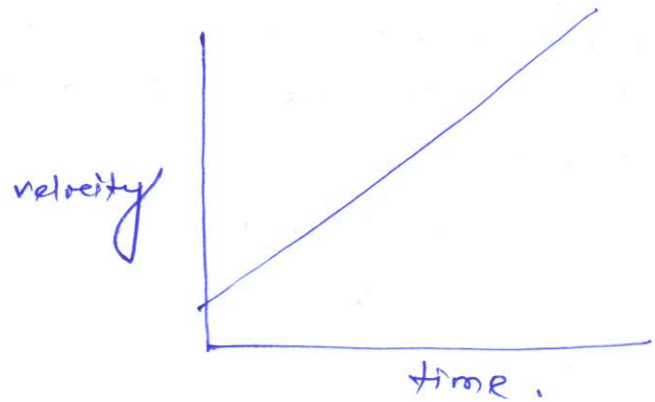
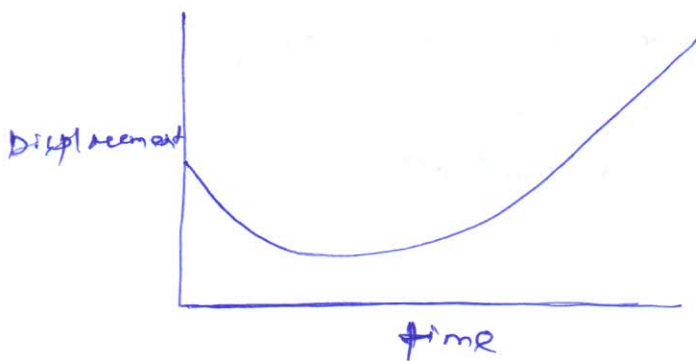

Q-1 A bullet leaves the muzzle of a gun with velocity $u = 750 \text{ m/s}$. Assuming constant acceleration from breech to muzzle find time t occupied by the bullet in travelling through gun barrel which is 750 mm long.

initial velocity of bullet $u = 0$

final velocity of bullet $v = 750 \text{ m/s}$,

total distance $s = 0.75 \text{ m}$.

$t = ?$

We have $v^2 - u^2 = 2as$,

$$\Rightarrow v^2 = 2as \Rightarrow a = \frac{v^2}{2s} = \frac{750^2}{2 \times 0.75} = 375000 \text{ m/sec}^2$$

Again $v = u + at$

$$\Rightarrow 750 = 375000 \times t$$

$$\Rightarrow t = \frac{750}{375000} = \boxed{0.002 \text{ sec}}$$

Q-2 A stone is dropped into well and falls vertically with constant acceleration $g = 9.8 \text{ m/sec}^2$. The sound of impact of stone in the bottom of well is heard after 6.5 sec . If velocity of sound is 336 m/s . How deep is the well?

$$v = 336 \text{ m/sec}$$

Let $s =$ depth of well

$t_1 =$ time taken by the stone into the well

$t_2 =$ time taken by the sound to be heard.

total time $t = (t_1 + t_2) = 6.5 \text{ sec}$.

$$\text{Now } s = ut + \frac{1}{2}gt^2$$

$$\Rightarrow s = 0 + \frac{1}{2}gt^2$$

$$\Rightarrow t_1 = \sqrt{\frac{2s}{g}}$$

When the sound travels with uniform velocity $s = vt_2$ or $t_2 = \frac{s}{v}$

$$\sqrt{\frac{2s}{g} + \frac{h}{v}} = 6.5$$

$$\frac{2s}{g} = \left(6.5 - \frac{h}{v}\right)^2$$

$$\Rightarrow 2s = 9.81 \left(6.5 - \frac{h}{v}\right)^2$$

$$= 9.81 \left(\frac{2184 - s}{336}\right)^2$$

$$= 0.0291 (2184 - s)^2$$

$$= 0.0291 (4769856 + s^2 - 4368s)$$

$$= 138802.809 + 0.0291s^2 - 127.1088s$$

$$\Rightarrow 0.0291s^2 - 127.1088s + 138802.809 = 0$$

$$\Rightarrow s =$$

$$0.2038s = 42.25 + 0.0000885s^2 - 0.0386s$$

~~$$s = 174$$~~

$$0.0000885s^2 - 0.1658s + 42.25 = 0$$

$$s = 17.31 \text{ m}$$

A2

A rope AB is attached at B to a small block of negligible dimensions and passes over a pulley C so that its free end A hangs 1.5 m above ground when the block rests on the floor. The end A of the rope is moved horizontally in a straight line by a man walking with a uniform velocity $v_0 = 3 \text{ m/s}$. Plot the velocity-time diagram.

(b) Find the time t required for the block to reach the pulley if $h = 4.5 \text{ m}$, pulley dimensions are negligible.

A3

A particle starts from rest and moves along a straight line with constant acceleration a . If it acquires a velocity $v = 3 \text{ m/s}$ after having travelled a distance $s = 7.5 \text{ m}$, find magnitude of acceleration.

Principles of Dynamics

<https://civinnovate.com/civil-engineering-notes/>

Newton's law of motion:

First law: Every body continues in its state of rest or of uniform motion in a straight line except in so far as it may be compelled by force to change that state.

Second Law :-

The acceleration of a given particle is proportional to the force applied to it and takes place in the direction of the straight line in which the force acts.

Third law To every action there is always an equal and contrary reaction or the mutual actions of any two bodies are always equal and oppositely directed.

General Equation of Motion of a Particle:

$$ma = f$$

Differential equation of Rectilinear motion:

Differential form of equation for rectilinear motion can be expressed as

$$\frac{W}{g} \ddot{x} = X$$

where \ddot{x} = acceleration

X = Resultant acting force.

Example

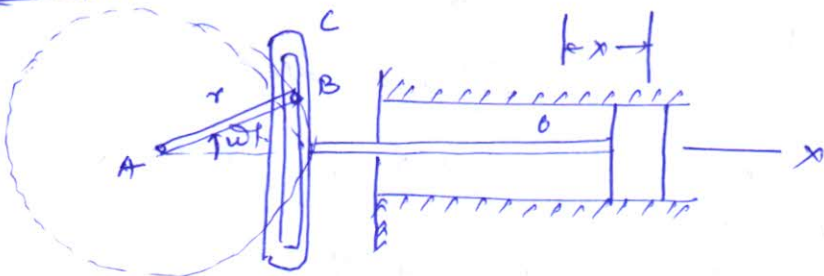

For the engine shown in fig, the combined wt of piston and piston rod $W = 450 \text{ N}$, crank radius $r = 250 \text{ mm}$ and uniform

speed of rotation $n = 120 \text{ rpm}$, determine the magnitude of resultant force acting in piston (a) at extreme position and at the middle position

piston has a simple harmonic motion represented by displacement-time equation

$$x = r \cos \omega t \quad \text{--- (1)}$$

$$\omega = \frac{2\pi n}{60} = \frac{2\pi \times 120}{60} = 4\pi \text{ rad/s.}$$

$$\dot{x} = -r\omega \sin \omega t$$

$$\ddot{x} = -r\omega^2 \cos \omega t \quad \text{--- (2)}$$

Differential equation of motion

$$\frac{W}{g} \ddot{x} = X$$

$$\Rightarrow -\frac{W}{g} r\omega^2 \cos \omega t = X$$

$$\Rightarrow X = -\frac{450}{9.81} \times 0.25 (4\pi)^2 \cos(4\pi t)$$

for extreme position

$$\cos \omega t = -1$$

$$\text{so } X = 1810 \text{ N.}$$

For ~~extreme~~ middle position $\cos \omega t = 0$.

so Resultant force = 0.

E-2

A balloon of gross wt W is falling vertically down ward with constant acceleration a . what amount of ballast Q must be thrown out in order to give balloon an equal upward acceleration a .

P = buoyant force.

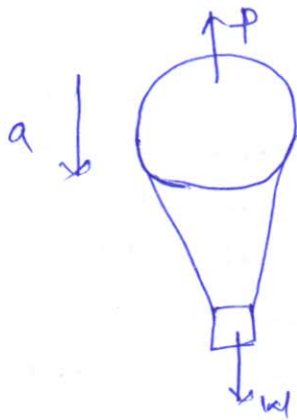

(i)

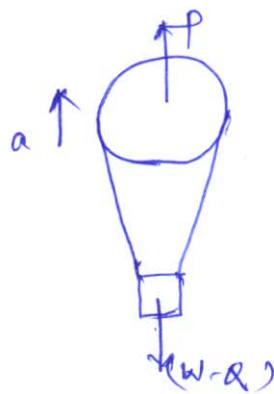

(ii)

(i) considering 1st case when balloon is falling,

$$\frac{W}{g} a = W - P \quad \text{--- (1)}$$

$$\text{(ii) } \frac{W-Q}{g} a = P - (W-Q) \quad \text{--- (2)}$$

$$\text{Eq(1) + Eq(2)}$$

$$\frac{Q}{g} a = W + W - Q = 2W - Q$$

$$\Rightarrow Q \left(\frac{a}{g} + 1 \right) = 2W$$

$$\Rightarrow Q = \frac{2Wg}{(a+g)}$$

$$\frac{W a}{g} = (W - P)$$

<https://civinnovate.com/civil-engineering-notes/>

$$\frac{(W - R) a}{g} = P - (W - R)$$

$$\frac{W a + (W - R) a}{g} = W - P + P - (W - R) = R$$

$$\Rightarrow \frac{W a + W a - R a}{g} = R$$

$$\Rightarrow 2 W a = R g + R a$$

$$\Rightarrow R = \frac{2 W a}{(g + a)}$$

Q-1
 A wt = $W = 4450\text{N}$ is supported in a vertical plane by strings and pulleys arranged shown in fig. If the free end A of the string is pulled vertically downward with constant acceleration $a = 18\text{m/s}^2$ find tension S in the string.

Differential equation of motion for the system is

$$2S - W = \frac{W}{g} \times \frac{a}{2}$$

$$\Rightarrow 2S = W + \frac{W a}{2g}$$

$$= \frac{W}{2} \left(2 + \frac{a}{g} \right)$$

$$= W \left(1 + \frac{a}{2g} \right)$$

$$\Rightarrow S = \frac{W}{2} \left(1 + \frac{a}{2g} \right)$$

$$= \frac{4450}{2} \left(1 + \frac{18}{2 \times 9.81} \right) = \boxed{4266.28 \text{ N}}$$

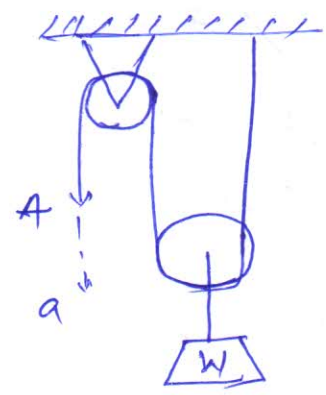

$$\frac{W a}{g} = (W - P)$$

$$\frac{(W - Q) a}{g} = P - (W - Q)$$

$$\frac{W a + (W - Q) a}{g} = W - P + P - (W - Q) = Q$$

$$\Rightarrow \frac{W a + W a - Q a}{g} = Q$$

$$\Rightarrow 2 W a = Q g + Q a$$

$$\Rightarrow Q = \frac{2 W a}{(g + a)}$$

Q.1

A wt. $W = 4450 \text{ N}$ is supported in a vertical plane by strings and pulleys arranged shown in fig. If the free end A of the string is pulled vertically downward with constant acceleration $a = 18 \text{ m/s}^2$ find tension S in the string.

Differential equation of motion for the system is

$$2S - W = \frac{W}{g} \times \frac{a}{2}$$

$$\Rightarrow 2S = W + \frac{W a}{2g}$$

$$= \frac{W}{2} \left(2 + \frac{a}{g} \right)$$

$$\Rightarrow S = \frac{W}{2} \left(1 + \frac{a}{2g} \right)$$

$$= \frac{4450}{2} \left(1 + \frac{18}{2 \times 9.81} \right) = \boxed{4266.28 \text{ N}}$$

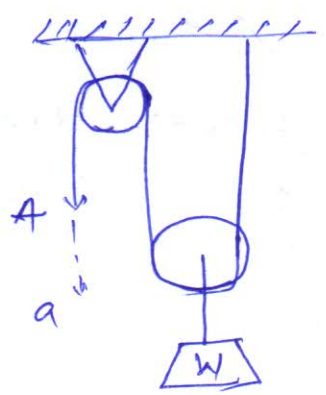

Q. 2

An elevator of gross wt $W = 4450\text{ N}$ starts to move upward direction with a constant acceleration and acquires a velocity $v = 18\text{ m/s}$; after travelling a distance $= 1.8\text{ m}$. find tensile force S in the cable during its motion.

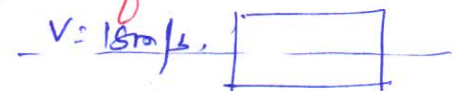

$W = 4450\text{ N}$.

$V = 18\text{ m/s}$.

initial velocity $u = 0$

distance travelled $x = 1.8\text{ m}$,

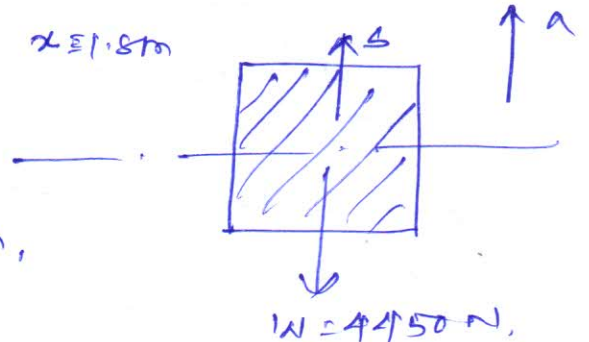

$S - W = \frac{W}{g} \cdot a$

$\Rightarrow S = W + \frac{W}{g} a = W \left(1 + \frac{a}{g} \right) \text{ --- (1)}$

Now applying equation of kinematics

$v^2 - u^2 = 2as$

$\Rightarrow 18^2 - 0 = 2a \times 1.8$

$\Rightarrow a = \frac{18^2}{2 \times 1.8} = \boxed{90\text{ m/s}^2}$

substituting the value of a in eq. (1)

$S = 4450 \left(1 + \frac{90}{9.81} \right) = \boxed{45275.7\text{ N}}$

A-1
Q. 3

A train weighing 1870 N without the locomotive starts to move with constant acceleration along a straight track and in first 60 s acquires a velocity of 56 kmph . Determine the tension S in draw bar between locomotive and train if the air resistance is 0.005 times the wt. of the train.

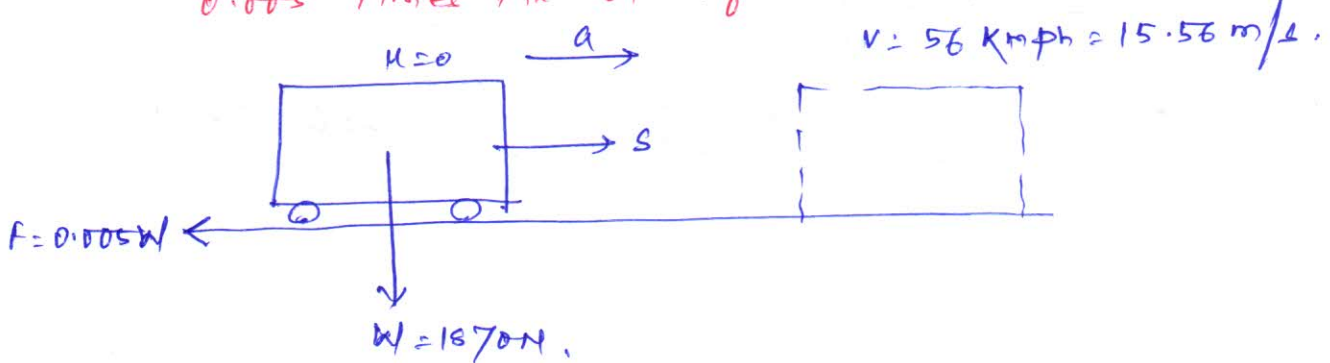

$$S - F = \frac{W}{g} \cdot a$$

$$\Rightarrow S = 0.005W + \frac{W a}{g} \quad \text{--- (1)}$$

from eq. of kinematics,

$$v = u + at$$

$$\Rightarrow a = \left(\frac{15.56 - 0}{60} \right) = 0.26 \text{ m/sec}^2$$

substituting the value of a in eq. (1)

$$S = W \left(0.005 + \frac{a}{g} \right)$$

$$= 1570 \left(0.005 + \frac{0.26}{9.81} \right) = \boxed{58.9 \text{ kN}}$$

A-2
0.1

A wt. W is attached to the end of a small flexible rope of dia. $d = 6.25 \text{ mm}$, and is raised vertically by winding the rope on a reel. If the reel is turned uniformly at a rate of 2 rps. what will be the tension in rope.

dia of rope $d = 6.25 \text{ mm} = 0.00625 \text{ m}$,

No of revolutions $N = 2 \text{ rps}$,

let x = initial radius of reel,

t = time taken for N revolutions,

Net radius after t sec,

$$R = [x + Nt d]$$

Now mean velocity $v = R \omega$

$$\omega = 2\pi N$$

$$\therefore v = (x + Nt d) 2\pi N$$

$$\text{acceleration of rope} = a = \frac{dv}{dt}$$

$$a = \frac{d}{dt} [2\pi N x + 2\pi N^2 t d] = 2\pi N^2 d$$

$$S - W = \frac{W}{g} \cdot a \Rightarrow S = W + \frac{W a}{g} = W \left(1 + \frac{a}{g} \right)$$

$$\Rightarrow S = W \left(1 + \frac{2\pi N^2 d}{g} \right)$$

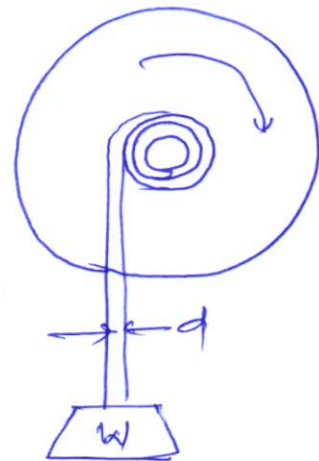

$$\Rightarrow S = W \left(1 + \frac{27 \times 2^2 \times 0.00625}{9.81} \right)$$

=

Ass-3

Q.5

A mine cage of wt $W = 8.9 \text{ kN}$ starts from rest and moves downward with constant acceleration travelling a distance $s = 30 \text{ m}$ in 10 sec . Find the tensile force in the cable.

Wt. of cage $W = 8.9 \text{ kN}$.

initial velocity $u = 0$.

distance travelled $s = 30 \text{ m}$

time $t = 10 \text{ sec}$.

$$s = ut + \frac{1}{2} at^2$$

$$\Rightarrow 30 = \frac{1}{2} a \times 10^2$$

$$\Rightarrow t = \frac{60}{10^2} = \boxed{0.6 \text{ m/sec}^2}$$

Differential equation of rectilinear motion

$$W - S = \frac{W}{g} \cdot a$$

$$\Rightarrow S = W - \frac{W}{g} a = W \left(1 - \frac{a}{g} \right)$$

$$= 8.9 \left(1 - \frac{0.6}{9.81} \right)$$

$$\Rightarrow \boxed{S = 8.35 \text{ kN.}}$$

(Ans)

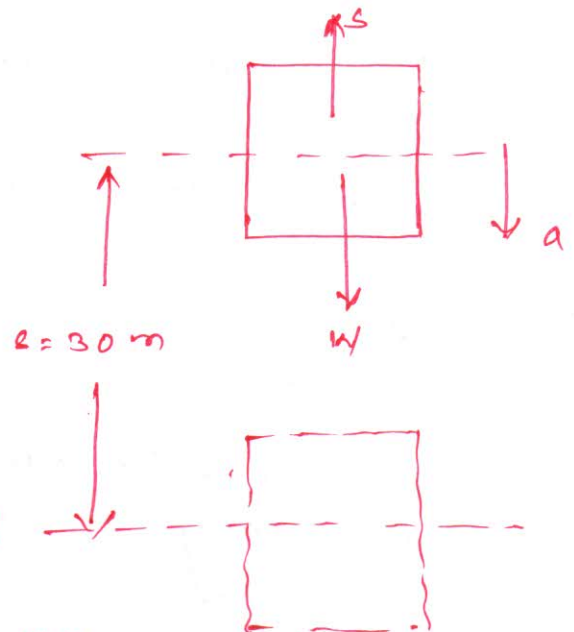

D'Alembert's Principle

<https://civinnovate.com/civil-engineering-notes/>

25/11/14

①

Differential equation of motion (rectilinear) can be written as

$$X - m\ddot{x} = 0 \quad \text{--- (1)}$$

Where X = Resultant of all applied force in the direction of motion

m = mass of the particle

The above equation may be treated as equation of dynamic equilibrium. To represent this equation, in addition to the real forces acting on the particle a fictitious force $m\ddot{x}$ is required to be considered. This force is equal to the product of mass of the particle and its acceleration and directed ⁱⁿ opposite direction, and is called the inertia force of the particle.

$$- \sum m\ddot{x} = -\ddot{x} \sum m = -\frac{W}{g} \ddot{x}$$

Where W = total weight of the body

So the equation of dynamic equilibrium can be expressed as:

$$\sum X_i + \left(-\frac{W}{g} \ddot{x} \right) = 0 \quad \text{--- (2)}$$

Example 1

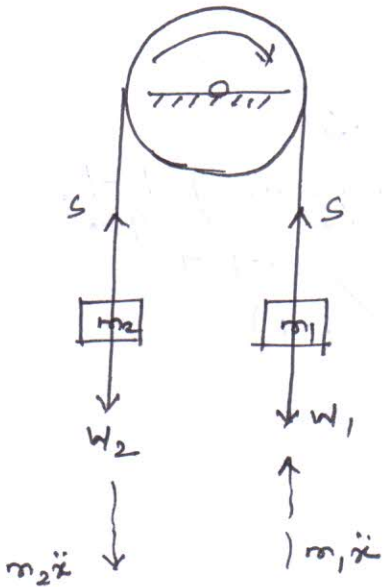

for the example shown considering the motion of pulley as shown by the arrow mark. we have upward acceleration \ddot{x}_2 for W_2 and downward acceleration \ddot{x}_1 for W_1

- corresponding inertia forces and their direction are indicated by dotted line.

- By adding inertia forces to the real forces (such as W_1, W_2 and tension in strings) we obtain, for each particle, a system of

forces in equilibrium.

The equilibrium equation for the entire system without S

$$W_2 + m_2 \ddot{x} = W_1 - m_1 \ddot{x}$$

$$\Rightarrow (m_1 + m_2) \ddot{x} = (W_1 - W_2) \Rightarrow \ddot{x} = \frac{W_1 - W_2 \cdot g}{(W_1 + W_2)}$$

Example 2

A body is moving up with acceleration by a rope.

So the equation of dynamic equilibrium considering the real and inertia forces.

$$S - W - \frac{W}{g} a = 0, \text{ so tensile force in rope}$$

$$\Rightarrow S = W \left(1 + \frac{a}{g} \right)$$

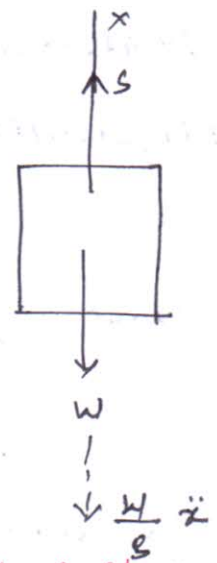

Q.1
X

Find tension S in the string during motion of the system
 (a) if $W_1 = 900\text{N}$, $W_2 = 450\text{N}$. Take μ betn the inclined plane and block $W_1 = 0.2$

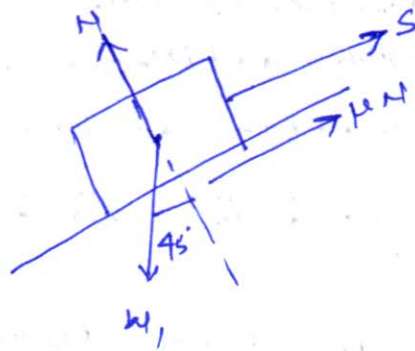
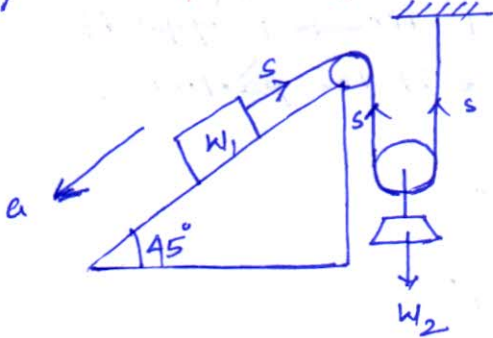

When W_1 moves downward in the inclined plane with an acceleration a , then acceleration of $W_2 = \frac{a}{2}$

Considering dynamic equilibrium of W_1 , from D'Alembert's principle

$$(W_1 \sin 45^\circ - \mu N - S) - \frac{W_1}{g} a = 0$$

$$\Rightarrow \frac{W_1}{g} a = W_1 \sin 45^\circ - \mu N - S$$

$$= W_1 \sin 45^\circ - \mu W_1 \cos 45^\circ - S$$

$$\Rightarrow a = \left(900 \times \frac{1}{\sqrt{2}} - 0.2 \times 900 \times \frac{1}{\sqrt{2}} - S \right) \frac{9.81}{900}$$

$$\Rightarrow a = \frac{636.4 - 127.28 - S}{554.9} \times 0.0109$$

$$\Rightarrow a = \frac{509.12 - S}{554.9} \times 0.0109 \quad \text{--- (1)}$$

Similarly for weight W_2

$$2S - W_2 - \frac{W_2}{g} \frac{a}{2} = 0$$

$$\Rightarrow \frac{W_2 a}{2g} = 2S - W_2 \left(1 + \frac{a}{2g} \right) = 2S$$

$$\Rightarrow 2S = \frac{450}{2} \left(1 + \frac{a}{19.62} \right) = 225 + 11.46 a \quad \text{--- (2)}$$

substituting the value of S in eq. (1)

$$a = \frac{5.549 - 2.4525 - 0.125a}{554.9} \Rightarrow a =$$

25/1/14

(2)

$$a = 6.93676 - 1.30722 - 0.124914a$$

$$= 5.549408 - 0.124914a$$

$$= 3.096908 - 0.124914a$$

$$\Rightarrow \boxed{a = 2.75 \text{ m/s}^2}$$

Q.2 Two weights P and Q are connected by the arrangement shown in fig. Neglecting friction and inertia of pulley and cord find the acceleration a of wt-Q. Assume P = 178 N, Q = 133.5 N.

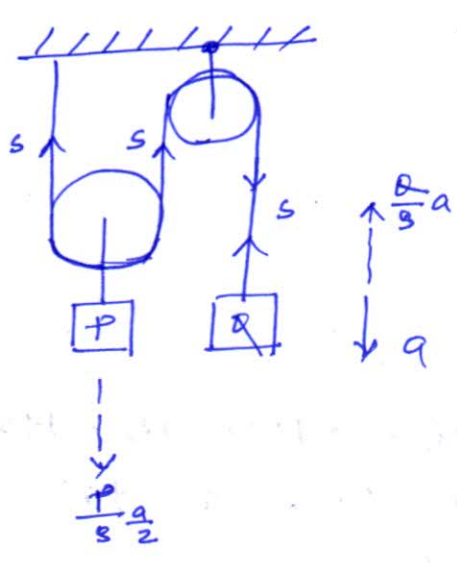

Applying D'Alembert's principle for Q

$$Q - s - \frac{Q}{g} a = 0$$

$$\Rightarrow s = \frac{Q}{g} \left(1 - \frac{a}{g} \right) \quad \text{--- (1)}$$

$$= 133.5 \left(1 - \frac{a}{9.81} \right)$$

Applying D'Alembert's principle to P

~~P = 178 N~~

$$2s - P - \frac{P}{2g} a = 0$$

$$\Rightarrow 2s = P \left(1 + \frac{a}{2g} \right)$$

$$\Rightarrow s = \frac{P}{2} \left(1 + \frac{a}{2g} \right) \quad \text{--- (2)}$$

$$= \frac{178}{2} \left(1 + \frac{a}{19.62} \right)$$

$$133.5 \left(1 - \frac{a}{9.81} \right) = 89 \left(1 + \frac{a}{19.62} \right)$$

$$\Rightarrow 133.5 - 13.608a = 89 + 4.536a$$

$$\Rightarrow 18.144a = 44.5$$

$$\Rightarrow \boxed{a = 2.45 \text{ m/s}^2} \quad \text{(Ans)}$$

Q.3 Assuming the car in the fig. to have a velocity of 6 m/s find shortest distance s in which it can be stopped with constant deceleration without disturbing the block. Data: c = 0.6 m, h = 0.9 m, $\mu = 0.5$

Q.3 Two blocks of weight $W_1 = 150\text{ N}$ and $W_2 = 500\text{ N}$ are connected by an inextensible string. Find the accelerations of the blocks and tension in the string. $\mu_1 = 0.1$, $\mu_2 = 0$.

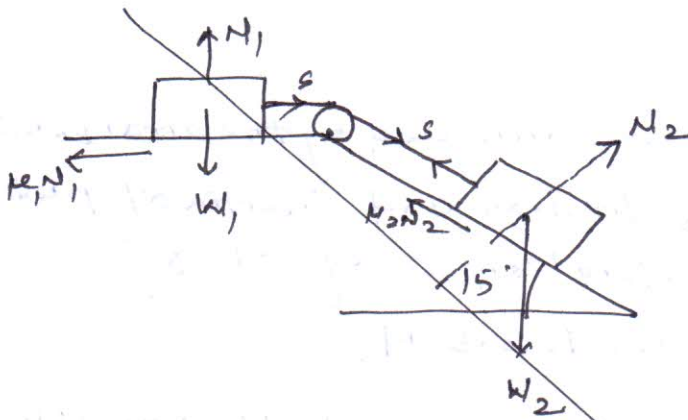

For block 1

$$S - \mu_1 N_1 = 0$$

$$\Rightarrow S = \mu_1 W_1 = 0.1 \times 150 = 15\text{ N}$$

For block 2

Q.3

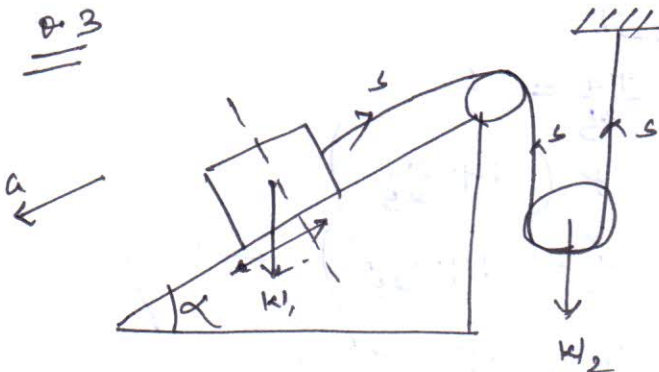

$$W_1 = 890\text{ N} \quad W_2 = 445\text{ N}$$

$$\mu = 0.2 \quad \alpha = 45^\circ$$

find s .

considering equilibrium of W_1 and applying D'Alembert's principle

$$W_1 \sin 45^\circ - \mu N_1 - S - \frac{W_1}{g} a = 0$$

$$\begin{aligned} \Rightarrow S &= W_1 \sin 45^\circ - \mu N_1 - \frac{W_1}{g} a \\ &= \frac{890}{\sqrt{2}} - 0.2 \times 890 \times \frac{1}{\sqrt{2}} - \frac{890}{9.81} a \\ &= 629.32 - 125.865 - 90.729 a \end{aligned}$$

$$\boxed{S = 503.455 - 90.729 a} \quad \text{--- (1)}$$

Applying D'Alembert's principle for W_2

$$2S - W_2 - \frac{W_2}{g} a = 0$$

$$\Rightarrow 2S = W_2 \left(1 + \frac{a}{2g} \right)$$

$$\Rightarrow S = \frac{W_2}{2} \left(1 + \frac{a}{2g} \right) = \frac{445}{2} \left(1 + \frac{a}{19.62} \right) = 222.5 + 11.34 a \quad \text{--- (2)}$$

Equating (1) and (2)

<https://civinnovate.com/civil-engineering-notes/>

25/11/14

(3)

$$503.455 - 90.72a = 222.5 + 11.34a$$

$$\Rightarrow 102.6604a = 280.955$$

$$\Rightarrow a = 2.75 \text{ m/s}^2$$

$$\text{So } S = 222.5 + 11.34 \times 2.75 = 253.71 \text{ N.}$$

Q4

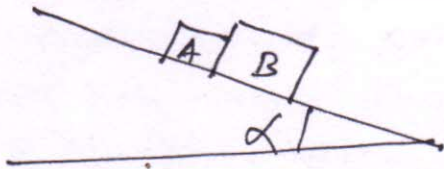

$$W_A = 44.5 \text{ N} \quad W_B = 89 \text{ N}$$

$$\alpha = 30^\circ \quad \mu_a = 0.15$$

$$\mu_B = 0.3$$

find pressure P bet'n blocks.

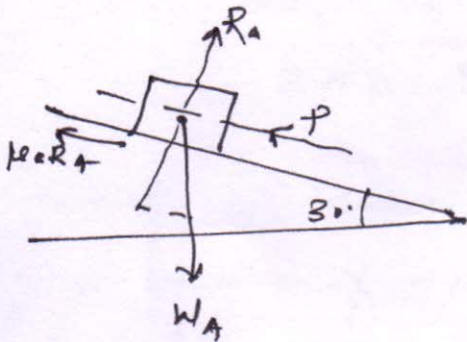

$$W_A \sin 30 - P - \mu_a R_A - \frac{W_A}{g} a = 0$$

$$\Rightarrow P = W_A \sin 30 - \mu_a R_A - \frac{W_A}{g} a$$

$$= 44.5 \times \frac{1}{2} - 0.15 \times 44.5 \times \cos 30 - \frac{44.5}{9.81} a$$

$$= 22.25 - 5.78 - 4.53a \quad \text{--- (1)}$$

$$= 16.47 - 4.53a \quad \text{--- (1)}$$

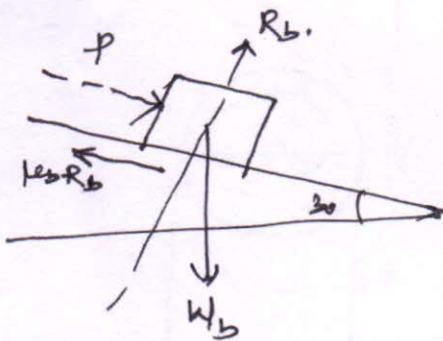

$$P + W_B \sin 30 - \mu_B R_B - \frac{W_B}{g} a = 0$$

$$\Rightarrow P = -\frac{W_B}{2} + 0.3 \times 89 \cos 30 + \frac{89}{9.81} a$$

$$= -\frac{89}{2} + 23.122 + 9.07a$$

$$= -21.378 + 9.07a \quad \text{--- (2)}$$

$$16.47 - 4.53a = -21.378 + 9.07a$$

$$\Rightarrow 13.6a = 37.848$$

$$\Rightarrow a = 2.78 \text{ m/s}^2$$

$$P = 3.87 \text{ N.}$$

We have the differential equation of rectilinear motion of a particle

$$\frac{W}{g} \dot{x} = X$$

Above equation may be written as

$$\frac{W}{g} \frac{dx}{dt} = X$$

$$\text{or } \boxed{d\left(\frac{W}{g} \dot{x}\right) = X dt} \quad \text{--- (1)}$$

In the above equation we will assume force X as a function of time represented by a force time diagram.

The righthand side of eq. (1) is then represented by the area of shaded elemental strip of height X and width dt . This quantity i.e.

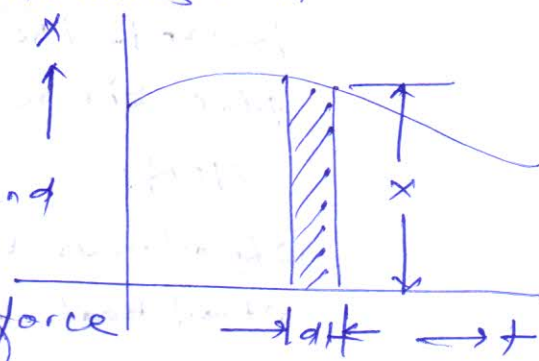

$(X dt)$ is called impulse of the force X in time dt . The expression on the left hand side of the expression $\left(\frac{W}{g} \dot{x}\right)$ is called momentum of particle.

so the eq. (1) represents the differential change in momentum of a particle in time dt .

Integrating eq. (1) we have

$$\boxed{\frac{W}{g} \dot{x} + C = \int_0^t X dt} \quad \text{--- (2)}$$

where C is a constant of integration

Now assuming an initial moment, $t=0$, the particle has an initial velocity \dot{x}_0

$$\text{so } \boxed{C = -\frac{W}{g} \dot{x}_0} \quad \text{--- (3)}$$

so equation (2) becomes

$$\boxed{\frac{W}{g} \dot{x} - \frac{W}{g} \dot{x}_0 = \int_0^t X dt} \quad \text{--- (4)}$$

From equation (4) it is clear that the total change in momentum of a particle during a finite interval of time is equal to the impulse of acting force.

in other words

$$F \cdot dt = d(mv)$$

where $m \times v =$ momentum

Example 2

A man of wt 712 N stands in a boat so that he is 4.5 m from a pier on the shore. He walks 2.4 m in the boat towards the pier and then stops. How far from the pier will he be at the end of time. Wt. of boat is 890 N.

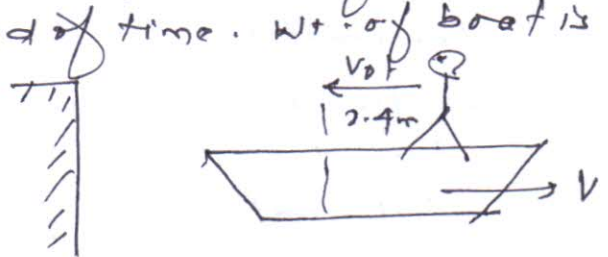

wt of man $w_1 = 712 \text{ N}$

wt of boat $w_2 = 890 \text{ N}$

Let v_0 is the initial velocity of man and t is time

then $v_0 t = x$

$$\Rightarrow v_0 t = 2.4 \text{ m}$$

$$\Rightarrow v_0 = \left(\frac{2.4}{t} \right) \text{ m/s.}$$

Let $v =$ velocity of boat towards right according to conservation of momentum

$$w_1 v_0 = (w_1 + w_2) v$$

$$\Rightarrow v = \frac{w_1 v_0}{(w_1 + w_2)}$$

distance covered by boat

$$s = v \cdot t = \frac{w_1 v_0}{(w_1 + w_2)} \cdot t$$

$$\Rightarrow s = \frac{712 \times 2.4}{712 + 890} = \boxed{1.067 \text{ m}}$$

position of mass from pier <https://civinnovate.com/civil-engineering-notes/>

$$= 4.5 + s - x$$

$$= 4.5 + 1.567 - 2.4 = \boxed{3.167 \text{ m}} \quad (\text{Ans})$$

0.2

A locomotive wt 534 kN has a velocity of 16 kmph and backs into a freight car of wt 86 kN that is at rest on a track. after coupling, at what velocity v the entire system continues to move. Neglect friction.

conservation of momentum

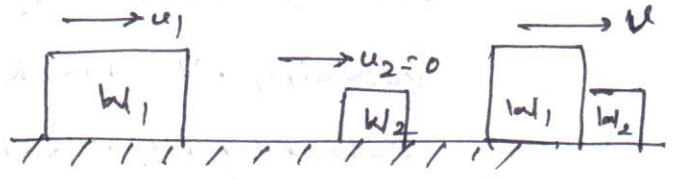

$$W_1 u_1 + W_2 u_2 = (W_1 + W_2) v$$

$$\Rightarrow v = \frac{534 \times 4.45}{(534 + 86)} = \boxed{3.82 \text{ m/s}}$$

0.3

A 667.5 man sits in a 333.75 N canoe and fire a rifle bullet horizontally. ~~directed over~~ find velocity v with which the canoe will move after the shot. the rifle has a muzzle velocity 660 m/s and wt. of bullet is 0.28 N.

Wt. of man $W_1 = 667.5 \text{ N}$.

Wt. of canoe $W_2 = 333.75 \text{ N}$.

Wt. of bullet $W_3 = 0.28 \text{ N}$.

velocity of muzzle $u = 660 \text{ m/s}$.

$V =$ final velocity of canoe.

According to conservation of momentum

~~$$W_3 u = (W_1 + W_2) V$$~~

$$\Rightarrow V = \frac{0.28 \times 660}{(667.5 + 333.75)} = \boxed{0.182 \text{ m/s}}$$

Q.4

A wood block wt 22.25 N rests on a smooth horizontal surface. A revolver bullet weighing 0.14 N is shot horizontally into the side of block. If the block attains a velocity of 3 m/s what is muzzle velocity.

Wt. of wood block $W_1 = 22.25\text{ N}$.

Wt. of bullet $W_2 = 0.14\text{ N}$.

velocity of block $v = 3\text{ m/s}$.

velocity of muzzle = u

According to conservation of momentum

$$W_2 u = (W_1 + W_2) v$$

$$\Rightarrow u = \frac{(22.25 + 0.14) 3}{0.14}$$

$$= \boxed{479.98\text{ m/s}}$$

Conservation of momentum

When the sum of impulses due to external forces is zero the momentum of the system remain conserved

$$\text{When } \sum \int^t X dt = 0$$

$$\boxed{\sum \left(\frac{W}{g}\right) x_2 = \sum \left(\frac{W}{g}\right) x_1}$$

\therefore final momentum = initial momentum.

When a moving particle describes a curved path it is said to have curvilinear motion.

Displacement

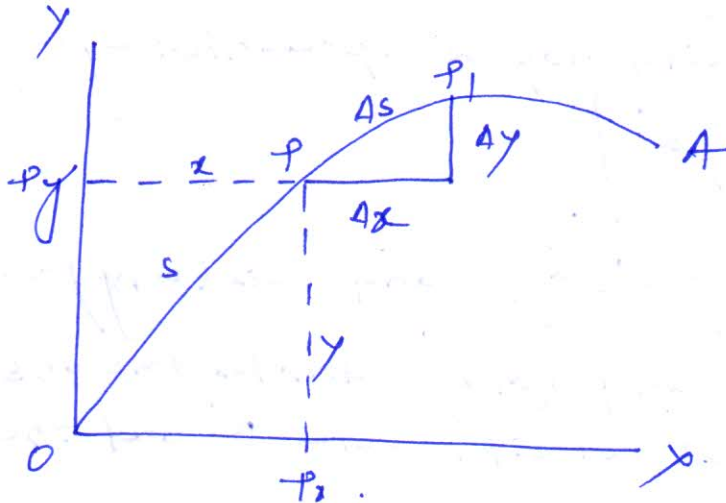

Consider a particle P in a plane on a curved path. To define the particle we need two coordinates x and y as the particle moves, these coordinates ~~move~~

change with time and the displacement time equations are

$$x = f_1(t) \quad y = f_2(t) \quad \text{--- (1)}$$

The motion of particle can also be expressed as

$$y = f(x) \quad s = f_1(t)$$

where $y = f(x)$ represents the equation of path of A and $s = f_1(t)$ gives displacement s measured along the path as a function of time.

Velocity :-

Considering an infinitesimal time difference from t to t + Δt during which the particle moves from P to P', along its path.

then velocity of particle may be expressed as

$$\boxed{\bar{V}_{av} = \frac{AS}{\Delta t}}$$

$$\boxed{\begin{aligned} (V_{av})_x &= \frac{\Delta x}{\Delta t} \\ (V_{av})_y &= \frac{\Delta y}{\Delta t} \end{aligned}}$$

(average velocity along x and y coordinates)

It can also be expressed as <https://civinnovate.com/civil-engineering-notes/>

$$v_x = \frac{dx}{dt} = \dot{x}$$

$$v_y = \frac{dy}{dt} = \dot{y}$$

So the total velocity may be represented by

$$v = \sqrt{\dot{x}^2 + \dot{y}^2}$$

$$\text{and } \cos(\theta, x) = \frac{\dot{x}}{v} \quad \text{and } \cos(\theta, y) = \frac{\dot{y}}{v}$$

where $\theta(\theta, x)$ and (θ, y) denotes the angles betⁿ the direction of velocity vector \vec{v} and the coordinate axes.

Acceleration :-

The acceleration particles may be described as

$$a_x = \frac{dv_x}{dt} = \ddot{x}$$
$$a_y = \frac{dv_y}{dt} = \ddot{y}$$

It is also known as instantaneous acceleration

$$\text{Total acceleration } a = \sqrt{\ddot{x}^2 + \ddot{y}^2}$$

Considering particular path for above case.

$$x = r \cos \omega t \quad y = r \sin \omega t.$$

$$x^2 + y^2 = r^2$$

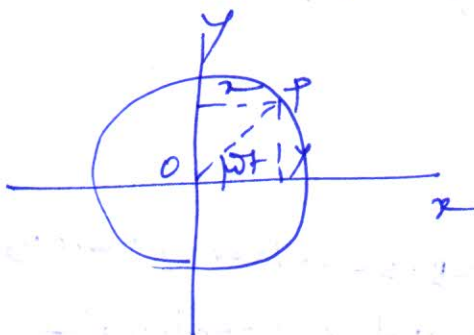

$$\dot{x} = -r\omega \sin \omega t \quad \dot{y} = r\omega \cos \omega t$$

$$v = \sqrt{\dot{x}^2 + \dot{y}^2}$$

$$\ddot{x} = -r\omega^2 \cos \omega t \quad \ddot{y} = -r\omega^2 \sin \omega t$$

$$a = \sqrt{\ddot{x}^2 + \ddot{y}^2}$$

D'Alembert's Principle in Curvilinear Motion

Acceleration during curvilinear motion

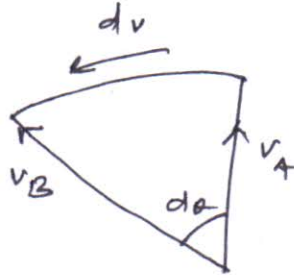
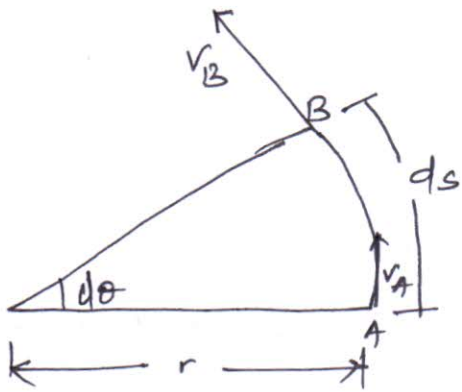

$v_A = \text{tangential velocity at A}$
 $= \text{tangential velocity at B}$
 $= v_B = v$

Now $dv = v d\theta = v \frac{ds}{r} = \frac{v}{r} ds$

acceleration = $\frac{dv}{dt} = \frac{v^2}{r}$

so when a body moves with uniform velocity v along a curved path of radius r , it has a radial inward acceleration of magnitude $\frac{v^2}{r}$

Applying D'Alembert's principle to set equilibrium condition an inertia force of magnitude $\frac{W}{g} a$ = $\frac{W}{g} \frac{v^2}{r}$ must be applied in outward direction it is known as centrifugal force.

Motion on a level road

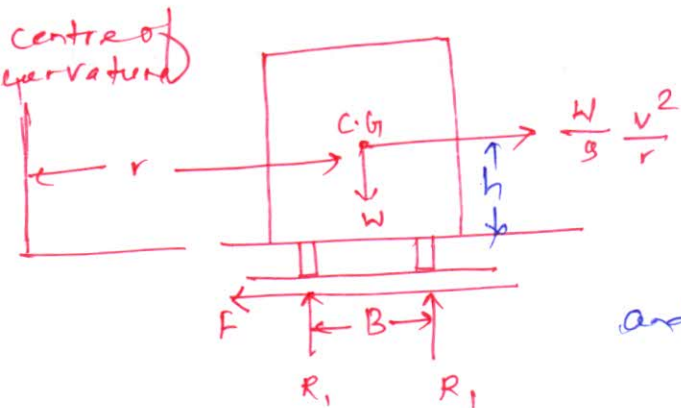

Consider a body is moving with uniform velocity on a curvilinear curve of radius r . Let the road is flat.

Let $W = \text{wt. of the body}$ and inertia force is given by

$$\frac{W}{g} a = \frac{W}{g} \frac{v^2}{r}$$

Condition for skidding

Let W = wt. of vehicle

R_1, R_2 = reactions at wheel

F = frictional force.

$\frac{W}{g} \cdot \frac{v^2}{r}$ = inertia force

Skidding takes place when the frictional force reaches limiting value i.e

$$F = \mu W$$

Then maximum permissible speed to avoid skidding

$$v = \sqrt{\frac{gr}{2} \frac{B}{h}}$$

The distance betn inner and outer wheel is equal to the gauge of railway track and expressed as G .

so

$$v = \sqrt{\frac{gr}{2} \frac{G}{h}}$$

Designed speed and angle of Braking

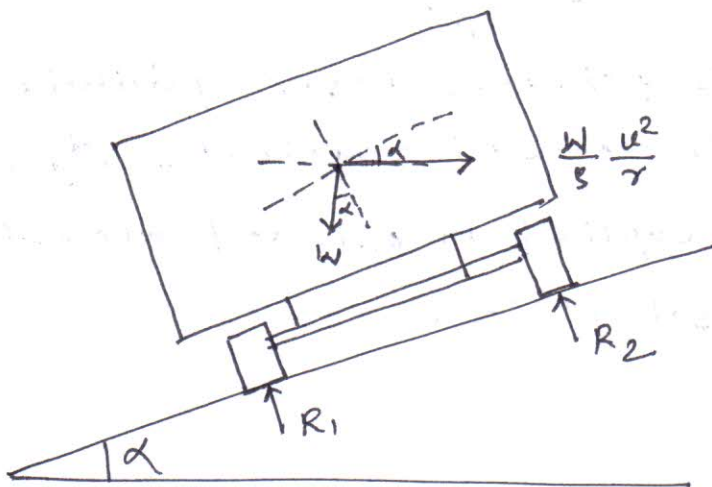

Σ of all the forces in the inclined plane

$$\frac{W}{g} \frac{v^2}{r} \cos \alpha - W \sin \alpha = 0$$

$$\Rightarrow \tan \alpha = \frac{v^2}{gr}$$

Relation betn the angle of braking and designed speed

is $\tan \alpha = \frac{v^2}{gr}$

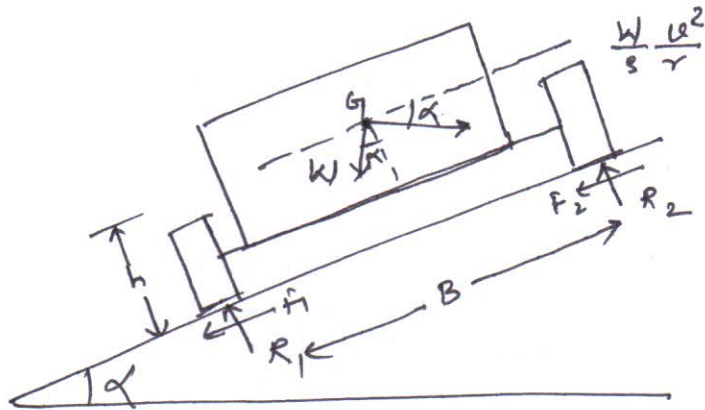

(a) condition for skidding

$$v = \sqrt{\tan(\alpha + \phi) \times g r}$$

where α = angle of inclination

$$\tan \phi = \mu$$

g = ~~effective~~ gravitational acceleration

r = radius of curve

~~then~~ the vehicle will skid if the velocity is more than this value.

(b) condition for overturning!

Limiting speed from consideration of overturning

$$v = \sqrt{g \frac{G + (2he/G)}{2h - e}}$$

Q.1

A circular ring has a mean radius $r = 500 \text{ mm}$ and is made of steel for which $w = 77.12 \text{ kN/m}^3$ and for which ultimate strength in tension is 413.25 MPa . Find the uniform speed of rotation about its geometrical axis perpendicular to the plane of the ring at which it will burst?

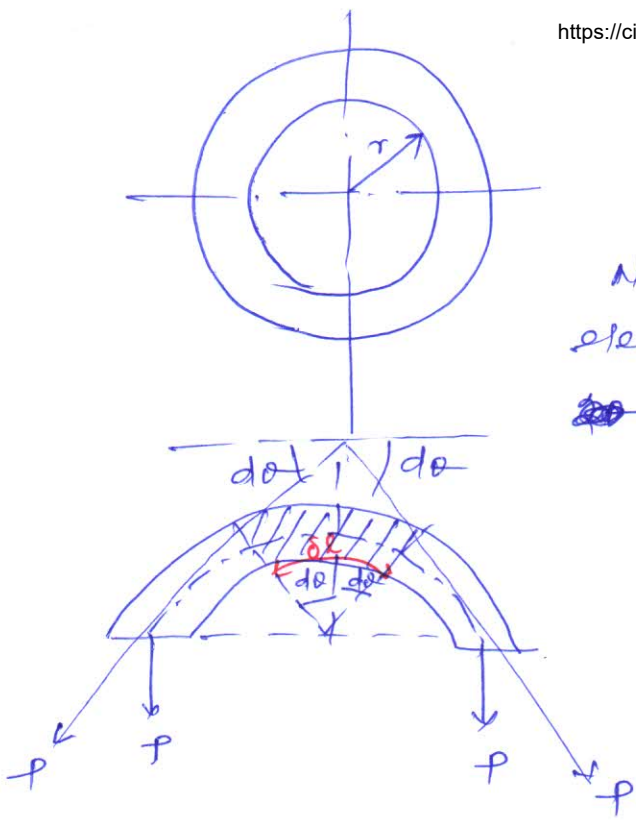

mean radius \$r = 500 \text{ mm} = 0.5 \text{ m}\$,

density of the wheel \$w = 77.12 \text{ kN/m}^3\$

\$\sigma_t = \text{ultimate strength} = 413.85 \times 10^6 \text{ Pa}\$

Now considering an infinitesimal small elementary ring extruded at an angle of \$2d\theta\$

centrifugal force acting

$$F_c = \frac{dw}{g} \cdot \frac{v^2}{r}$$

Let \$P = \text{tension on the ring}\$

\$A = \text{cross-sectional area of ring}\$

\$dw = \text{wt. of the element}\$

$$= w \times \text{volume}$$

$$= w \times A \times dr$$

$$= w \times A \times r \times 2d\theta$$

Now centrifugal force

$$\frac{w}{g} (A dr) \times \frac{v^2}{r} = \frac{w}{g} \times A \times r \times 2d\theta \times \frac{v^2}{r} = \frac{2wA dr v^2}{g}$$

Balancing forces along the radius \$= 2P \sin d\theta\$

$$= \frac{2wA dr v^2}{g} \quad \text{--- (1)}$$

as \$d\theta\$ is very small \$\sin d\theta \approx d\theta\$

Eq. (1) may be written as

$$2P d\theta = \frac{2wA dr v^2}{g}$$

$$\Rightarrow \boxed{P = \frac{wA r v^2}{g}} \quad \text{--- (2)}$$

Tensile stress on the ring \$\sigma_t = \frac{P}{A} = \frac{w r v^2}{g}\$

Now substituting the values

$$413.85 \times 10^6 = \frac{77.12 \times 10^3 \times v^2}{9.81} \Rightarrow v = 229.45 \text{ m/s}$$

$$\text{Now } v = \frac{\pi D N}{60} \Rightarrow N = \frac{60 \times 229.45}{\pi \times 1} = \boxed{4382 \text{ rpm}}$$

D) D'Alembert's Principle, Curvilinear Motion

3

Equation of motion of a particle may be written as

$$\left. \begin{aligned} X - m\ddot{x} &= 0 \\ Y - m\ddot{y} &= 0 \end{aligned} \right\} \text{--- (1)}$$

Ex

Find the proper super elevation 'e' for a 7.2 m highway curve of radius $r = 600\text{m}$ in order that a car travelling with a speed of 80 kmph will have no tendency to skid sideways.

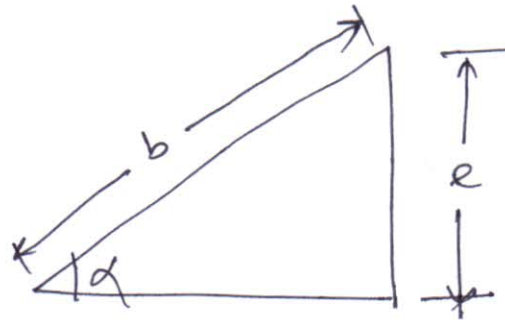
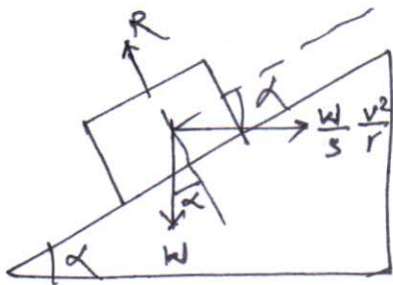

$$b = 7.2\text{m} \quad r = 600\text{m} \quad v = 80\text{kmph} = 22.23\text{ m/s}$$

Resolving along the inclined plane

$$W \sin \alpha = \frac{W}{g} \cdot \frac{v^2}{r} \cos \alpha$$

$$\Rightarrow \tan \alpha = \frac{v^2}{rg}$$

from the geometry $\sin \alpha = \frac{e}{b}$, since α is very small

let $\sin \alpha \approx \tan \alpha$

$$\frac{v^2}{rg} = \frac{e}{b} \Rightarrow e = \frac{bv^2}{rg} = \frac{7.2 \times 22.23^2}{600 \times 9.81}$$

$$= 0.604\text{m} \quad (\text{Ans})$$

Q.3

A racing car travels around a circular track of 300m radius with a speed of 884 kmph. What angle α should the floor of the track make with horizontal in order to safeguard against skidding.

velocity $v = 884 \text{ kmph}$ $r = 300 \text{ m}$
 $= 106.67 \text{ m/s}$

We have angle of banking $\tan \alpha = \frac{v^2}{rg}$

$\therefore \alpha = \tan^{-1} \left(\frac{106.67^2}{300 \times 9.81} \right) = \boxed{75.5^\circ} \text{ (Ans)}$

Q.4

Two balls of wt $W_A = 44.5 \text{ N}$ and $W_B = 66.75 \text{ N}$ are connected by an elastic string and supported on a turntable as shown. When the turntable is at rest, the tension in the string is $S = 222.5 \text{ N}$ and the balls exert this same force on each of the stops A and B. What forces will they exert on the stops when the turntable is rotating uniformly about the vertical axis CD at 60 rpm?

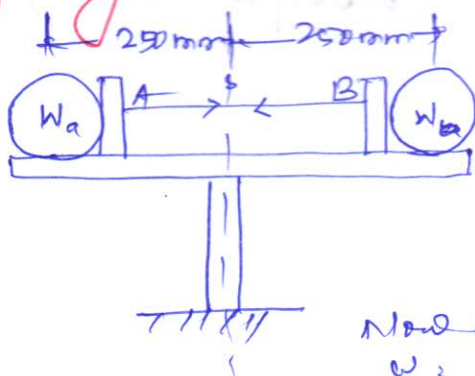

We have;

$W_A = 44.5 \text{ N}$ $W_B = 66.75 \text{ N}$

$S = 222.5 \text{ N}$

$\omega = 60 \text{ rpm}$,

radius of rotation $r_1, r_2 = 0.25 \text{ m}$

Now angular velocity
 $\omega = \frac{2\pi N}{60} = \frac{2\pi \times 60}{60} = 2\pi \text{ rad/s}$

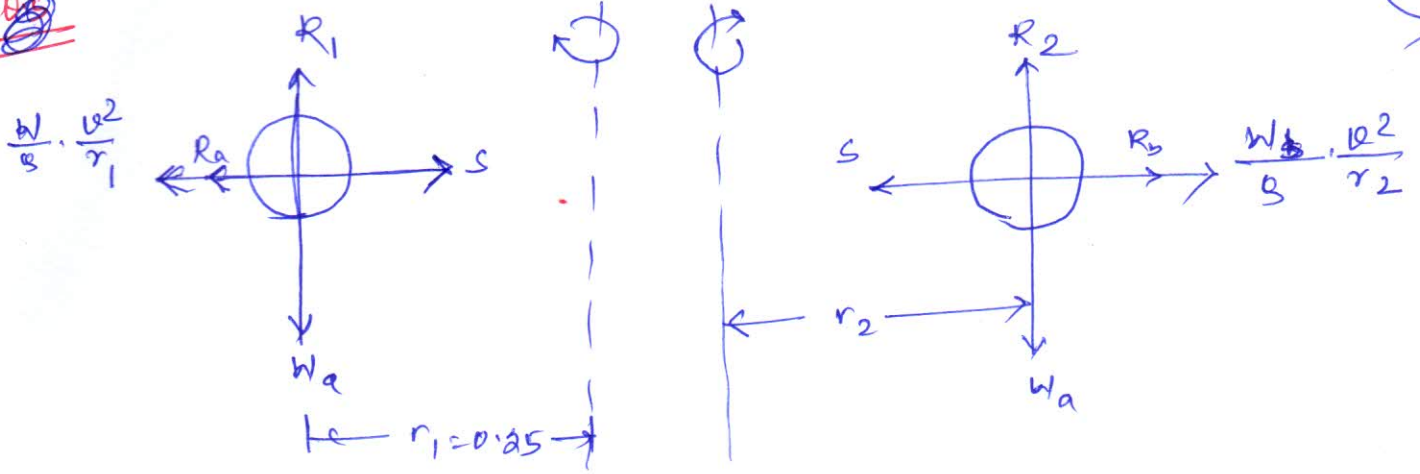

~~considering~~ considering the left hand side ball

$$R_a + \frac{W_a}{s} \cdot r_1 \cdot w^2 = S$$

$$\Rightarrow R_a = 222.5 - \frac{44.5 \times 0.25 \times (2\pi)^2}{9.81}$$

$$= \boxed{177.72 \text{ N.}}$$

Considering the ball on right hand side

$$R_b + \frac{W_b}{s} \times r_2 \times w^2 = S$$

$$\Rightarrow R_b = 222.5 - \frac{66.75 \times 0.25 \times (2\pi)^2}{9.81}$$

$$= \boxed{155.39 \text{ N.}}$$

Rotation of Rigid Bodies!

<https://civinnovate.com/civil-engineering-notes/>



Angular motion!

The rate of change of angular displacement with time is called angular velocity and denoted by ω .

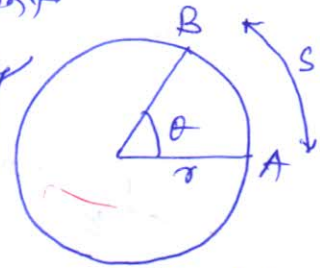

(Fig-1)

$$\boxed{\omega = \frac{d\theta}{dt}} \quad \text{--- (1)}$$

The rate of change of angular velocity with time is called angular acceleration and denoted by α

$$\boxed{\alpha = \frac{d\omega}{dt} = \frac{d^2\theta}{dt^2}} \quad \text{--- (2)}$$

Angular acceleration may also be represented as:

$$\alpha = \frac{d\omega}{dt} = \frac{d\omega}{d\theta} \cdot \frac{d\theta}{dt}$$

$$\Rightarrow \boxed{\alpha = \omega \cdot \frac{d\omega}{d\theta}} \quad \text{--- (3)} \quad \left(\because \frac{d\theta}{dt} = \omega \right)$$

Relationship between angular motion and linear motion

from fig-1 $s = r\theta$

tangential velocity (linear) of the particle is

$$\boxed{v = \frac{ds}{dt} = r \cdot \frac{d\theta}{dt}} \quad \text{--- (4)}$$

$$\text{linear acceleration} \quad \boxed{a_t = \frac{dv}{dt} = r \frac{d^2\theta}{dt^2}} \quad \text{--- (5)}$$

If $\frac{v^2}{r} =$ radial acceleration

$$\text{Then } \boxed{a_n = \frac{v^2}{r} = r\omega^2} \quad \text{--- (6)} \quad \text{where } a_n = \text{radial acceleration}$$

uniform angular velocity (ω)

$$\boxed{\omega = \frac{2\pi N}{60} \text{ rad/sec}} \quad \text{--- (7)}$$

Q.11 The step pulley starts from rest and accelerated at 2 rad/s^2 . How much time is required for block A to move 20m. find also the velocity of A and B at that time.

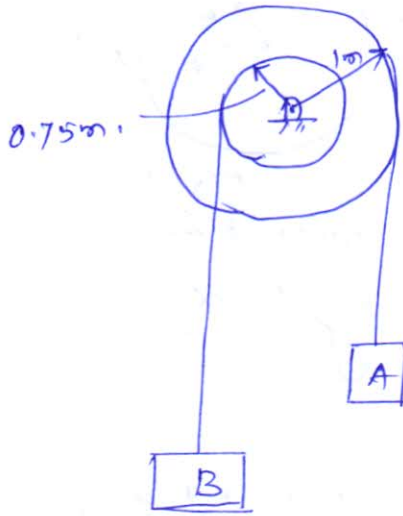

when A moves by 20m, the angular displacement of pulley θ is given by

$$r\theta = s$$

$$\Rightarrow 1 \times \theta = 20$$

$$\Rightarrow \boxed{\theta = 20 \text{ rad}}$$

$\alpha = 2 \text{ rad/s}^2$ and $\omega_0 = 0$
from kinematic relation,

$$\theta = \omega_0 t + \frac{1}{2} \alpha t^2$$

$$\Rightarrow 20 = 0 \times t + \frac{1}{2} \times 2 \times t^2$$

$$\Rightarrow \boxed{t = 4.472 \text{ sec.}}$$

velocity of pulley at this time

$$\omega = \omega_0 + \alpha t$$

$$= 0 + 2 \times 4.472$$

$$= \boxed{8.944 \text{ rad/s}}$$

velocity of block A $v_A = 1 \times 8.944$

$$= \boxed{8.944 \text{ m/s}}$$

velocity of block B $v_B = 0.75 \times 8.944$

$$= \boxed{6.708 \text{ m/s.}}$$

Kinematics of rigid body for rotation:-

consider a wheel rotating about its axis in clockwise direction with an acceleration α . Let δm be mass of an element at a distance r from the axis of rotation. If θ be the

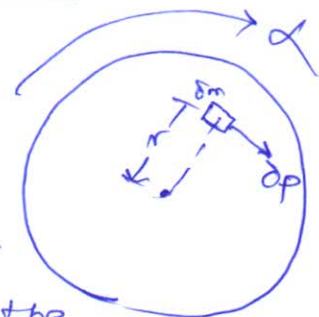

resulting force on this element <https://civinnovate.com/civil-engineering-notes/>

$$\delta p = \delta m \times a \quad (a = \text{tangential acceleration})$$

$$\text{but } a = r \times \alpha \quad (\alpha = \text{angular acceleration})$$

$$\therefore \boxed{\delta p = \delta m r \alpha}$$

Rotational moment $\delta M_t = \delta p \times r$

$$= \delta m r^2 \alpha$$

$$M_t = \sum \delta M_t = \sum \delta m r^2 \alpha$$

$$= \alpha \sum \delta m r^2$$

$$= \alpha I$$

$$\Rightarrow \boxed{M_t = \alpha I} \quad (I = \text{mass moment of inertia})$$

Product of mass moment of inertia and angular velocity of rotating body is called angular momentum

so $\boxed{\text{Angular momentum} = I \omega}$

Kinetic energy of rotating bodies

$$\boxed{K.E = \frac{1}{2} I \omega^2}$$

Q.2

A flywheel weighing 50kN and having radius of gyration 1m loses its speed from 400 rpm to 280 rpm in 2min. Calculate

(a) retarding torque, (b) change in KE during the period, (c) change in angular momentum.

we have $\omega_0 = 400 \text{ rpm} = \frac{2\pi \times 400}{60} = 41.89 \text{ rad/s}$

$$\omega = 280 \text{ rpm} = \frac{2\pi \times 280}{60} = 29.32 \text{ rad/s}$$

$$t = 2 \text{ min} = 120 \text{ sec}$$

$$\omega = \omega_0 + \alpha t$$

$$\Rightarrow \alpha = \frac{\omega - \omega_0}{t} = \boxed{-1.047 \text{ rad/s}^2}$$

Wt of flywheel = 50000 N

mass of " = $\frac{50000}{9.81} = 5096.84 \text{ kg}$

Radius of gyration $k = 1 \text{ m}$

$I = mk^2$

$= 5096.84 \times 1 = 5096.84$

(a) Retarding torque

$L\alpha = 5096.84 \times 0.11047$

$= \boxed{533.64 \text{ Nm}}$

(b) change in KE

$= \text{initial KE} - \text{final KE}$

$= \frac{1}{2} I\omega_0^2 - \frac{1}{2} I\omega^2$

$= \frac{1}{2} \times 5096.84 (41.89^2 - 29.32^2)$

$= \boxed{\cancel{2280442.9} \text{ Nm}} \quad \boxed{2281115.462 \text{ Nm}}$

(c) change in angular momentum

$I\omega_0 - I\omega$

$= 5096.84 (41.89 - 29.32)$

$= \boxed{64067.298 \text{ Nm}}$

Q3

A cylinder weighing 500N is welded to a 1m long uniform bar of 200N. Determine the acceleration with which the assembly will rotate about point A, if released from rest in horizontal position. Determine the reactions at A at this instant.

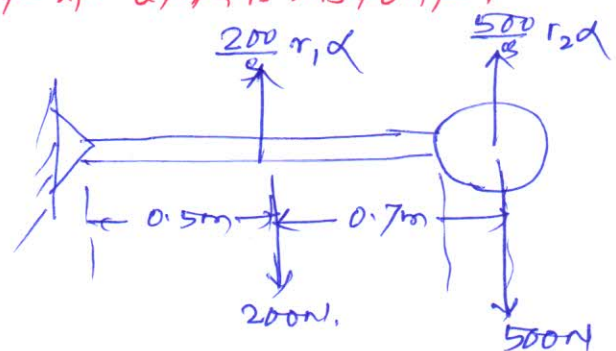
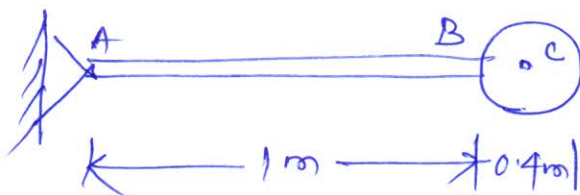

Let α = angular acceleration of the assembly (3)

I = mass moment of inertia of the assembly

$$I = I_G + Md^2 \quad (\text{transfer formula})$$

$$\text{mass } ML^2 \text{ of bar about } A = \frac{1}{2} \times \frac{200}{9.81} \times 1^2 + \frac{200}{9.81} \times (0.5)^2$$
$$= 6.7968$$

mass ML^2 of cylinder about A

$$= \frac{1}{2} \times \frac{500}{9.81} \times 0.2^2 + \frac{500}{9.81} \times 1.2^2$$
$$= 74.4$$

$$ML^2 \text{ of the system} = 6.7968 + 74.4 = 81.2097$$

Rotational moment about A

$$M_A = 200 \times 0.5 + 500 \times 1.2 = 700 \text{ Nm}$$

$$M_A = I\alpha$$

$$\Rightarrow \alpha = \frac{700}{81.2097} = \boxed{8.6197} \text{ rad/sec}$$

Instantaneous acceleration of rod AB is

$$\text{vertical and } = r_1 \alpha = 0.5 \times 8.6197$$
$$= 4.31 \text{ m/s}.$$

Similarly instantaneous acceleration of cylinder

$$= r_2 \alpha = 1.2 \times 8.6197$$
$$= 10.34 \text{ m/s}.$$

Applying D'Alembert's dynamic equilibrium

$$R_A = 200 + 500 - \frac{200}{9.81} \times 4.31 - \frac{500}{9.81} \times 10.34 \uparrow$$

$$\Rightarrow \boxed{R_A = 84.93 \text{ N.}} \quad (\text{Ans})$$