



# Civinnovate

Discover, Learn, and Innovate in Civil Engineering

# 3

# Theory of Structures

**W M Jenkins BSc, PhD, CEng, FICE, FStructE**  
**Emeritus Professor of Civil Engineering,**  
**School of Engineering, The Hatfield Polytechnic**

## Contents

3.1	Introduction	3/3	3.6	Influence lines	3/19
3.1.1	Basic concepts	3/3	3.6.1	Introduction and definitions	3/19
3.1.2	Force-displacement relationships	3/3	3.6.2	Influence lines for beams	3/19
3.1.3	Static and kinetic determinacy	3/4	3.6.3	Influence lines for plane trusses	3/20
3.2	Statically determinate truss analysis	3/4	3.6.4	Influence lines for statically indeterminate structures	3/20
3.2.1	Introduction	3/4	3.6.5	Maxwell's reciprocal theorem	3/21
3.2.2	Methods of analysis	3/5	3.6.6	Mueller-Breslau's principle	3/21
3.2.3	Method of tension coefficients	3/5	3.6.7	Application to model analysis	3/21
3.3	The flexibility method	3/6	3.6.8	Use of the computer in obtaining influence lines	3/22
3.3.1	Introduction	3/6	3.7	Structural dynamics	3/23
3.3.2	Evaluation of flexibility coefficients	3/7	3.7.1	Introduction and definitions	3/23
3.3.3	Application to beam and rigid frame analysis	3/8	3.7.2	Single degree of freedom vibrations	3/23
3.3.4	Application to truss analysis	3/10	3.7.3	Multi-degree of freedom vibrations	3/25
3.3.5	Comments on the flexibility method	3/10	3.8	Plastic analysts	3/26
3.4	The stiffness method	3/11	3.8.1	Introduction	3/26
3.4.1	Introduction	3/11	3.8.2	Theorems and principles	3/27
3.4.2	Member stiffness matrix	3/11	3.8.3	Examples of plastic analysis	3/28
3.4.3	Assembly of structure stiffness matrix	3/12	References		3/31
3.4.4	Stiffness transformations	3/13	Bibliography		3/31
3.4.5	Some aspects of computerization of the stiffness method	3/13			
3.4.6	Finite element analysis	3/14			
3.5	Moment distribution	3/16			
3.5.1	Introduction	3/16			
3.5.2	Distribution factors, carry-over factors and fixed-end moments	3/16			
3.5.3	Moment distribution without sway	3/17			
3.5.4	Moment distribution with sway	3/18			
3.5.5	Additional topics in moment distribution	3/18			

### 3.1 Introduction

#### 3.1.1 Basic concepts

The 'Theory of Structures' is concerned with establishing an understanding of the behaviour of structures such as beams, columns, frames, plates and shells, when subjected to applied loads or other actions which have the effect of changing the state of stress and deformation of the structure. The process of 'structural analysis' applies the principles established by the Theory of Structures, to analyse a given structure under specified loading and possibly other disturbances such as temperature variation or movement of supports. The drawing of a bending moment diagram for a beam is an act of structural analysis which requires a knowledge of structural theory in order to relate the applied loads, reactive forces and dimensions to actual values of bending moment in the beam. Hence 'theory' and 'analysis' are closely related and in general the term 'theory' is intended to include 'analysis'.

Two aspects of structural behaviour are of paramount importance. If the internal stress distribution in a structural member is examined it is possible, by integration, to describe the situation in terms of 'stress resultants'. In the general three-dimensional situation, these are six in number: two bending moments, two shear forces, a twisting moment and a thrust. Conversely, it is, of course, possible to work the other way and convert stress-resultant actions (forces) into stress distributions. The second aspect is that of deformation. It is not usually necessary to describe structural deformation in continuous terms throughout the structure and it is usually sufficient to consider values of displacement at selected discrete points, usually the joints, of the structure.

At certain points in a structure, the continuity of a member, or between members, may be interrupted by a 'release'. This is a device which imposes a zero value on one of the stress resultants. A hinge is a familiar example of a release. Releases may exist as mechanical devices in the real structure or may be introduced, in imagination, in a structure under analysis.

In carrying out a structural analysis it is generally convenient to describe the state of stress or deformation in terms of forces and displacements at selected points, termed 'nodes'. These are usually the ends of members, or the joints and this approach introduces the idea of a structural element such as a beam or column. A knowledge of the forces or displacements at the nodes of a structural element is sufficient to define the complete state of stress or deformation within the element providing the relationships between forces and displacements are established. The establishment of such relationships lies within the province of the theory of structures.

Corresponding to the basic concepts of force and displacement, there are two important physical principles which must be satisfied in a structural analysis. The structure as a whole, and every part of it, must be in equilibrium under the actions of the force system. If, for example, we imagine an element, perhaps a beam, to be removed from a structure by cutting through the ends, the internal stress resultants may now be thought of as external forces and the element must be in equilibrium under the combined action of these forces and any applied loads. In general, six independent conditions of equilibrium exist; zero sums of forces in three perpendicular directions, and zero sums of moments about three perpendicular axes. The second principle is termed 'compatibility'. This states that the component parts of a structure must deform in a compatible way, i.e. the parts must fit together without discontinuity at all stages of the loading. Since a release will allow a discontinuity to develop, its introduction will reduce the total number of compatibility conditions by one.

#### 3.1.2 Force-displacement relationships

A simple beam element AB is shown in Figure 3.1. The application of end moments  $M_A$  and  $M_B$  produces a shear force  $Q$  throughout the beam, and end rotations  $\theta_A$  and  $\theta_B$ . By the stiffness method (see page 3/11), it may be shown that the end moments and rotations are related as follows:

$$\left. \begin{aligned} M_A &= \frac{4EI\theta_A}{l} + \frac{2EI\theta_B}{l} \\ M_B &= \frac{4EI\theta_B}{l} + \frac{2EI\theta_A}{l} \end{aligned} \right\} \quad (3.1)$$

Or, in matrix notation,

$$\begin{bmatrix} M_A \\ M_B \end{bmatrix} = \frac{2EI}{l} \begin{bmatrix} 2 & 1 \\ 1 & 2 \end{bmatrix} \begin{bmatrix} \theta_A \\ \theta_B \end{bmatrix}$$

which may be abbreviated to,

$$S = k\theta \quad (3.2)$$

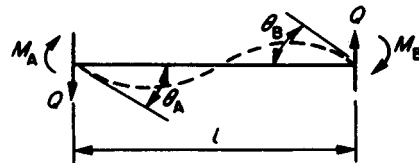

Figure 3.1

Equation (3.2) expresses the force-displacement relationships for the beam element of Figure 3.1. The matrices  $S$  and  $\theta$  contain the end 'forces' and displacements respectively. The matrix  $k$  is the *stiffness matrix* of the element since it contains end forces corresponding to *unit* values of the end rotations.

The relationships of Equation (3.2) may be expressed in the inverse form:

$$\begin{bmatrix} \theta_A \\ \theta_B \end{bmatrix} = \frac{l}{6EI} \begin{bmatrix} 2 & -1 \\ -1 & 2 \end{bmatrix} \begin{bmatrix} M_A \\ M_B \end{bmatrix}$$

or

$$\theta = fS \quad (3.3)$$

Here the matrix  $f$  is the *flexibility matrix* of the element since it expresses the end displacements corresponding to *unit* values of the end forces.

It should be noted that an inverse relationship exists between  $k$  and  $f$

i.e.

$$kf = I$$

or,

$$k = f^{-1} \quad (3.4)$$

or,

$$f = k^{-1}$$

### 3/4 Theory of structures

The establishment of force–displacement relationships for structural elements in the form of Equations (3.2) or (3.3) is an important part of the process of structural analysis since the element properties may then be incorporated in the formulation of a mathematical model of the structure.

#### 3.1.3 Static and kinematic determinacy

If the compatibility conditions for a structure are progressively reduced in number by the introduction of releases, there is reached a state at which the introduction of *one further* release would convert the structure into a mechanism. In this state the structure is *statically determinate* and the nodal forces may be calculated directly from the equilibrium conditions. If the releases are now removed, restoring the structure to its correct condition, nodal forces will be introduced which cannot be determined solely from equilibrium considerations. The structure is *statically indeterminate* and compatibility conditions are necessary to effect a solution.

The structure shown in Figure 3.2(a) is hinged to rigid foundations at A, C and D. The continuity through the foundations is indicated by the (imaginary) members, AD and CD. If the releases at A, C and D are removed, the structure is as shown in Figure 3.2(b) which is seen to consist of two closed rings. Cutting through the rings as shown in Figure 3.2(c) produces a series of simple cantilevers which are statically determinate. The number of stress resultants released by each cut would be three in the case of a planar structure, six in the case of a space structure. Thus, the degree of static indeterminacy is 3 or 6 times the number of rings. It follows that the structure shown in Figure 3.2(b) is 6 times statically indeterminate whereas the structure of Figure 3.2(a), since releases are introduced at A, C and D, is 3 times statically indeterminate. A general relationship between the number of members  $m$ , number of nodes  $n$ , and degree of static indeterminacy  $n_s$ , may be obtained as follows:

$$n_s = \frac{6}{3}(m - n + 1) - r \tag{3.5}$$

where  $r$  is the number of releases in the actual structure

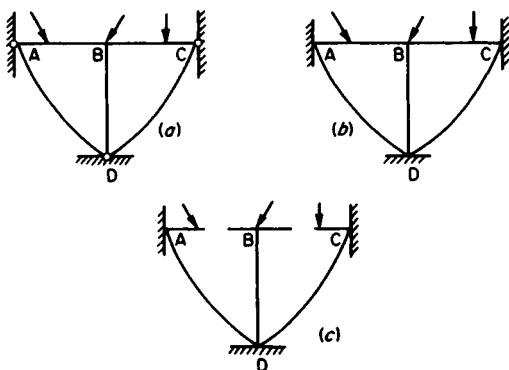

Figure 3.2

Turning now to the question of *kinematical determinacy*; a structure is defined as kinematically determinate if it is possible to obtain the nodal displacements from compatibility conditions without reference to equilibrium conditions. Thus a fixed-end beam is kinematically determinate since the end rotations are known from the compatibility conditions of the supports.

Again, consider the structure shown in Figure 3.2(b). The

structure is kinematically determinate except for the displacements of joint B. If the members are considered to have infinitely large extensional rigidities, then the rotation at B is the only unknown nodal displacement. The degree of kinematical indeterminacy is therefore 1. The displacements at B are *constrained* by the assumption of zero vertical and horizontal displacements. A *constraint* is defined as a device which constrains a displacement at a certain node to be the same as the corresponding displacement, usually zero, at another node. Reverting to the structure of Figure 3.2(a), it is seen that three constraints, have been removed by the introduction of hinges (releases) at A, C and D. Thus rotational displacements can develop at these nodes and the degree of kinematical indeterminacy is increased from 1 to 4.

A general relationship between the numbers of nodes  $n$ , constraints  $c$ , releases  $r$ , and the degree of kinematical indeterminacy  $n_k$  is as follows,

$$n_k = \frac{6}{3}(n - 1) - c + r \tag{3.6}$$

The coefficient 6 is taken in three-dimensional cases and the coefficient 3 in two-dimensional cases. It should now be apparent that the modern approach to structural theory has developed in a highly organised way. This has been dictated by the development of computer-orientated methods which have required a re-assessment of basic principles and their application in the process of analysis. These ideas will be further developed in some of the following sections.

## 3.2 Statically determinate truss analysis

### 3.2.1 Introduction

A structural frame is a system of bars connected by joints. The joints may be, ideally, *pinned* or *rigid*, although in practice the performance of a real joint may lie somewhere between these two extremes. A *truss* is generally considered to be a frame with pinned joints, and if such a frame is loaded only at the joints, then the members carry axial tensions or compressions. *Plane* trusses will resist deformation due to loads acting in the plane of the truss only, whereas *space* trusses can resist loads acting in any direction.

Under load, the members of a truss will change length slightly and the geometry of the frame is thus altered. The effect of such alteration in geometry is generally negligible in the analysis.

The question of statical determinacy has been mentioned in the previous section where a relationship, Equation (3.5) was stated from which the degree of statical indeterminacy could be determined. Although this relationship is of general application, in the case of plane and space trusses, a simpler relationship may be established.

The simplest plane frame is a triangle of three members and three joints. The addition of a fourth joint, in the plane of the triangle, will require two additional members. Thus in a frame having  $j$  joints, the number of members is:

$$n = 2(j - 3) + 3 = 2j - 3 \tag{3.7}$$

A truss with this number of members is statically determinate, providing the truss is supported in a statically determinate way. Statically determinate trusses have two important properties. They cannot be altered in shape without altering the length of one or more members, and, secondly, any member may be altered in length without inducing stresses in the truss, i.e. the

truss cannot be *self stressed* due to imperfect lengths of members or differential temperature change.

The simplest space truss is in the shape of a tetrahedron with four joints and six members. Each additional joint will require three more members for connection with the tetrahedron, and thus:

$$n = 3(j - 4) + 6 = 3j - 6 \quad (3.8)$$

A space truss with this number of members is statically determinate, again providing the support system is itself statically determinate. It should be noted that in the assessment of the statical determinacy of a truss, member forces and reactive forces should all be considered when counting the number of unknowns. Since equilibrium conditions will provide two relationships at each joint in a plane truss (there is a space truss), the simplest approach is to find the total number of unknowns, member forces and reactive components, and compare this with 2 or 3 times the number of joints.

### 3.2.2 Methods of analysis

Only brief mention will be made here of the methods of statically determinate analysis of trusses. For a more detailed treatment the reader is referred to Jenkins<sup>1</sup> and Coates, Coutie and Kong.<sup>2</sup>

The *force diagram* method is a graphical solution in which a vector polygon of forces is drawn to scale proceeding from joint to joint. It is necessary to have not more than two unknown forces at any joint, but this requirement can be met with a judicious choice of order. The two conditions of overall equilibrium of the plane structure imply that the force vector polygon will form a closed figure. The method is particularly suitable for trusses with a difficult geometry where it is convenient to work to a scale drawing of the outline of the truss.

The method of *resolution at joints* is suitable for a complete analysis of a truss. The reactions are determined and then, proceeding from joint to joint, the vertical and horizontal equilibrium conditions are set down in terms of the member forces. Since two equations will result at each joint in a plane truss, it is possible to determine not more than two forces for each pair of equations. As an illustration of the method, consider the plane truss shown in Figure 3.3. The truss is symmetrically loaded and the reactions are clearly 15 kN each.

Consider the equilibrium of joint A,

vertically,  $P_{AE} \cos 45^\circ = R_A$ ; hence  $P_{AE} = 15\sqrt{2}$  kN (compression)

horizontally,  $P_{AC} = P_{AE} \cos 45^\circ$ ; hence  $P_{AC} = 15$  kN (tension)

It should be noted that the arrows drawn on the members in Figure 3.3 indicate the directions of forces acting *on the joints*. It is also seen that the directions of the arrows at joint A, for example, are consistent with equilibrium of the joint. Proceeding to joint C it is clear that  $P_{CE} = 10$  kN (tension), and that  $P_{CD} = P_{AC} = 15$  kN (tension). The remainder of the solution may be obtained by resolving forces at joint E, from which  $P_{ED} = 5\sqrt{2}$  kN (tension) and  $P_{EF} = 20$  kN (compression).

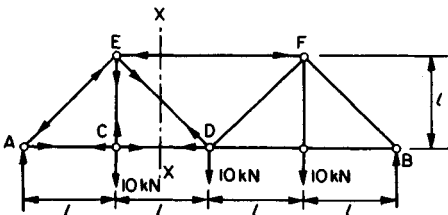

Figure 3.3

The *method of sections* is useful when it is required to determine forces in a limited number of the members of a truss. Consider, for example, the member ED of the truss in Figure 3.3. Imagine a cut to be made along the line XX and consider the vertical equilibrium of the part to the left of XX. The vertical forces acting are  $R_A$ , the 10 kN load at C and the vertical component of the force in ED. The equation of vertical equilibrium is:

$$15 - 10 = P_{ED} \cos 45^\circ \quad \text{hence } P_{ED} = 5\sqrt{2} \text{ kN}$$

Since a downwards arrow on the left-hand part of ED is required for equilibrium, it follows that the member is in tension. The method of tension coefficients is particularly suitable for the analysis of space frames and will be outlined in the following section.

### 3.2.3 Method of tension coefficients

The method is based on the idea of systematic resolution of forces at joints. In Figure 3.4, let AB be any member in a plane truss,  $T_{AB}$  = force in member (tension positive), and  $L_{AB}$  = length of member.

We define:

$$T_{AB} = L_{AB} t_{AB} \quad (3.9)$$

where  $t_{AB}$  = tension coefficient.

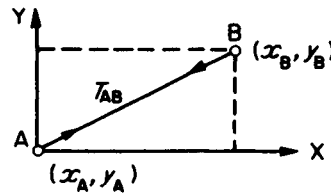

Figure 3.4

That is, the tension coefficient is the actual force in the member divided by the length of the member. Now, at A, the component of  $T_{AB}$  in the X-direction:

$$= T_{AB} \cos \text{BAX}$$

$$= T_{AB} \frac{(x_B - x_A)}{L_{AB}} = t_{AB}(x_B - x_A)$$

Similarly the component of  $T_{AB}$  in the Y-direction:

$$= t_{AB}(y_B - y_A)$$

At the other end of the member the components are:

$$t_{AB}(x_A - x_B), t_{AB}(y_A - y_B)$$

If at A the external forces have components  $X_A$  and  $Y_A$ , and if there are members AB, AC, AD etc. then the equilibrium conditions for directions X and Y are:

$$\left. \begin{aligned} t_{AB}(x_B - x_A) + t_{AC}(x_C - x_A) + t_{AD}(x_D - x_A) + \dots + X_A &= 0 \\ t_{AB}(y_B - y_A) + t_{AC}(y_C - y_A) + t_{AD}(y_D - y_A) + \dots + Y_A &= 0 \end{aligned} \right\} (3.10)$$

3/6 Theory of structures

Similar equations can be formed at each joint in the truss. Having solved the equations, for the tension coefficients, usually a very simple process, the forces in the members are determined from Equation (3.9).

The extension of the theory to space trusses is straightforward. At each joint we now have three equations of equilibrium, similar to Equation (3.10) with the addition of an equation representing equilibrium in the Z direction:

$$t_{AB}(z_B - z_A) + t_{AC}(z_C - z_A) + \dots + Z_A = 0 \tag{3.11}$$

The method will now be illustrated with an example. The notation is simplified by writing AB in place of  $t_{AB}$  etc. A fabular presentation of the work is recommended.

**Example 3.1.** A pin-jointed space truss is shown in Figure 3.5. It is required to determine the forces in the members using the method of tension coefficients. We first check that the frame is statically determinate as follows:

- Number of members = 6
- Number of reactions = 9
- Total number of unknowns = 15

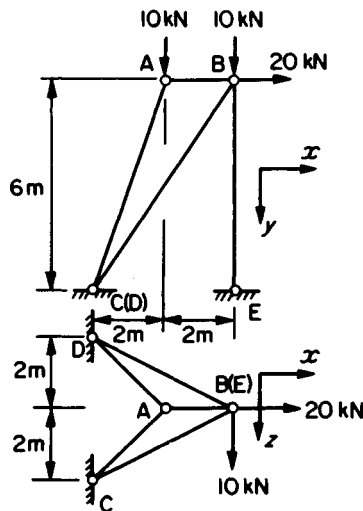

Figure 3.5

The number of equations available is 3 times the number of joints, i.e.  $3 \times 5 = 15$ . Hence, the truss is statically determinate. In counting the number of reactive components, it should be observed that all components should be included even if the particular geometry of the truss dictates (as in this case at E) that one or more components should be zero.

The solution is set out in Tables 3.1 and 3.2 where it should be noted that, in deriving the equations, the origin of coordinates is taken at the joint being considered. Thus, each tension coefficient is multiplied by the projection of the member on the particular axis.

The methods of truss analysis just outlined are suitable for 'hand' analysis, as distinct from computer analysis, and are useful in acquiring familiarity and understanding of structural behaviour. Much analysis of this kind is now carried out on computers (mainframe, mini- and microcomputers) where the stiffness method provides a highly organized and suitable basis. This topic will be further considered under the heading of the stiffness method.

Table 3.1

Joint	Direction	Equations	Solutions
A	x	$-2AC - 2AD + 2AB = 0$	$AC = AD = -\frac{10}{12}$
	y	$6AC + 6AD + 10 = 0$	$AB = -\frac{10}{6}$
	z	$2AC - 2AD = 0$	$-4BC - 4BD + \frac{10}{3} + 20 = 0$ $2BC - 2BD + 10 = 0$
C	x	$-4BC - 4BD - 2AB + 20 = 0$	$BC = \frac{10}{24}$
	y	$6BC + 6BD + 6BE + 10 = 0$	$BD = \frac{130}{24}$
	z	$-2BD + 2BC + 10 = 0$	Hence $BE = -\frac{15}{2}$

Table 3.2

Member	Length (m)	Tension coefficient	Force (kN) (tension +)
AB	2	$-\frac{10}{6}$	-3.33
AC	6.62	$-\frac{10}{12}$	-5.52
AD	6.62	$-\frac{10}{12}$	-5.52
BC	7.48	$\frac{10}{24}$	+3.12
BD	7.48	$\frac{130}{24}$	+40.5
BE	6	$-\frac{15}{2}$	-45.0

### 3.3 The flexibility method

#### 3.3.1 Introduction

The idea of statical determinacy was introduced previously (see page 3/4) and a relationship between the degree of statical indeterminacy and the numbers of members, nodes and releases was stated in Equation (3.5). A statically determinate structure is one for which it is possible to determine the values of forces at all points by the use of equilibrium conditions alone. A statically indeterminate structure, by virtue of the number of members or method of connecting the members together, or the method of support of the structure, has a larger number of forces than can be determined by the application of equilibrium principles alone. In such structures the force analysis requires the use of compatibility conditions. The flexibility method provides a means of analysing statically indeterminate structures.

Consider the propped cantilever shown in Figure 3.6(a). Applying Equation (3.5) the degree of statical indeterminacy is seen to be:

$$n_s = 3(2 - 2 + 1) - 2 = 1$$

(Note that two releases are required at B, one to permit angular rotation and one to permit horizontal sliding, and also that an additional foundation member is inserted connecting A and B.) The structure can be made statically determinate by removing the propping force  $R_b$  or alternatively by removing the fixing moment at A. We shall proceed by removing the reaction  $R_b$ . The structure thus becomes the simple cantilever shown in Figure 3.6(b). The application of the load  $w$  produces the deflected shape, shown dotted, and in particular a deflection  $u$  at the free end B. Note also that it is now possible to determine the bending moment at  $A = wl^2/2$ , by simple statical principles. The

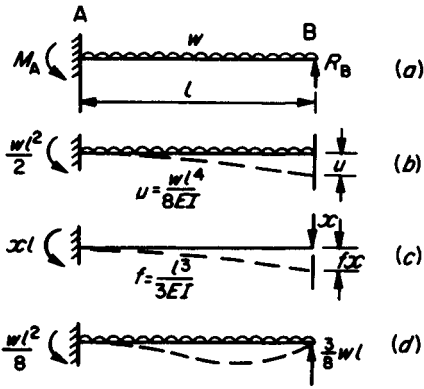

Figure 3.6 Basis of the flexibility method

deflection  $u$  may be obtained from elementary beam theory as  $wl^4/8EI$ . We now remove the applied load  $w$  and apply the, unknown, redundant force  $x$  at B. It is unnecessary to know the sense of the force  $x$ ; in this case we have assumed a downwards direction for positive  $x$ . The application of the force  $x$  produces a displacement at B which we shall call  $fx$ ; i.e. a unit value of  $x$  would produce a displacement  $f$ . The compatibility condition associated with the redundant force  $x$  is that the final displacement at B should be zero, i.e.:

$$u + fx = 0 \tag{3.12}$$

and substituting values of  $u$  and  $f$

$$x = -\frac{3}{8}wl$$

The process may be regarded as the superposition of the diagrams Figures 3.6(b) and (c) such that the final displacement at B is zero. The addition of the two systems of forces will also give values of bending moment throughout the beam, e.g. at A:

$$\begin{aligned} M_A &= \frac{wl^2}{2} + xl \\ &= \frac{wl^2}{2} - \frac{3}{8}wl^2 = \frac{wl^2}{8} \end{aligned}$$

The actual values of reactions are as shown in Figure 3.6(d). The displacement  $f$  is called a 'flexibility influence coefficient'. In general  $f_{rs}$  is the displacement in direction  $r$  in a structure due to unit force in direction  $s$ . The subscripts were omitted in the above analysis since the force and displacement considered were at the same position and in the same direction.

### 3.3.2 Evaluation of flexibility influence coefficients

As seen in the above example, flexibility coefficients are displacements calculated at specified positions, and directions, in a structure due to a prescribed loading condition. The loading condition is that of a single unit load replacing a redundant force in the structure. It should be remembered that at this stage the structure is, or has been made, statically determinate.

For simplicity we restrict our attention to structures in which flexural deformations predominate. The extension to other types of deformation is straightforward.<sup>3</sup> In the case of pure flexural deformation we may evaluate displacements by an application of Castiglano's theorem or use the principle of virtual work.<sup>3</sup> In either case a convenient form is:

$$\Delta_i = \int M \frac{\partial M}{\partial F_i} \frac{ds}{EI} \tag{3.13}$$

in which  $\Delta_i$  is the displacement required,  $M$  is a function representing the bending moment distribution and  $F_i$  is a force, real or virtual, applied at the position and in the direction designated by  $i$ . It follows that  $\partial M/\partial F_i$  can be regarded as the bending moment distribution due to unit value of  $F_i$ .

Consider the cantilever beam shown in Figure 3.7(a). Forces  $x_1$  and  $x_2$  act on the beam and it is required to determine influence coefficients corresponding to the positions and directions defined by  $x_1$  and  $x_2$ . From now on we work with unit values of  $x_1$  and  $x_2$  and draw bending moment diagrams, as in Figure 3.7(b) and (c), due to unit values of  $x_1$  and  $x_2$  separately.

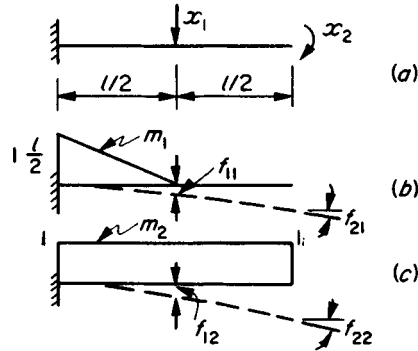

Figure 3.7 Evaluation of flexibility coefficients

These are labelled  $m_1$  and  $m_2$ . Consider the application of unit force at  $x_1$  ( $x_2 = 0$ ). Displacements will occur in the directions of  $x_1$  and  $x_2$ . Applying Equation (3.13) the displacement in the direction of  $x_1$  will be:

$$\left. \begin{aligned} f_{11} &= \int m_1 m_1 \frac{ds}{EI} \\ \text{and in the direction of } x_2: \\ f_{21} &= \int m_2 m_1 \frac{ds}{EI} \end{aligned} \right\} \tag{3.14}$$

Similarly, when we apply  $x_2 = 1$ ,  $x_1 = 0$ , we obtain:

$$\left. \begin{aligned} f_{22} &= \int m_2 m_2 \frac{ds}{EI} \\ \text{and:} \\ f_{12} &= \int m_1 m_2 \frac{ds}{EI} \end{aligned} \right\} \tag{3.15}$$

The general form is:

$$f_{rs} = \int m_r m_s \frac{ds}{EI} \tag{3.16}$$

The evaluation of Equation (3.16) requires the integration of the product of two bending moment distributions over the complete structure. Such distributions can generally be represented by simple geometrical figures such as rectangles, triangles and

### 3/8 Theory of structures

parabolas and standard results can be established in advance. Table 3.3 gives values of product integrals for a range of combinations of diagrams. It should be noted that in applying Equation (3.16) in this way, the flexural rigidity  $EI$  is assumed constant over the length of the diagram.

We may now use Table 3.3 to obtain values of the flexibility coefficients for the cantilever beam under consideration. Using Equations (3.14) and (3.15) with Figures 3.7(b) and (c) we obtain:

$$f_{11} = \frac{1}{3} \cdot \frac{l}{2} \cdot \frac{l}{2} \cdot \frac{1}{EI} = \frac{l^3}{24EI}$$

$$f_{21} = \frac{1}{2} \cdot \frac{l}{2} \cdot 1 \cdot \frac{1}{EI} = \frac{l^2}{8EI}$$

$$f_{22} = l \cdot 1 \cdot 1 \cdot \frac{1}{EI} = \frac{l}{EI}$$

$$f_{12} = \frac{1}{2} \cdot \frac{l}{2} \cdot \frac{l}{2} \cdot 1 \cdot \frac{1}{EI} = \frac{l^3}{8EI}$$

It is seen that  $f_{21}$  and  $f_{12}$  are numerically equal, a result which could be established using the Reciprocal Theorem. This is a useful property since in general  $f_{rs} = f_{sr}$  and the effect is to reduce the number of separate calculations required. It should be further noted that whilst  $f_{21} = f_{12}$ ,  $f_{21}$  is an angular displacement and  $f_{12}$  a linear displacement.

The evaluation of the flexibility coefficients  $f_{rs}$  provides the displacements at selected points in the structure due to unit values of the associated, redundant, forces. Before the compatibility conditions can be written down, it remains to calculate displacements ( $u$ ) at corresponding positions due to the actual applied load. The basic equation (Equation 3.13) is applied once more. Now the bending moment distribution  $M$  is that due to the applied loads and we will re-designate this  $m_0$ . As before,  $\partial M / \partial F_i = m_i$ , and thus:

$$u_i = \int m_0 m_i \frac{ds}{EI} \quad (3.17)$$

The table of product integrals, Table 3.3, can be used for evaluating the  $u_i$  in the same way as the  $f_{rs}$ .

Table 3.3

	Product integrals (EI uniform)	$\int_0^l m_r m_s ds$		
$m_s \backslash m_r$				
	$l a c$	$\frac{1}{2} a c$	$\frac{1}{2} (a+b) c$	
	$\frac{1}{2} a c$	$\frac{1}{3} a c$	$\frac{1}{6} (2a+b) c$	
	$\frac{1}{2} a c$	$\frac{1}{6} a c$	$\frac{1}{6} (a+2b) c$	
	$\frac{1}{2} a (c+d)$	$\frac{1}{6} a (2c+d)$	$\frac{1}{6} \{ a(2c+d) + b(2d+c) \}$	
	$\frac{2}{3} l a c$	$\frac{1}{3} a c$	$\frac{1}{3} (a+b) c$	

In cases where the bending moment diagrams do not fit the standard values given in Table 3.3 or where a member has a stepped variation in  $EI$ , the member may be divided into segments such that the standard results can be applied and the total displacement obtained by addition. In cases where the standard results cannot be applied, e.g. a continuous variation in  $EI$ , the integration can be carried out conveniently by the use of Simpson's rule:

$$\int m_i m_s \frac{ds}{EI} \approx \frac{a}{3} (h_1 + 4h_2 + 2h_3 + 4h_4 + \dots + h_n)$$

where  $a$  = width of strip

$$h_i = \frac{m_i m_s}{EI} \text{ at section } i.$$

In using Simpson's rule it should be remembered that the number of strips must be even, i.e.  $n$  must be odd.

#### 3.3.2.1 Sign convention

A flexibility coefficient will be positive if the displacement it represents is in the same sense as the applied, unit, force. The bending moment expressions must carry signs based on the type of curvature developing in the structure. Since the integrand in Equation (3.16) is always the product of two bending moment expressions, it is only the relative sign which is of importance. A useful convention is to draw the diagrams on the tension (convex) sides of the members and then the relative signs of  $m_i$  and  $m_s$  can readily be seen. In Figure 3.7(b) and (c), both the  $m_1$  and  $m_2$  diagrams are drawn on the top side of the member. Their product is therefore positive. Naturally, the product of one diagram and itself will always be positive. This follows from simple physical reasoning since the displacement at a point due to an applied force at the same point will always be in the same sense as the applied force.

#### 3.3.3 Application to beam and rigid frame analysis

The application of the theory will now be illustrated with two examples.

*Example 3.2.* Consider the three-span continuous beam shown in Figure 3.8(a). The beam is statically indeterminate to the second degree and we shall choose as redundants the internal bending moments at the interior supports B and C. The beam is made statically determinate by the introduction of moment releases at B and C as in Figure 3.8(b). We note that the application of the load  $W$  now produces displacements in span BC only, and in particular rotations  $u_1$  and  $u_2$  at B and C. The bending moment diagram ( $m_0$ ) is shown in Figure 3.8(c).

We now apply unit value of  $x_1$  and  $x_2$  in turn. The deflected shapes and the flexibility coefficients, in the form of angular rotations, are shown at (d) and (e). The bending moment diagrams  $m_1$  and  $m_2$  are shown at (f) and (g).

Using the table of product integrals (Table 3.3), we find:

$$EI f_{11} = \frac{2}{3} l$$

$$EI f_{22} = \frac{2}{3} l$$

$$EI f_{12} = EI f_{21} = \frac{1}{6} l$$

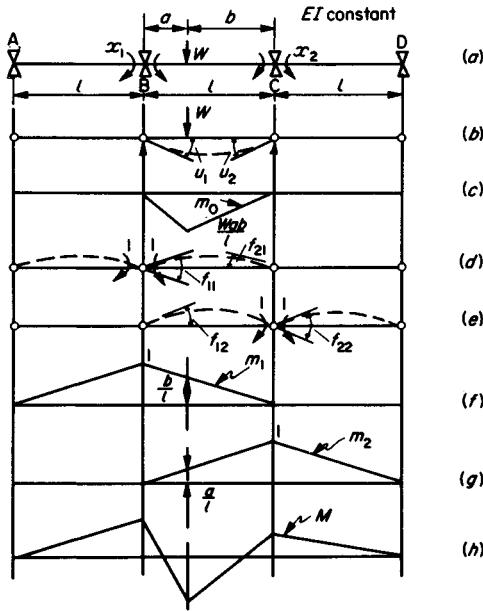

Figure 3.8 Flexibility analysis of continuous beam

$$EI u_1 = -\frac{a}{6} \left(1 + \frac{2b}{l}\right) \frac{Wab}{l} - \frac{b}{3} \frac{b}{l} \cdot \frac{Wab}{l}$$

$$= -\frac{Wab}{6l} (a + 2b)$$

and

$$EI u_2 = -\frac{Wab}{6l} (b + 2a)$$

The required compatibility conditions are, for continuity of the beam:

$$\text{at B, } f_{11}x_1 + f_{12}x_2 + u_1 = 0$$

$$\text{at C, } f_{21}x_1 + f_{22}x_2 + u_2 = 0$$

or, in matrix form:

$$FX + U = 0 \tag{3.18}$$

i.e.:

$$\frac{l}{6EI} \begin{bmatrix} 4 & 1 \\ 1 & 4 \end{bmatrix} \begin{bmatrix} x_1 \\ x_2 \end{bmatrix} = \frac{Wab}{16EI} \begin{bmatrix} (a+2b) \\ (b+2a) \end{bmatrix}$$

and the solutions are:

$$\begin{bmatrix} x_1 \\ x_2 \end{bmatrix} = \frac{Wab}{15l^2} \begin{bmatrix} (2a+7b) \\ (2b+7a) \end{bmatrix}$$

The actual bending moment distribution may now be determined by the addition of the three systems, i.e. the applied load and the two redundants. The general expression is:

$$M = m_0 + m_1x_1 + m_2x_2 \tag{3.19}$$

In particular:

$$M_B = x_1 = \frac{Wab}{15l^2}(2a + 7b)$$

$$M_C = x_2 = \frac{Wab}{15l^2}(2b + 7a)$$

and the bending moment under the load  $W$  is:

$$M_w = -\frac{Wab}{l} + \frac{b}{l}x_1 + \frac{a}{l}x_2$$

$$= -\frac{2Wab}{15l^3}(4l^2 + 5ab)$$

The final bending moment diagram is shown in Figure 3.8(h).

**Example 3.3.** A portal frame ABCD is shown in Figure 3.9(a). The frame has rigid joints at B and C, a fixed support at A and a hinged support at D. The flexural rigidity of the beam is twice that of the columns.

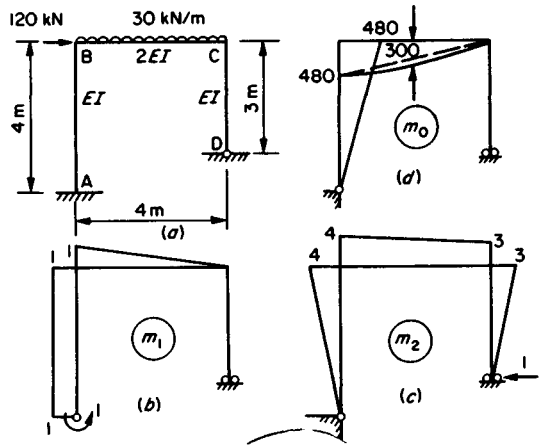

Figure 3.9

The frame has two redundancies and these are taken to be the fixing moment at A and the horizontal reaction at D. The bending moment diagrams corresponding to the unit redundancies,  $m_1$  and  $m_2$  and the applied load,  $m_0$ , are shown at (b), (c) and (d) in Figure 3.9.

Using the table of product integrals, Table 3.3, we obtain:

$$f_{11} = \int m_1^2 \frac{ds}{EI} = \frac{14}{3EI}$$

$$f_{22} = \int m_2^2 \frac{ds}{EI} = \frac{55}{EI}$$

$$f_{12} = f_{21} = \int m_1 m_2 \frac{ds}{EI} = \frac{35}{3EI}$$

$$u_1 = \int m_0 m_1 \frac{ds}{EI} = -\frac{1320}{EI}$$

$$u_2 = \int m_0 m_2 \frac{ds}{EI} = -\frac{4600}{EI}$$

Thus the compatibility equations are:

$$\frac{1}{3} \begin{bmatrix} 14 & 35 \\ 35 & 165 \end{bmatrix} \begin{bmatrix} x_1 \\ x_2 \end{bmatrix} = + \begin{bmatrix} 1320 \\ 4600 \end{bmatrix}$$

3/10 Theory of structures

from which

$$x_1 = + 157 \text{ kNm}$$

and

$$x_2 = + 50 \text{ kN}$$

The bending moment at any point in the frame may now be determined from the expression:

$$M = m_0 + m_1 x_1 + m_2 x_2$$

e.g.:

$$M_{BA} = 480 - 1(157) - 4(50) = 123 \text{ kNm}$$

and

$$M_{CD} = 3x_2 = 150 \text{ kNm}$$

3.3.4 Application to truss analysis

The analysis of statically indeterminate trusses follows closely on that established for rigid frames; however, the problem is simplified due to the fact that for each system of loading investigated, the axial forces are constant within the lengths of the members and thus the integration is considerably simplified. We are now concerned with deformations in the members due to axial forces only and the flexibility coefficients are:

$$f_{rs} = \sum p_r p_s \frac{l}{AE} \tag{3.20}$$

and

$$u_i = \sum p_0 p_i \frac{l}{AE} \tag{3.21}$$

in which the  $p_r$  system of forces is due to unit tension in the  $r$ th redundant member and similarly for  $p_s$  and  $p_i$ . The  $p_0$  system of forces is that due to the applied load system acting on the statically determinate structure (i.e. with the redundant members omitted). Equations (3.20) and (3.21) should be compared with Equations (3.16) and (3.17) in the flexural case.

**Example 3.4.** The plane truss shown in Figure 3.10 has two redundancies which we will choose as the forces in members AE and EC. AE is constant for all the members and equal to  $1 \times 10^6$  kN. The member EC is  $l/10\,000$  short in manufacture and has to be forced into position. The member force systems  $p_0$ ,  $p_1$  and  $p_2$  are found from a simple statical analysis and are listed in Table 3.4.

The flexibility coefficients may now be obtained as follows:

$$f_{11} = \sum p_1 p_1 \frac{l}{AE} = \frac{2l}{AE}(1 + \sqrt{2})$$

$$f_{22} = f_{11}$$

$$f_{12} = f_{21} = \sum p_1 p_2 \frac{l}{AE} = \frac{l}{2AE}$$

$$u_1 = \sum p_1 p_0 \frac{l}{AE} = \frac{Wl}{AE}(1 + 1/\sqrt{2})$$

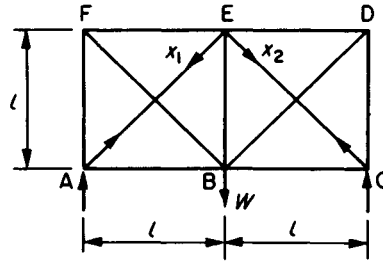

Figure 3.10

Table 3.4

Member	Length	$p_0/w$	$p_1$	$p_2$
AB	$l$	0	$-1/\sqrt{2}$	0
BC	$l$	0	0	$-1/\sqrt{2}$
CD	$l$	$-1/2$	0	$-1/\sqrt{2}$
DE	$l$	$-1/2$	0	$-1/\sqrt{2}$
EF	$l$	$-1/2$	$-1/\sqrt{2}$	0
AF	$l$	$-1/2$	$-1/\sqrt{2}$	0
FB	$\sqrt{2}l$	$1/\sqrt{2}$	1	0
BE	$l$	0	$-1/\sqrt{2}$	$-1/\sqrt{2}$
BD	$\sqrt{2}l$	$1/\sqrt{2}$	0	1
AE	$\sqrt{2}l$	0	1	0
EC	$\sqrt{2}l$	0	0	1

Ignoring, for the moment, the effect of the shortness in length of member EC, the compatibility equations are:

$$f_{11}x_1 + f_{12}x_2 + u_1 = 0$$

$$f_{21}x_1 + f_{22}x_2 + u_2 = 0$$

Clearly the symmetry will produce  $x_1 = x_2$  and thus:

$$x_1 = x_2 = -W \frac{(2 + \sqrt{2})}{(5 + 4\sqrt{2})}$$

The effect of the prestrain caused by the forced fit of member EC may be obtained by putting:

$$U = - \begin{bmatrix} 0 \\ 10^{-4}l \end{bmatrix} \tag{3.22}$$

and then solving  $FX + U = 0$  obtaining:

$$x_1 = \frac{-200}{(47 + 32\sqrt{2})} \text{ kN}$$

$$x_2 = \frac{800(1 + \sqrt{2})}{(47 + 32\sqrt{2})} \text{ kN}$$

The forces in the other members may now be obtained from  $p = p_0 + p_1 x_1 + p_2 x_2$ .

The sign of the lack of fit in Equation (3.22) should be studied carefully and it should be noted that the convention for the signs of forces is tension-positive throughout.

3.3.5 Comments on the flexibility method

For a more detailed treatment of the flexibility method the reader may consult any of the standard texts, e.g. Jenkins' and

Coates, Coutie and Kong.<sup>2</sup> The method has declined in popularity in recent years due to the widespread adoption of computerized methods based on *stiffness* concepts. In the context of automatic computation, the stiffness method, which will be considered in the next section, offers considerable advantages over the flexibility method. Methods based on flexibility offer some advantage for hand computation in structures with low (1 or 2) degrees of statical indeterminacy or with lack of fit, temperature change or flexible supports. The concept of flexibility influence coefficients is also useful in determining stiffness coefficients, e.g. in nonprismatic members.

### 3.4 The stiffness method

#### 3.4.1 Introduction

This method has been very extensively developed in recent years and now forms the basis of most structural analysis carried out on digital computers. The method of 'slope-deflection' is an example of the application of the general stiffness method.

Consider the structure shown in Figure 3.11(a) which is fixed at A and C and has a rigid joint at B. The degree of kinematical indeterminacy, from Equation (3.6), is:

$$\begin{aligned} n_k &= 3(n-1) - c + r \\ &= 3(3-1) - 5 + 0 \\ &= 1 \end{aligned}$$

The five constraints are the zero displacements, three at C and two at B, related to the fixed point A. The single unknown

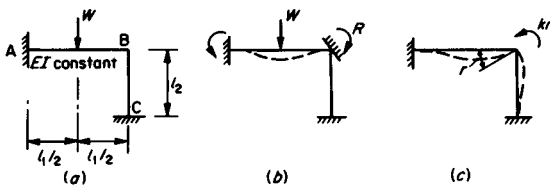

Figure 3.11 Basis of the stiffness method

displacement, nodal degree of freedom is, of course, the rotation of the joint B.

The procedure is to clamp the joint B so constraining the nodal degree of freedom *r*. On applying the load *W*, a constraining force, *R*, will be required at B to prevent the rotation of the joint. The constraining force *R* is now applied to the, otherwise unloaded, structure with its sign reversed and the nodal degree of freedom released. The result is a rotation of joint B through angle *r*. The external moment required to effect this rotation is *kr* where *k* is the stiffness of the structure for this particular displacement. Thus, for equilibrium:

$$kr = R \tag{3.23}$$

From the table of fixed-end moments, Table 3.5:

$$R = \frac{Wl_1}{8}$$

and from the force-displacement relationships of Equation (3.1)

$$k = \frac{4EI}{l_1} + \frac{4EI}{l_2}$$

Thus:

$$4EI \left( \frac{1}{l_1} + \frac{1}{l_2} \right) r = \frac{Wl_1}{8}$$

Hence:

$$r = \frac{Wl_1 l_2}{32EI(l_1 + l_2)}$$

The member forces are now obtained by adding the two systems (b) and (c) in Figure 3.11, e.g.:

$$\begin{aligned} M_{BA} &= \frac{Wl_1}{8} - \frac{4EI(r)}{l_1} = \frac{Wl_1}{8} \left( 1 - \frac{l_2}{l_1 + l_2} \right) \\ &= \frac{Wl_1^2}{8(l_1 + l_2)} \end{aligned}$$

and

$$M_{BC} = -\frac{4EI(r)}{l_2} = -\frac{Wl_1^2}{8(l_1 + l_2)}$$

Note that in the above, clockwise moments are considered positive.

Table 3.5 Fix-end moments for uniform beams (clockwise moments positive)

$M_{FL}$	Loading	$M_{FR}$
$-\frac{Wab}{l} \left( \frac{b}{l} \right)$		$\frac{Wab}{l} \left( \frac{a}{l} \right)$
$-\frac{Wab}{2l^2} (a+2b)$		0
$-\frac{Wc}{12l^2} [12ab^2 + c^2 (a-2b)]$		$\frac{Wc}{12l^2} [12a^2b + c^2 (b-2a)]$
$-\frac{wl^2}{12}$		$\frac{wl^2}{12}$
$-\frac{wl^2}{30}$		$\frac{wl^2}{20}$
$-\frac{5}{96} wl^2$		$\frac{5}{96} wl^2$
$\frac{Mb}{l^2} (2a-b)$		$\frac{Ma}{l^2} (2b-a)$
$\frac{M}{2l^2} (l^2 - 3b^2)$		0

#### 3.4.2 Member stiffness matrix

In the stiffness method, a structure is considered to be an assemblage of discrete elements, beams, columns, plates, etc. and the method requires a knowledge of the stiffness characteristics of the elements. In the 'finite element' method (see page 3/14) an artificial discretization of the structure is adopted. As an

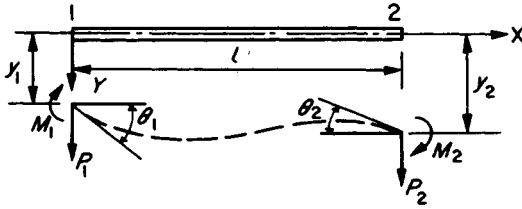

Figure 3.12 Structural beam element

example of the determination of stiffness influencing coefficients we shall consider the simple beam element shown in Figure 3.12. We neglect any axial deformation.

The expression for the bending moment in the beam with origin at end 1 and deflections  $y$  positive downwards is:

$$EI d^2y/dx^2 = P_1 x - M_1$$

Integrating

$$EI dy/dx = \frac{P_1 x^2}{2} - M_1 x + C_1$$

$$= EI \theta_1 \text{ for } x=0$$

Hence:

$$C_1 = EI \theta_1$$

$$= EI \theta_2 \text{ for } x=l$$

Hence:

$$EI(\theta_2 - \theta_1) = \frac{P_1 l^2}{2} - M_1 l \tag{3.24}$$

Integrating again:

$$EI y = \frac{P_1 x^3}{6} - M_1 \frac{x^2}{2} + EI \theta_1 x + C_2$$

$$= EI y_1 \text{ for } x=0$$

Therefore:

$$C_2 = EI y_1$$

$$= EI y_2 \text{ for } x=l$$

Hence:

$$EI(y_2 - y_1) - EI \theta_1 l = P_1 \frac{l^3}{6} - M_1 \frac{l^2}{2} \tag{3.25}$$

Solving equations (3.24) and (3.25) for  $M_1$  and  $P_1$ :

$$M_1 = \frac{4EI \theta_1}{l} + \frac{6EI y_1}{l^2} + \frac{2EI \theta_2}{l} - \frac{6EI y_2}{l^2} \tag{3.26}$$

and

$$P_1 = \frac{6EI \theta_1}{l^2} + \frac{12EI y_1}{l^3} + \frac{6EI \theta_2}{l^2} - \frac{12EI y_2}{l^3} \tag{3.27}$$

Two further relationships between the forces and displacements are obtained from static equilibrium as follows:

For vertical equilibrium,  $P_1 + P_2 = 0$

Hence:

$$P_2 = -P_1 \tag{3.28}$$

Taking moments about end 1:

$$\begin{aligned} M_2 &= -M_1 - P_2 l \\ &= \frac{2EI \theta_1}{l} + \frac{6EI y_1}{l^2} + \frac{4EI \theta_2}{l} - \frac{6EI y_2}{l^2} \end{aligned} \tag{3.29}$$

Equations (3.26)–(3.29) may be combined in the matrix form:

$$\begin{bmatrix} M_1 \\ P_1 \\ M_2 \\ P_2 \end{bmatrix} = \frac{EI}{l^3} \begin{bmatrix} 4l^2 & 6l & 2l^2 & -6l \\ 6l & 12 & 6l & -12 \\ -6l & -12 & -6l & 12 \end{bmatrix} \begin{bmatrix} \theta_1 \\ y_1 \\ \theta_2 \\ y_2 \end{bmatrix}$$

$$\text{or } \mathbf{S} = \mathbf{k} \Delta \tag{3.30}$$

The matrix  $\mathbf{k}$  is the stiffness matrix of the beam, and  $\mathbf{S}$  and  $\Delta$  are the matrices of member forces and nodal displacements respectively. Equation (3.30) expresses the force–displacement relationships for the beam in the *stiffness* form as distinct from the *flexibility* form. The symmetry of the matrix should be noted as consistent with the symmetry exhibited by flexibility coefficients (see page 3/9).

### 3.4.3 Assembly of structure stiffness matrix

The stiffness method involves the solution of a set of linear simultaneous equations, representing equilibrium conditions, which may be expressed in the form:

$$\mathbf{K} \mathbf{r} = \mathbf{R} \tag{3.31}$$

Equation (3.31) is similar in form to Equation (3.23) with the important difference that now we are concerned with a multiple degree of freedom system as distinct from a single unknown displacement.  $\mathbf{K}$  is the structure stiffness matrix,  $\mathbf{r}$  is a matrix of nodal displacements and  $\mathbf{R}$  a matrix of applied nodal forces.

The process of assembling the matrix  $\mathbf{K}$  is one of transferring individual element stiffnesses into appropriate positions in the matrix  $\mathbf{K}$ . Naturally, this has been the subject of considerable organization for digital computer analysis and the subject is well documented.<sup>3</sup> Some aspects of a computerized approach will be considered later but the basic process will be illustrated here using a simple example. Consider the structure shown in Figure 3.13(a). The two beams are rigidly connected together at B where there is a spring support with stiffness  $k_s$ . End A is hinged and end C fixed. The structure has three degrees of freedom, rotations  $r_1$  and  $r_3$  at A and B and a vertical displacement  $r_2$  at B. The stiffness matrix for each beam has the form of Equation (3.30) from which  $\mathbf{k}$  may be written in the general form:

$$\mathbf{k} = \begin{bmatrix} k_{11} & k_{12} & k_{13} & k_{14} \\ k_{21} & k_{22} & k_{23} & k_{24} \\ k_{31} & k_{32} & k_{33} & k_{34} \\ k_{41} & k_{42} & k_{43} & k_{44} \end{bmatrix} \tag{3.32}$$

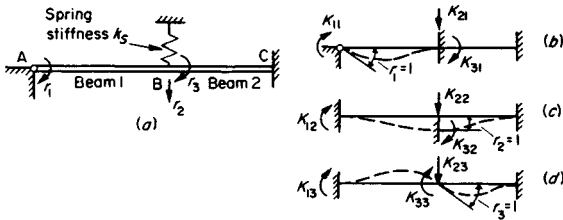

Figure 3.13

where  $k_{11} = 4EI/l$ ;  $k_{12} = 6EI/l^2$ , etc.

We apply unit value of each degree of freedom in turn as shown in Figure 3.13(b), (c) and (d). It should be noted that when  $r_1 = 1$  is applied,  $r_2$  and  $r_3$  are constrained at zero value and similarly with  $r_2 = 1$  and  $r_3 = 1$ . The force systems necessary to achieve the unit values of the degrees of freedom are also shown at (b), (c) and (d). The equilibrium conditions are clearly:

$$K_{11}r_1 + K_{12}r_2 + K_{13}r_3 = R_1$$

$$K_{21}r_1 + K_{22}r_2 + K_{23}r_3 = R_2$$

$$K_{31}r_1 + K_{32}r_2 + K_{33}r_3 = R_3$$

i.e.  $\mathbf{K}\mathbf{r} = \mathbf{R}$

where  $\mathbf{R}$  is the matrix of applied loads. Clearly, the forces shown in Figure 3.13(b), (c) and (d) constitute the elements of the stiffness matrix  $\mathbf{K}$  and this may now be assembled by inspection. Using the individual beam elements from Equation (3.30) with the notation of Equation (3.32):

$$\mathbf{K} = \begin{bmatrix} (k_{11})_1 & -(k_{12})_1 & (k_{13})_1 \\ -(k_{12})_1 & (k_{44})_1 + (k_{22})_2 + k_s & (k_{23})_2 - (k_{14})_1 \\ (k_{13})_1 & (k_{23})_2 - (k_{14})_1 & (k_{33})_1 + (k_{11})_2 \end{bmatrix} \quad (3.33)$$

and more specifically:

$$\mathbf{K} = \begin{bmatrix} 4\left(\frac{EI}{l}\right)_1 & -6\left(\frac{EI}{l^2}\right)_1 & 2\left(\frac{EI}{l}\right)_1 \\ -6\left(\frac{EI}{l^2}\right)_1 & 12\left(\frac{EI}{l^3}\right)_1 + 12\left(\frac{EI}{l^3}\right)_2 + k_s & 6\left(\frac{EI}{l^2}\right)_2 - 6\left(\frac{EI}{l^2}\right)_1 \\ 2\left(\frac{EI}{l}\right)_1 & 6\left(\frac{EI}{l^2}\right)_2 - 6\left(\frac{EI}{l^2}\right)_1 & 4\left(\frac{EI}{l}\right)_1 + 4\left(\frac{EI}{l}\right)_2 \end{bmatrix} \quad (3.34)$$

### 3.4.4 Stiffness transformations

The member stiffness matrix  $\mathbf{k}$  in Equation (3.30) is based on a coordinate system which is convenient for the member, i.e. origin at one end and X-axis directed along the axis of the beam. Such a coordinate system is termed 'local' as distinct from the 'global' coordinate system which is used for the complete structure. This subject is considered in detail in a number of

texts<sup>2,3</sup> and we shall give only a brief indication of the type of computation required.

Consider a three-dimensional coordinate system  $\bar{XYZ}$  (global) which is obtained by rotation of the (local) coordinate system  $XYZ$ . In the local system the force-displacement relationships for a beam element may be expressed in the partitioned matrix form:

$$\begin{bmatrix} \bar{\mathbf{S}}_1 \\ \bar{\mathbf{S}}_2 \end{bmatrix} = \begin{bmatrix} \mathbf{k}_{11} & \mathbf{k}_{12} \\ \mathbf{k}_{21} & \mathbf{k}_{22} \end{bmatrix} \begin{bmatrix} \mathbf{r}_1 \\ \mathbf{r}_2 \end{bmatrix} \quad (3.35)$$

in which the subscripts refer to ends 1 and 2.

The stiffness expressed in the coordinate system  $\bar{XYZ}$  may be obtained as follows:

$$\begin{bmatrix} \bar{\mathbf{S}}_1 \\ \bar{\mathbf{S}}_2 \end{bmatrix} = \begin{bmatrix} \lambda \mathbf{k}_{11} \lambda^T & \lambda \mathbf{k}_{12} \lambda^T \\ \lambda \mathbf{k}_{21} \lambda^T & \lambda \mathbf{k}_{22} \lambda^T \end{bmatrix} \begin{bmatrix} \mathbf{r}_1 \\ \mathbf{r}_2 \end{bmatrix} \quad (3.36)$$

in which  $\lambda$  is a matrix of direction cosines as follows:

$$\lambda = \begin{bmatrix} \lambda_{xx} & \lambda_{xy} & \lambda_{xz} & 0 & 0 & 0 \\ \lambda_{yx} & \lambda_{yy} & \lambda_{yz} & 0 & 0 & 0 \\ \lambda_{zx} & \lambda_{zy} & \lambda_{zz} & 0 & 0 & 0 \\ 0 & 0 & 0 & \lambda_{xx} & \lambda_{xy} & \lambda_{xz} \\ 0 & 0 & 0 & \lambda_{yx} & \lambda_{yy} & \lambda_{yz} \\ 0 & 0 & 0 & \lambda_{zx} & \lambda_{zy} & \lambda_{zz} \end{bmatrix} \quad (3.37)$$

where  $\lambda_{xx} = \cos \bar{XOX}$ , etc.

### 3.4.5 Some aspects of computerization of the stiffness method

The remarkable increase in popularity of the stiffness method is due to the widespread availability of relatively cheap computing power. The method is of limited practical use *except* on computers. The stiffness method is eminently suitable for computers because the setting up of the data describing the structure and loading system to be analysed is a comparatively simple operation. Although there is then generally considerable numerical computation to do, this is done by the computer. Thus the human effort required is minimized and the likelihood of errors being made also reduced. With the phenomenal development of cheap and powerful microcomputers, which are quite suitable for analysing most 'run-of-the-mill' structures, it is quite likely that in the very near future almost all structural analysis will be carried out on computers.

It will be useful to look briefly at the more important aspects of adapting the stiffness method for use on computers. The method may be viewed as a succession of six stages:

- 1) Define the nodal degrees of freedom of the structure ( $n$ ) (Equation (3.6)), the nodal 'coordinates'. The total number determines the size of the structure stiffness matrix  $\mathbf{K}$ . The ordering is a matter of convenience but in some programs a judicious ordering of coordinates is necessary to reduce the 'band width' of  $\mathbf{K}$ . An array  $\mathbf{K} (n \times n)$  is now generated in the computer and all elements are zeroed. This is necessary since component stiffnesses are going to be added-in to this array thus 'accumulating' the stiffnesses element by element.
- 2) The individual structural elements are now defined and their force-displacement relationships expressed in stiffness matrices,  $\mathbf{k}$  (Equation (3.30));  $\mathbf{S} = \mathbf{k}\mathbf{d}$ . The dimensions of these matrices will depend on the type of element used but for most of the common elements (beam, column, pin-jointed truss member, etc.) the standard matrices are pub-

lished in the textbooks. The element stiffnesses are now transformed from local to global coordinates using matrix transformations as in Equation (3.36).

- (3) The transformed stiffnesses are now transferred into appropriate locations of the structure stiffness matrix  $\mathbf{K}$ . Suppose we are to transfer the stiffnesses of a particular element and suppose this element has two coordinates numbered 1 and 2. If the coordinates in the actual structure which correspond to 1 and 2 of the element are, say,  $i$  and  $j$  then the transfer of stiffnesses is carried out as follows:

$$\begin{aligned} k_{11} &\rightarrow k_{ii} \\ k_{12} &\rightarrow k_{ij} \\ k_{21} &\rightarrow k_{ji} \\ k_{22} &\rightarrow k_{jj} \end{aligned}$$

There is considerable economy in organization and programming if the above procedure is applied to 'groups' of coordinates, e.g. all the displacements at one node. This can be achieved by *partitioning* the element stiffness matrices.

- (4) Once  $\mathbf{K}$  has been set up, the applied load matrix  $\mathbf{R}$  is generated. This is simply a column matrix containing the applied (nodal) loads arranged in the same order as the nodal coordinates. If the structure is carrying loads other than at the defined nodes, then such loads must be converted to statically equivalent nodal loads. In rigid frames, for example, this is easily done using the standard values of 'fixed-end' effects. If a concentrated load does not coincide with the defined nodal coordinates then it is a simple matter, as an alternative, to introduce a node at the load point. This procedure, although it increases the size of the system to be solved, does have the advantage of yielding the displacements developing at the load point.
- (5) The computer now solves the linear simultaneous equations (Equation (3.31))  $\mathbf{K}\mathbf{r}=\mathbf{R}$  to produce the nodal displacements  $\mathbf{r}$ .
- (6) Lastly, the element forces are obtained from Equation (3.30)  $\mathbf{S}=\mathbf{k}\Delta$ . In this last operation, some logical organization is clearly needed to extract the element nodal displacements  $\Delta$  from the structure displacement  $\mathbf{S}\mathbf{r}$ .

The foregoing is a description of the fundamental basis of the stiffness method applied on computers. Of course, it is possible to incorporate many refinements and devices to simplify the input and output, to check the results and to make changes in data without having to re-input all data.

In its most general form the stiffness method is used to analyse complex structures in which not only simple elements such as beams and columns are used but 'continua' such as plates and shells. This is the 'finite element' method which will now be examined briefly.

### 3.4.6 Finite element analysis

This extremely powerful method of analysis has been developed in recent years and is now an established method with wide applications in structural analysis and in other fields. Space permits only the most brief introduction here but the method is extensively documented elsewhere.<sup>4,6</sup> We have discussed the application of the stiffness method to framed structures in which the structural elements, beams and columns, have been connected at the nodes and the method observes the correct conditions of displacement compatibility and equilibrium at the nodes. The finite element method was developed, originally, in order to extend the stiffness method to the analysis of elastic continua such as plates and shells and indeed to three-dimensional continua. The first step in the process is to divide the structure into a finite number of discrete parts called 'elements'.

The elements may be of any convenient shape, e.g. a thin plate may be represented by triangular or rectangular elements, and the discretization may be *coarse*, with a small number of elements, or *fine*, with a large number of elements. The connection between elements now occurs not only at the nodal points but along boundary lines and over boundary faces.

The procedure ensures, as for framed structures, that equilibrium and compatibility conditions are satisfied at the nodes but the regions of connection between nodes are constrained to adopt a chosen form of displacement function. Thus, compatibility conditions along the interfaces between elements may not be completely satisfied and a degree of approximation is generally introduced. Once the geometry of the elements has been determined and the displacement function defined, the stiffness matrix of each element, relating nodal forces to nodal displacements, can be obtained. The remainder of the structural analysis follows the established procedures similar to those for framed structures. Naturally the best choice of element and discretization pattern, the precise conditions occurring at the interfaces and the accuracy of the solution, are matters which have received a great deal of attention in the literature.

A central stage in the process is the adoption of a suitable displacement function for the element chosen, and the subsequent evaluation of the element stiffnesses. This will be illustrated with one of the simplest possible elements, a triangular plate element for use in a plane stress situation.

#### 3.4.6.1 Triangular element for plane stress

A triangular element  $ijk$  is shown in Figure 3.14. Under load, the displacement of any point within the element is defined by the displacement components  $u, v$ . In particular the nodal displacements are:

$$\Delta = \{u_i u_k v_i v_j v_k\} \tag{3.38}$$

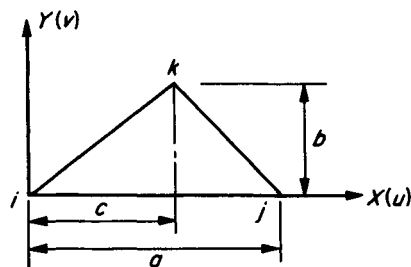

Figure 3.14

It is now assumed that the displacements  $u, v$  are linear functions of  $x, y$  as follows:

$$\begin{aligned} u &= \alpha_1 + \alpha_2 x + \alpha_3 y \\ v &= \alpha_4 + \alpha_5 x + \alpha_6 y \end{aligned} \tag{3.39}$$

The nodal displacements  $\Delta$  are now expressed in terms of the displacement parameters  $\alpha$ , from Equations (3.39) and Figure 3.14:

$$\begin{bmatrix} u_i \\ u_j \\ u_k \\ v_i \\ v_j \\ v_k \end{bmatrix} = \begin{bmatrix} 1 & 0 & 0 & 0 & 0 & 0 \\ 1 & a & 0 & 0 & 0 & 0 \\ 1 & c & b & 0 & 0 & 0 \\ 0 & 0 & 0 & 1 & 0 & 0 \\ 0 & 0 & 0 & 1 & a & 0 \\ 0 & 0 & 0 & 1 & c & b \end{bmatrix} \begin{bmatrix} \alpha_1 \\ \alpha_2 \\ \alpha_3 \\ \alpha_4 \\ \alpha_5 \\ \alpha_6 \end{bmatrix} \tag{3.40}$$

$$\text{or, } \Delta = \mathbf{A}\alpha$$

The strains in the element are functions of the derivatives of  $u$  and  $v$  as follows:

$$\epsilon = \begin{bmatrix} \epsilon_x \\ \epsilon_y \\ \gamma_{xy} \end{bmatrix} = \begin{bmatrix} \partial u / \partial x \\ \partial v / \partial y \\ \partial u / \partial y + \partial v / \partial x \end{bmatrix} \quad (3.41)$$

$$= \begin{bmatrix} 0 & 1 & 0 & 0 & 0 & 0 \\ 0 & 0 & 0 & 0 & 0 & 1 \\ 0 & 0 & 1 & 0 & 1 & 0 \end{bmatrix} \begin{bmatrix} \alpha_1 \\ \alpha_2 \\ \alpha_3 \\ \alpha_4 \\ \alpha_5 \\ \alpha_6 \end{bmatrix} \quad (3.42)$$

i.e.:

$$\epsilon = B\alpha = BA^{-1}\Delta \quad (3.43)$$

from Equation (3.40).

It should be noted that the matrix  $B$  in Equation (3.42) contains only constant terms and it follows that the strains are constant within the element.

The stress-strain relationships for plane stress in an isotropic material with Poisson's ratio  $\nu$  and Young's modulus  $E$  are:

$$\begin{bmatrix} \sigma_x \\ \sigma_y \\ \tau_{xy} \end{bmatrix} = \frac{E}{(1-\nu^2)} \begin{bmatrix} 1 & \nu & 0 \\ \nu & 1 & 0 \\ 0 & 0 & \frac{1}{2}(1-\nu) \end{bmatrix} \begin{bmatrix} \epsilon_x \\ \epsilon_y \\ \gamma_{xy} \end{bmatrix}$$

i.e.:

$$\sigma = D\epsilon = DBA^{-1}\Delta \quad (3.44)$$

Matrix  $D$  is the 'elasticity' matrix relating stress and strain. To obtain the element stiffness we employ the principle of virtual work and apply arbitrary nodal displacements  $\bar{\Delta}$  producing virtual strains in the element:

$$\bar{\epsilon} = BA^{-1}\bar{\Delta} \quad (3.45)$$

The virtual strain energy in the element, from Equation (2.78) of Chapter 2, is:

$$\int_{vol} \bar{\epsilon}^T \sigma dV$$

where  $V$  = volume of triangular element =  $tab/2$ ,  $t$  = thickness  
Substituting for  $\bar{\epsilon}^T$  and  $\sigma$  from Equations (3.45) and (3.44) respectively, the virtual strain energy is:

$$\int_{vol} [BA^{-1}\bar{\Delta}]^T DBA^{-1}\Delta dV$$

Now since all the matrices contain constant terms only and are thus independent of  $x$  and  $y$ , the expression for the virtual strain energy may be written:

$$\bar{\Delta}^T \{ [A^{-1}]^T B^T DBA^{-1} V \} \Delta$$

The external work is the product of the virtual displacements  $\bar{\Delta}$  and the nodal forces  $S$ , hence equating external virtual work and internal virtual strain energy:

$$\bar{\Delta}^T S = \bar{\Delta}^T \{ [A^{-1}]^T B^T DBA^{-1} V \} \Delta$$

The virtual displacements are quite arbitrary and in particular may be taken to be represented by a unit matrix, thus:

$$S = \{ [A^{-1}]^T B^T DBA^{-1} V \} \Delta \\ = k\Delta, \text{ from Equation (3.30)}$$

Thus:

$$k = [A^{-1}]^T B^T DBA^{-1} V \quad (3.46)$$

Before the matrix multiplications required in Equation (3.46) can be performed we need to find  $A^{-1}$ . This is easily determined as:

$$A^{-1} = \frac{1}{ab} \begin{bmatrix} ab & 0 & 0 & 0 & 0 & 0 \\ -b & b & 0 & 0 & 0 & 0 \\ (c-a) & -c & a & 0 & 0 & 0 \\ 0 & 0 & 0 & ab & 0 & 0 \\ 0 & 0 & 0 & -b & b & 0 \\ 0 & 0 & 0 & (c-a) & -c & a \end{bmatrix}$$

Hence finally, with  $\lambda_1 = \frac{1}{2}(1-\nu)$  and  $\lambda_2 = \frac{1}{2}(1+\nu)$  we obtain the stiffness matrix for the plane stress triangular element as shown in equation (3.47) below.

It is neither necessary nor economical to carry out these operations by hand; the computation of the element stiffness and, indeed, the entire computational process is easily programmed for the digital computer.

Computer 'packages' for finite element analysis of structures are highly developed, very powerful and readily available. Because of the comparatively heavy demands on computer storage, the use of the packages is generally confined to main-frame computers. A good example of a finite element system which is used very extensively is PAFEC.<sup>6</sup> The more important topics which should be studied in pursuing finite element analysis include: (1) shape (displacement) functions; (2) conforming and nonconforming elements; (3) isoparametric elements; and (4) automatic mesh generation.

$$k = \frac{Et}{2(1-\nu^2)ab} \begin{bmatrix} b^2 + \lambda_1(c-a)^2 & & & & & \\ -b^2 - \lambda_1 c(c-a) & b^2 + \lambda_1 c^2 & & & & \\ \lambda_1 a(c-a) & -\lambda_1 ac & \lambda_1 a^2 & & & \\ -\lambda_2 b(c-a) & \lambda_1 cb + \nu b(c-a) & -\lambda_1 ab & \lambda_1 b^2 + (c-a)^2 & & \\ \lambda_1 b(c-a) + \nu cb & -\lambda_2 bc & \lambda_1 ab & -\lambda_1 b^2 - c(c-a) & \lambda_1 b^2 + c^2 & \\ -\nu ab & \nu ab & 0 & a(c-a) & -ac & a^2 \end{bmatrix} \quad (3.47)$$

### 3.5 Moment distribution

#### 3.5.1 Introduction

Although the stiffness method, described in the previous section has the merit of simplicity, the solution of the equilibrium equations (3.31) is generally a matter for the digital computer since only for the simplest structures can a hand solution be contemplated. An alternative procedure which is eminently suitable for hand computation is the method of moment distribution which is essentially an iterative solution of the equations of equilibrium.

As in the general stiffness method, we first imagine all the degrees of freedom, joint rotations and joint translations, to be constrained. We ignore axial effects in members and consider flexure only. The constraints are imagined to be clamps applied to the joints to prevent rotation and translation. The forces required to effect the constraints are applied artificially and in the moment distribution processes these clamping forces are systematically released so as to allow the structure to achieve an equilibrium state. It is important to note that in the method as generally applied, the rotational joint restraints are relaxed by one process and the translational restraints by another. Finally the principle of superposition is used to combine the separate results.

It is necessary to assemble certain standard results before we can consider the actual process.

#### 3.5.2 Distribution factors, carry-over factors and fixed-end moments

For the time being we confine our attention to prismatic members. The treatment of nonuniform section members will be touched on later.

Standard member stiffnesses are required and these are illustrated in Figure 3.15. The member end forces are those required to produce the deflected forms shown. Diagrams (a) and (b) relate to rotation without translation (sway), and diagrams (c) and (d) relate to sway without rotation. The results in diagrams (a) and (c) may be deduced from the stiffness matrix in Equation (3.30). The other results may be obtained easily from elementary beam theory, e.g. in Figure 3.15(b), taking the origin of  $x$  at the left-hand end and  $y$  positive downwards:

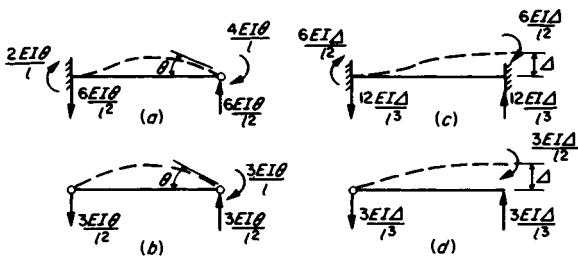

Figure 3.15

$EI d^2y/dx^2 = \frac{Mx}{l}$ , where  $M$  is the moment, to be determined, at the right-hand end,

$$EI dy/dx = \frac{M}{l} \frac{x^2}{2} + C_1,$$

$$= EI\theta \text{ for } x=l; \text{ hence } C_1 = EI\theta - M \frac{l}{2}$$

$$EIy = \frac{M}{l} \frac{x^3}{6} + \left( EI\theta - M \frac{l}{2} \right) x + C_2,$$

$$= 0 \text{ for } x=0; \text{ hence } C_2 = 0$$

$$= 0 \text{ for } x=l; \text{ hence, } M = \frac{3EI\theta}{l}$$

When loads are applied to members which are constrained at the joints, fixed-end moments are required to prevent the end rotations. This is another standard type of result which is required in the moment distribution method. Table 3.5 lists fixed-end moments for a selection of loading cases on uniform section beams. Again, these results may be obtained from elementary beam theory. It should be noted that the sign convention is that a moment is *positive* if tending to produce clockwise rotation of the end of the member at which it acts. This convention is different to, and should not be confused with, the sign convention for constructing bending moment diagrams which must be based on the curvature produced in the member.

As an illustration of the basic process, consider the structure ABC shown in Figure 3.11. This structure was analysed by the stiffness method previously. Joint B is considered to be clamped and thus a system of fixed-end moments is set up in member AB. The end moments in the members are shown in line 1 of Table 3.6. The constraining moment at joint B is seen to be  $Wl_1/8$  clockwise and we imagine this moment to be removed by the application of a moment  $-Wl_1/8$ . The subsequent rotation of joint B, anticlockwise through angle  $\theta$ , will develop moments in both members. Referring to Figure 3.15 the moments induced will be:

$$M_{BA} = -\frac{4EI\theta}{l_1}; M_{AB} = -\frac{2EI\theta}{l_1}$$

$$M_{BC} = -\frac{4EI\theta}{l_2}; M_{CB} = -\frac{2EI\theta}{l_2}$$

For equilibrium of joint B, the applied moment  $-Wl_1/8$  must equal the sum of the moments absorbed by the two members meeting at the joint:

$$-\frac{Wl_1}{8} = -\frac{4EI\theta}{l_1} - \frac{4EI\theta}{l_2} = -4EI\theta \left( \frac{1}{l_1} + \frac{1}{l_2} \right)$$

and it is seen that the moment is 'distributed' to the members in proportion to their  $I/l$  values.

Thus:

$$M_{BA} = \frac{-Wl_1}{8} \frac{I/l_1}{(I/l_1 + I/l_2)} = \frac{-Wl_1}{8} \left( \frac{l_2}{l_1 + l_2} \right)$$

and:

$$M_{BC} = \frac{-Wl_1}{8} \frac{I/l_2}{(I/l_1 + I/l_2)} = \frac{-Wl_1}{8} \left( \frac{l_1}{l_1 + l_2} \right)$$

The moments induced at A and C are from Figure 3.15, one-half of those induced at B and the factor of one-half is termed the *carry over* factor. This set of moments is shown in line 2 of Table 3.6.

Joint B is now 'in balance' and since it was the only joint which was clamped we have reached an equilibrium state and no further distribution of moments is required. The final set of

Table 3.6

Stage	Operation	$M_{AB}$	$M_{BA}$	$M_{BC}$	$M_{CB}$
1	Fixed-end moments	$-Wl_1/8$	$+Wl_1/8$	0	0
2	Distribution at B	$-\frac{Wl_1}{16} \left( \frac{l_2}{l_1+l_2} \right)$	$-\frac{Wl_1}{8} \left( \frac{l_2}{l_1+l_2} \right)$	$-\frac{Wl_1}{8} \left( \frac{l_1}{l_1+l_2} \right)$	$-\frac{Wl_1}{16} \left( \frac{l_1}{l_1+l_2} \right)$
3	Total moments	$-\frac{Wl_1}{16} \left( \frac{2l_1+3l_2}{l_1+l_2} \right)$	$\frac{Wl_1}{8(l_1+l_2)}$	$-\frac{Wl_1}{8(l_1+l_2)}$	$-\frac{Wl_1}{16(l_1+l_2)}$

moments is obtained in line 3 of Table 3.6, by the addition of lines 1 and 2. This result is the same as that obtained from pure stiffness considerations. It should be noted that the zero sum of moments  $M_{BA}$  and  $M_{BC}$  indicates that joint B is in rotational equilibrium.

Two further points should be noted before we consider the moment distribution process in more detail. Referring to Figure 3.16, of the three members connected at joint A, member AD is hinged at the end remote from A whereas the other two members are fixed. Since D is hinged no moment can exist there and hence there is no carry-over to D. Furthermore, the moment-rotation relationship is different for a member pinned

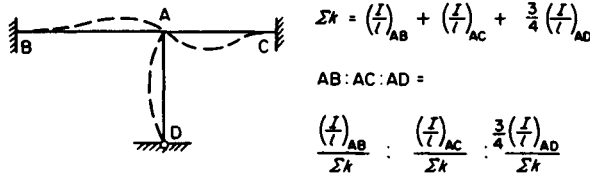

Figure 3.16 Distribution factors at typical joint

at the remote end, as may be seen by comparing Figures 3.15(a) and (b). In calculating distribution factors this is taken account of by taking  $\frac{3}{4}(I/I)$  for such members as compared with  $I/I$  for members fixed at the remote end.

### 3.5.3 Moment distribution without sway

As an example of a structure with two degrees of freedom of joint rotation and no sway, consider the frame shown in Figure 3.17,  $EI$  (beams) =  $3 \times EI$  (columns).

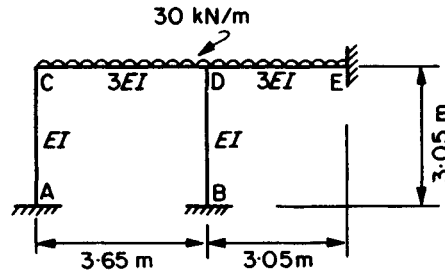

Figure 3.17

Table 3.7 Moment distribution for frame shown in Figure 3.17

Joint	A	C	D	B	E			
Distribution factors end moments	AC	0.285 CA	0.715 CD	0.386 DC	0.154 DB	0.460 DE	BD	ED
(1) Fixed-end moments			-33.3	+33.3		-23.3		+23.3
(2) Distribution at C		+9.5	+23.8					
(3) Carry-over to A and D	+4.75			+11.9				
(4) Distribution at D				-8.45	-3.38	-10.07		
(5) Carry-over to C, B and E			-4.23				-1.69	-5.04
(6) Distribution at C		+1.20	+3.03					
(7) Carry-over to A and D	+0.60			+1.52				
(8) Distribution at D				-0.59	-0.23	-0.70		
(9) Carry-over to C, B and E			-0.30				-0.12	-0.35
(10) Distribution at C		+0.09	+0.21					
(11) Carry-over to A and D	+0.05			+0.11				
(12) Distribution at D				-0.04	-0.02	-0.05		
(13) Carry-over to C, B and E				May be neglected				
(14) Total moments (kNm)	+5.40	+10.79	-10.79	+37.75	-3.63	-34.12	-1.81	+17.91

3/18 Theory of structures

The fixed-end moments are,  $(wl^2/12)$ ,

$$M_{FCD} = -30 \times \frac{3.65^2}{12}; M_{FDC} = +30 \times \frac{3.65^2}{12} = 33.3 \text{ kNm}$$

$$F_{FDE} = -30 \times \frac{3.05^2}{12}; M_{FED} = +30 \times \frac{3.05^2}{12} = 23.3 \text{ kNm}$$

and the distribution factors are:

$$\text{at C, CD:CA} = \frac{3/3.65}{(1/3.05) + (3/3.65)} : \frac{1/3.05}{(1/3.05) + (3/3.65)} = 0.715:0.285$$

at D, DC:DB:DE =

$$\frac{3/3.65}{(3/3.65) + (1/3.05) + (3/3.05)} : \frac{1/3.05}{(3/3.65) + (1/3.05) + (3/3.05)} : \frac{3/3.05}{(3/3.65) + (1/3.05) + (3/3.05)}$$

$$= 0.386:0.154:0.460$$

The moment distribution is carried out in Table 3.7. It should be noted that after each distribution at a joint the distributed moments are underlined to indicate that the joint is balanced at that stage. At step 4, the out-of-balance moment to be distributed at D is  $+33.3 + 11.9 - 23.3 = +21.9$ ; hence the distributed moments should total  $-21.9$ .

3.5.4 Moment distribution with sway

This process will be illustrated with reference to Example 3.3 (page 3/9), for which the structure is shown in Figure 3.9. We first ignore any horizontal movement (sway) of the joints B and C and carry out a moment distribution.

The fixed-end moments are  $wl^2/12 = \pm 40 \text{ kNm}$ ; and the distribution factors are:

$$BA:BC = \frac{1}{3} : \frac{2}{3}$$

$$CB:CD = \frac{2}{3} : \frac{1}{3} \text{ (noting } \frac{2}{3} // l \text{ for CD)}$$

The result of this (no sway) moment distribution is given in line 3 of Table 3.8. We now consider the horizontal equilibrium of the beam BC, Figure 3.18(a), and find that a force  $F_1$  is required to maintain equilibrium.  $F_1$  may be calculated by evaluating the horizontal shear forces at the tops of the columns as follows:

$$F_1 = 120 + \frac{(20 + 10)}{4} - \frac{20}{3} = 120.8 \text{ kN}$$

This force cannot exist in practice and what happens is that the beam BC deflects to the right and a new set of bending moments is set up with the effect that the out-of-balance horizontal force  $F_1$  is removed. We consider the effect of this sway separately. Referring to Figure 3.18(b), a movement to the right of  $\Delta$ , without joint rotation, requires column moments as shown. From Figure 3.15(c) and (d), these column moments are,

$$M_{FBA} = M_{FAB} = -6 \left( \frac{EI}{l^2} \right) \Delta_{AB}$$

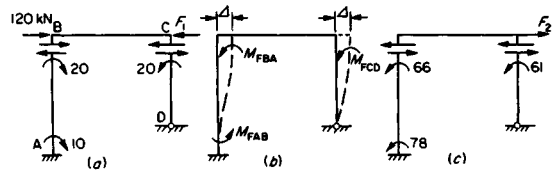

Figure 3.18

$$M_{FCD} = -3 \left( \frac{EI}{l^2} \right) \Delta_{CD} \text{ (note } M_{FDC} = 0)$$

We cannot evaluate these moments unless  $\Delta$  is known but we could proceed with an arbitrary value of  $\Delta$ , and carry out a distribution to produce rotational equilibrium of the joints B and C. In fact, it is seen that any arbitrary values of moments can be used providing these are in the correct proportions between the two columns. The ratio in this example is:

$$AB:CD = \left( \frac{I}{l^2} \right)_{AB} : \frac{1}{2} \left( \frac{I}{l^2} \right)_{CD}$$

If we adopt

$$M_{FBA} = M_{FAB} = -90$$

and

$$M_{FCD} = -80$$

the moments are in the correct proportion. A second moment distribution is now carried out, using these values of fixed-end moments, and the result is shown in line 1 of Table 3.8. This set of moments is consistent with an applied horizontal force  $F_2$ , Figure 3.18(c), and:

$$F_2 = \frac{66 + 78}{4} + \frac{61}{3} = 56.3 \text{ kN}$$

Table 3.8

	Joint	A	B	C		
End moments		AB	BA	BC	CB	CD
(1)	Arbitrary sway	-78	-66	+66	+61	-61
(2)	Corrected $[(1) \times \lambda]$	-167	-141	+141	+131	-131
(3)	No sway moments	+10	+20	-20	+20	-20
(4)	Final moments [(2) + (3)]	-157	-121	+121	+151	-151

Now  $F_2$  has to be scaled to equal  $F_1$  and the scaling factor is  $F_1/F_2 = \lambda = 120.8/56.3 = 2.14$ .

The corrected moments are given in line 2 of Table 3.8 and the final moments are in line 4 obtained by adding lines 2 and 3.

3.5.5 Additional topics in moment distribution

Space has permitted only a brief introduction to the method of moment distribution. Additional topics which should be studied by reference to the standard texts,<sup>3,4</sup> are as follows:

- (1) Frames with multiple degrees of freedom for sway. These are handled by carrying out an arbitrary sway distribution

for each sway in turn. Equilibrium conditions are then used to relate the out-of-balance forces and obtain the correction factors for each sway mode.

- (2) *Treatment of symmetry.* In cases of symmetry the moment distribution process can be considerably shortened. Two cases arise and should be studied, systems in which it is known that the final set of moments is symmetrical and systems in which the final moments form an anti-symmetrical system.
- (3) *Nonprismatic members.* If the flexural rigidity ( $EI$ ) of a member varies within its length, then the effect is to change the values of end stiffnesses, carry-over factor and fixed end moments. A suitable general method for handling this situation is to evaluate end flexibilities by the use of Simpson's rule and then convert the flexibilities into stiffnesses.

### 3.6 Influence lines

#### 3.6.1 Introduction and definitions

It is frequently necessary to consider loads which may occupy variable positions on a structure. For example, in bridge design it is important to determine the maximum effects due to the passage of a specified train or system of loads. In other cases the total load on a structure may be comprised of different loads which may be applied in various combinations and this again is a problem of variability of load or load position. The effect of varying a load position may be studied with the help of *influence lines*.

An influence line shows the variation of some resultant action or effect such as bending moment, shear force, deflection, etc. at a particular point as a unit load traverses the structure. It is important to observe that the effect considered is at a fixed position, e.g. *bending moment at C*, and that the independent variable in the influence line diagram is *the load position*. The following is a summary of influence line theory. For a more detailed treatment the reader should consult Jenkins.<sup>1</sup>

#### 3.6.2 Influence lines for beams

Consider the simply-supported beam AB, Figure 3.19, carrying a single unit load occupying a variable position distant  $y$  from A. We require to obtain influence lines for bending moment and shear force at a fixed point X distant  $a$  from A and  $b$  from B.

If the unit load lies between X and B:

$$M_x = R_A \cdot a = 1 \frac{(l-y)}{l} a \quad (3.48)$$

If the unit load acts between A and X:

$$M_x = R_B \cdot b = 1 \cdot y/l \cdot b \quad (3.49)$$

Equations (3.48) and (3.49) are linear in  $y$  and when plotted in the regions to which they relate, form a triangle as shown in Figure 3.19(b). We note that, in both cases, substitution of  $y = a$  gives  $M_x = 1 \cdot ab/l$ . Thus the influence line for  $M_x$  is a triangle with a peak value  $ab/l$  at the section X.

Turning now to the influence line for shearing force at X. For unit load between X and B:

$$S_x = R_A = \frac{l-y}{l} \quad (3.50)$$

(and now we have implied a sign convention for shear force

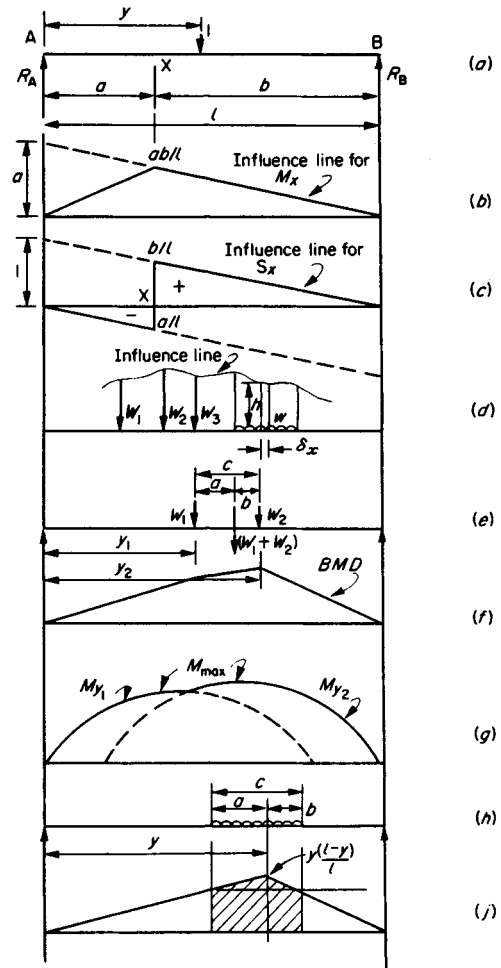

Figure 3.19 Influence lines and related diagrams for simply supported beams

namely that  $S_x$  is positive if the resultant force to the left of the section is upwards).

Where  $y = a$ ,  $S_x = b/l$

For unit load between A and X:

$$S_x = -R_B = -y/l \quad (3.51)$$

when  $y = a$ ,  $S_x = -a/l$

We note that Equations (3.50) and (3.51) give different values of  $S_x$  for  $y = a$  and moreover the signs are opposite. This means that the shear force influence line contains a discontinuity at X as shown in Figure 3.19(c).

In using influence lines with a given system of loads and having determined the locations of the loads on the span, the total effect is evaluated as:

$$\sum (W \times \text{ordinate}), \text{ for concentrated loads} \quad (3.52)$$

and:

3/20 Theory of structures

$$\int whdx = w \text{ (area under influence line)} \quad (3.53)$$

for distributed loads (Figure 3.19(d)).

The maximum effect produced at a given position is of interest in the design process. In the case of concentrated loads, from Equation (3.52), this is obtained when:

$$\sum(W \times \text{ordinate}) \text{ is a maximum}$$

The process of locating the loads to produce the maximum value is best done by trial and error. It follows from the straight-line nature of a bending moment diagram due to concentrated loads, that the maximum bending moment at a section will be obtained when one of the loads acts at the section. This may be illustrated by reference to the two-load system shown at (e) in Figure 3.19. The shape of the bending moment diagram is as shown at (f) and at (g) is drawn a diagram which shows the maximum value of bending moment at any section in the beam. This is the *maximum bending moment envelope*  $M_{max}$ , which is seen to consist of two intersecting parabolic curves  $M_{y1}$  and  $M_{y2}$ .

The curve  $M_{y1}$  represents the maximum bending moment at all sections in the beam when this is obtained with load  $W_1$  placed at the section. The curve  $M_{y2}$  represents the maximum bending moment at all sections in the beam when this is obtained with load  $W_2$  at the section. It is seen that  $W_1$  should be placed at the section towards the left-hand end of the beam, and  $W_2$  at the section towards the right-hand end of the beam.

The expressions for  $M_{y1}$  and  $M_{y2}$  are as follows:

$$\left. \begin{aligned} M_{y1} &= (W_1 + W_2) \frac{y_1}{l} (l - y_1 - a) \\ M_{y2} &= (W_1 + W_2) \frac{(l - y_2)}{l} (y_2 - b) \end{aligned} \right\} \quad (3.54)$$

In the case of a distributed load which has a length greater than the span, then for an influence line of type (b) in Figure 3.19, the whole span would be loaded, whereas for an influence line of type (c) one would place the left-hand end of the load at X thus avoiding the introduction of a negative effect on the maximum positive value. For a short distributed load, as at (h), for maximum effect at y, the load must be placed so that the shaded area in (j) is a maximum.

The rule for this is:

$$y/l = a/c \quad (3.55)$$

3.6.3 Influence lines for plane trusses

In the analysis of plane trusses, the influence line is useful in representing the variations in forces in members of the truss.

Figure 3.20(a) shows a Warren girder AB of span 20 m. For the unit load acting at any of the lower chord joints, the force in member 1 is:

$$P_1 = \frac{AR_A}{2\sqrt{3}}$$

The peak value occurs when the unit load is at C, and thus:

$$P_{1max} = \frac{2}{\sqrt{3}} \times \frac{4}{5} \times 1 = \frac{8}{5\sqrt{3}}$$

The influence line for  $P_1$  is shown at (b).

For member 2, if the unit load lies between A and E, we take:

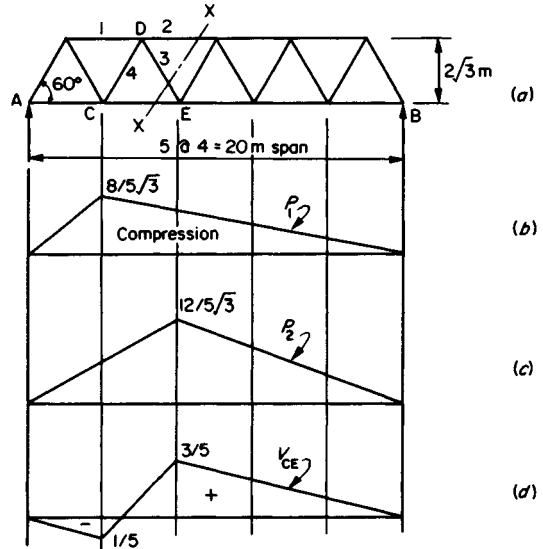

Figure 3.20 Influence lines for plane truss

$$P_2 = \frac{12R_B}{2\sqrt{3}}$$

or, if the unit load lies between E and B we take:

$$P_2 = \frac{8R_A}{2\sqrt{3}}$$

The result is a triangle with peak value  $12/5\sqrt{3}$  at E, as shown in diagram (c).

It should be noted that both the  $P_1$  and  $P_2$  influence lines indicate compression for all positions of the unit load.

For members 3 and 4 it is useful to note that these members carry the vertical shear force in the panel CE, and we proceed by drawing the influence line for  $V_{CE}$  as at (d).

Considering now the force in member 3 and the section XX in diagram (a), it is clear that the relationship is:

$$P_3 = \frac{V_{CE}}{\sin 60^\circ}$$

and that  $P_3$  is tensile when  $V_{CE}$  is positive and compressive when  $V_{CE}$  is negative.

3.6.4 Influence lines for statically indeterminate structures

The use of influence lines in representing the effects of variable-position loads in statically determinate beams and trusses has been outlined. The concept is, of course, of general application. When dealing with statically indeterminate structures it is convenient to introduce some additional theorems to assist the analysis. It is possible to relate influence line shapes to deflected shapes of structures under particular forms of applied force. This involves an application of Mueller-Breslau's principle, which we shall look at in this section. The application of this principle can take the form of a model analysis, to which a simple form or model of the structure is made and particular distortions of the model produce scaled versions of influence lines.

With the enormous increase in computing power now available there is little need to use models in this way and it is generally more economical to produce influence lines by computer. It should be noted that it is always possible to construct influence lines by repeated analysis of the structure under a unit applied load, changing the load position for each analysis and thus producing a succession of ordinates to the influence line sought. This latter approach will be illustrated in section 3.6.8.

We now look at two important theorems concerned with influence lines.

### 3.6.5 Maxwell's reciprocal theorem

Consider the propped cantilever shown in Figure 3.21 to be subjected to a load  $W$  at A, producing displacements  $f_{11}$  and  $f_{21}$  as shown at (a), and then separately to be subjected to a moment  $M$  at B producing displacements  $f_{12}$  and  $f_{22}$  as at (b). Assuming a linear load-displacement relationship we may use the principle of superposition and obtain the combined effects of  $W$  and  $M$  by adding (a) and (b). Clearly it will be immaterial in which order the forces are applied. Applying  $W$  first and then  $M$ , the work done by the loads will be:

$$\left(\frac{1}{2}Wf_{11}\right) + \left(\frac{1}{2}Mf_{22} + Wf_{12}\right) \tag{3.56}$$

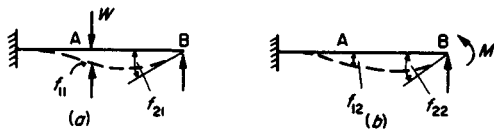

Figure 3.21

The first bracket in Equation (3.56) contains the work done during the application of  $W$  and the second bracket the work done (by both  $M$  and  $W$ ) during the application of  $M$ .

In a similar way, if the order is reversed, the work done is:

$$\left(\frac{1}{2}Mf_{22}\right) + \left(\frac{1}{2}Wf_{11} + Mf_{21}\right) \tag{3.57}$$

From Equations (3.56) and (3.57) it is evident that:

$$Wf_{12} = Mf_{21} \tag{3.58}$$

If the applied actions are taken to have unit values, then Equation (3.58) simplifies to:

$$f_{12} = f_{21} \tag{3.59}$$

Equation (3.59) is a statement of Maxwell's reciprocal theorem. A more general theorem, of which Maxwell's is a special case, is due to Betti. This latter theorem states that if a system of forces  $P_i$  produces displacements  $p_i$  at corresponding positions and another set of forces  $Q_j$ , at similar positions to  $P_j$ , produces displacements  $q_j$ , then:

$$P_1q_1 + P_2q_2 + \dots + P_nq_n = Q_1p_1 + Q_2p_2 + \dots + Q_n p_n \tag{3.60}$$

### 3.6.6 Mueller-Breslau's principle

This principle is the basis of the indirect method of model analysis. It is developed from Maxwell's theorem as follows. Consider the two-span continuous beam shown in Figure 3.22(a). On removal of the support at C and the application of a unit load at C, a deflected shape, shown dotted in Figure

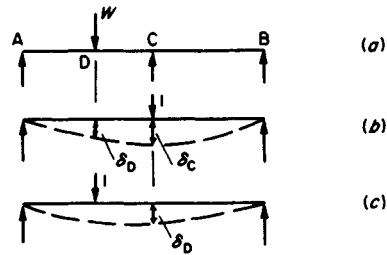

Figure 3.22

3.22(b), is obtained. If a unit load now occupies any arbitrary position D, as at (c), then from Maxwell's theorem the deflection at C will be  $\delta_D$ . In other words, the deflected form (b) is the influence line for deflection of C.

Now the force at C to move C through  $\delta_C = 1$

Hence, the force at C to move C through  $\delta_D = 1 \times \delta_D/\delta_C$ .

If a unit load acts at D, producing a deflection  $\delta_D$  at C, then the upwards force needed to restore C to the level of AB is  $1 \times \delta_D/\delta_C$ . Hence, the reaction at C for unit load at D is  $1 \times \delta_D/\delta_C$ . Since D is an arbitrary point in the beam then it is seen that the deflected shape due to unit load at C, Figure 3.22(b), is to some scale, the influence line for  $R_C$ . The scale of the influence line is determined from the knowledge that the actual ordinate at C should equal unity. Hence, the ordinates should all be divided by  $\delta_C$ .

This result leads to Mueller-Breslau's principle which may be stated as follows:

'The ordinates of the influence line for a redundant force are equal to those of the deflection curve when a unit load replaces the redundancy, the scale being chosen so that the deflection at the point of application of the redundancy represents unity.'

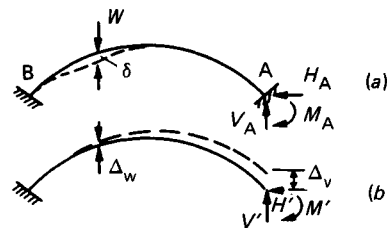

Figure 3.23

### 3.6.7 Application to model analysis

Consider the fixed arch shown in Figure 3.23(a). The arch has three redundancies which may be taken conveniently as  $H_A$ ,  $V_A$  and  $M_A$ . We make a simple model of the arch to a chosen linear scale and pin this to a drawing board. End B is fixed in position and direction and the undistorted centreline is transferred to the drawing paper. We then impose a purely vertical displacement  $\Delta_w$  at A and transfer the distorted centreline to the drawing paper. The distortion produced will require force actions at A,  $V'$ ,  $H'$  and  $M'$ . Let the displacement of a typical load point be  $\Delta_w$ . Applying Equation (3.60) to the two systems of forces:

$$V_A(\Delta_w) + H_A(0) + M_A(0) + W(\Delta_w) = V'(0) + H'(0) + M'(0) + 0(\delta)$$

Hence:

$$V_A \Delta_w + W \Delta_w = 0$$

and if  $W = 1$ :

$$V_A = \frac{-\Delta_w}{\Delta_v} \quad (3.61)$$

Similarly, we impose a *purely* horizontal displacement  $\Delta_H$  and obtain:

$$H_A = \frac{-\Delta'_w}{\Delta_H} \quad (3.62)$$

then a pure rotation  $\theta$  and obtain:

$$M_A = -\frac{\Delta''_w}{\theta} \quad (3.63)$$

In Equations (3.62) and (3.63) the displacements  $\Delta'_w$  and  $\Delta''_w$  represent the arch displacements due to the imposed horizontal and rotational displacements respectively. In each case the deflected shape, suitably scaled, gives the influence line for the corresponding redundancy.

3.6.7.1 Sign convention

The negative sign in Equations (3.61) to (3.63) leads to the following convention for signs. On the assumption that a reaction is positive if in the direction of the imposed displacement, then a load  $W$  will give a positive value of the reaction if the influence line ordinate at the point of application of the load is opposite to the direction of the load. This is evident in Figure 3.23(b) where the upward deflection  $\Delta_w$ , being opposed to the direction of the load  $W$ , is consistent with a positive (upwards) direction for  $V_A$ .

3.6.7.2 Scale of the model

It should be noted that when using relationships (3.61) and (3.62) the ratios  $\Delta_w/\Delta$  and  $\Delta'_w/\Delta_H$  are dimensionless and thus the linear scale of the model does not affect the influence line ordinates. On the other hand, when using Equation (3.63) in obtaining an influence line for bending moment,  $\Delta_w/\theta$  has the dimensions of length and thus the model displacements must be multiplied by the linear scale factor.

In performing the model analysis, quite large displacements can be used providing the linear relation between load and displacement is maintained. Hence, the indirect method is sometimes called the 'large displacement' method.

3.6.8 Use of the computer in obtaining influence lines

With adequate computing facilities it is generally more economical to proceed directly to the computation of influence line ordinates by the analysis of the structure under a unit load, the unit load occupying a succession of positions. The actual method of analysis is immaterial but for bridge-type structures often the flexibility method offers some advantage especially if the structural members are 'nonprismatic'. An example of this type of computation is shown in Figure 3.24 where influence lines for bending moments at the interior supports of a five-span continuous beam are given. The beam is taken to be uniform in section over its length and, due to the symmetry of the spans, unit load positions need only be taken over one-half of the structure as shown.

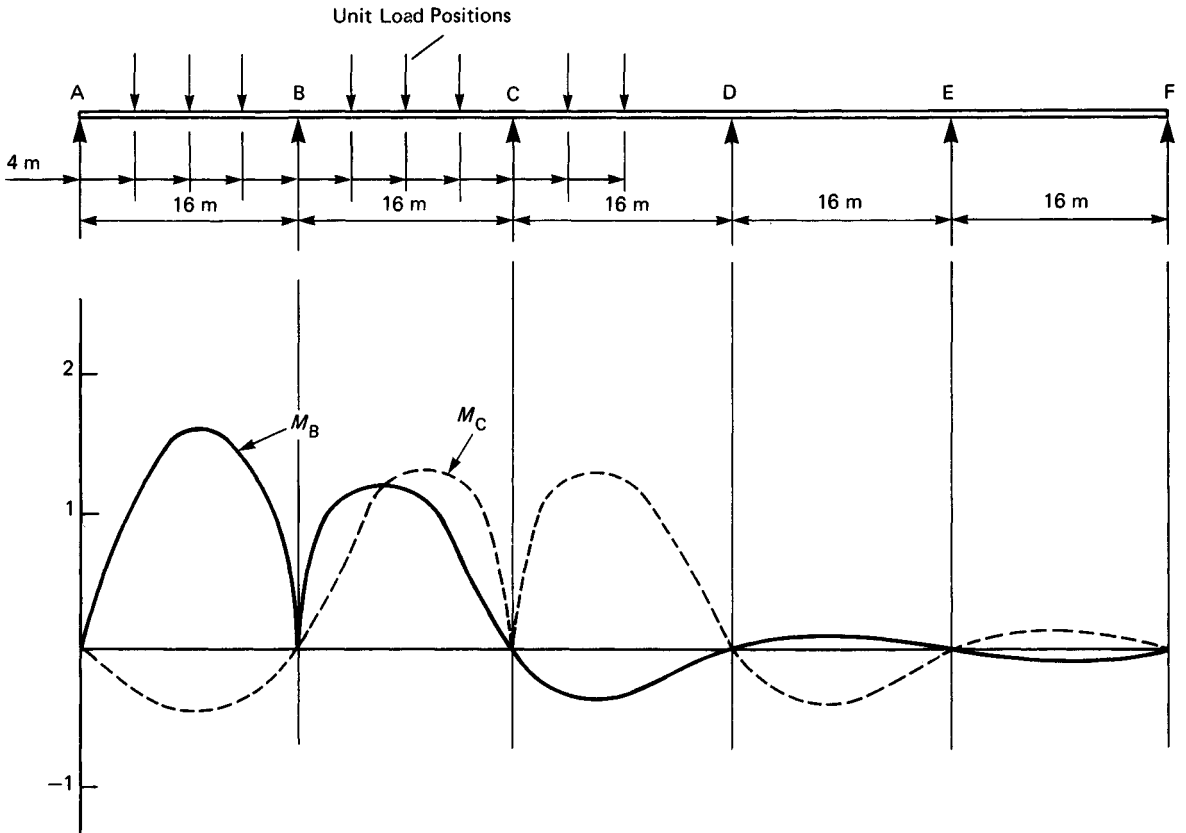

Figure 3.24 Influence lines for bending moments in a continuous beam obtained by computer analysis

### 3.7 Structural dynamics

#### 3.7.1 Introduction and definitions

Structural vibrations result from the application of *dynamic* loads, i.e. loads which vary with time. Loads applied to structures are often time-dependent although in most cases the rate of change of load is slow enough to be neglected and the loads may be regarded as *static*. Certain types of structure may be susceptible to dynamic effects; these include structures designed to carry moving loads, e.g. bridges and crane girders, and structures required to support machinery. One of the most severe and destructive sources of dynamic disturbance of structures is, of course, the earthquake.

The dynamic behaviour of structures is generally described in terms of the displacement–time characteristics of the structure, such characteristics being the subject of vibration analysis. Before considering methods of analysis it is helpful to define certain terms used in dynamics.

- (1) *Amplitude* is the maximum displacement from the mean position.
- (2) *Period* is the time for one complete cycle of vibration.
- (3) *Frequency* is the number of vibrations in unit time.
- (4) *Forced vibration* is the vibration caused by a time-dependent disturbing force.
- (5) *Free vibrations* are vibrations after the force causing the motion has been removed.
- (6) *Damping*. In structural vibrations, damping is due to: (a) internal molecular friction; (b) loss of energy associated with friction due to slip in joints; and (c) resistance to motion provided by air or other fluid (drag). The type of damping usually assumed to predominate in structural vibrations is termed *viscous* damping in which the force resisting motion is proportional to the velocity. Viscous damping adequately represents the resistance to motion of the air surrounding a body moving at low speed and also the internal molecular friction.
- (7) *Degrees of freedom*. This is the number of independent displacements or *coordinates* necessary to completely define the deformed state of the structure at any instant in time. When a single coordinate is sufficient to define the position of any section of the structure, the structure has a *single degree of freedom*. A continuous structure with a distributed mass, such as a beam, has an infinite number of degrees of freedom. In structural dynamics it is generally satisfactory to transform a structure with an infinite number of degrees of freedom into one with a finite number of freedoms. This is done by adopting a *lumped mass* representation of the structure, as in Figure 3.25. The total mass of the structure is considered to be *lumped* at specified points in the structure and the motion is described in terms of the displacements of the lumped masses. The accuracy of the analysis can be improved by increasing the number of lumped masses. In most cases sufficiently accurate results can be obtained with a comparatively small number of masses.

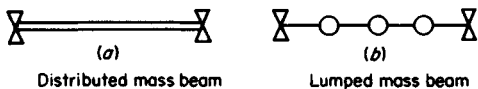

Figure 3.25

#### 3.7.2 Single degree of freedom vibrations

The portal frame shown in Figure 3.26 is an example of a structure with a single degree of freedom providing certain assumptions are made. If it is assumed that the entire mass of

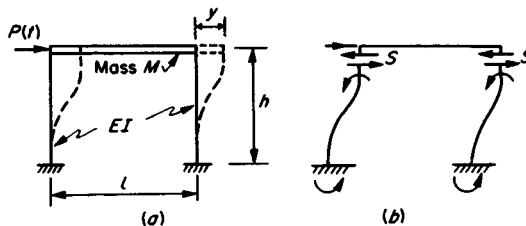

Figure 3.26

the structure (*M*) is located in the girder and that the girder has an infinitely large flexural rigidity and further, that the columns have infinitely large extensional rigidities, then the displacement of the mass *M* resulting from the application of an exciting force *P*(*t*), is defined by the transverse displacement *y*. The girder moves in a purely horizontal direction restrained only by the flexure of the columns.

From Newton's second law of motion:

$$\text{Force} = \text{mass} \times \text{acceleration}$$

i.e.:

$$\sum P = M\ddot{y} \tag{3.64}$$

Now from Figure 3.26(b), the force resisting motion is:

$$\begin{aligned} 2S &= 2 \left( \frac{12EIy}{h^3} \right) \\ &= 24 \frac{EIy}{h^3} \end{aligned} \tag{3.65}$$

Thus Equation (3.64) becomes:

$$P(t) - 24 \frac{EIy}{h^3} = M\ddot{y}$$

or:

$$M\ddot{y} + 24 \frac{EIy}{h^3} = P(t) \tag{3.66}$$

If the effect of damping is included then the equation of motion, Equation (3.66) is modified by the inclusion of a term *c* $\dot{y}$  where *c* is a constant. It should be noted that since the effect of damping is to resist the motion, then the term *c* $\dot{y}$  is added to the left-hand side of Equation (3.66). Thus:

$$M\ddot{y} + c\dot{y} + 24 \frac{EIy}{h^3} = P(t) \tag{3.67}$$

Equation (3.67) may be generalized for any single degree of freedom structure by observing that the stiffness of the structure, i.e. force required for unit displacement horizontally, is given by:

$$k = 24 \frac{EI}{h^3} \tag{3.68}$$

Combining Equations (3.67) and (3.68) we obtain the general single degree of freedom equation of motion:

$$M\ddot{y} + c\dot{y} + ky = P(t) \tag{3.69}$$

3/24 Theory of structures

If in Equation (3.69)  $P(t) = 0$ , we have a state of *free vibration* of the structure. The governing equation becomes:

$$M\ddot{y} + c\dot{y} + ky = 0 \tag{3.70}$$

The situation envisaged by Equation (3.70) would arise if the beam were given a horizontal displacement and then released. The resulting vibrations would depend on the amount of damping present, measured by the coefficient  $c$ .

The solution of Equation (3.70) is:

$$y = A_1 e^{\lambda_1 t} + A_2 e^{\lambda_2 t} \tag{3.71}$$

where  $A_1$  and  $A_2$  are the constants of integration, to be evaluated from initial conditions, and  $\lambda_1$  and  $\lambda_2$  are the roots of the auxiliary equation:

$$M\lambda^2 + c\lambda + k = 0 \tag{3.72}$$

or, substituting:

$$\left. \begin{aligned} p^2 &= k/M \\ \text{and} \\ 2n &= c/M \end{aligned} \right\} \tag{3.73}$$

Equation (3.72) becomes:

$$\lambda^2 + 2n\lambda + p^2 = 0 \tag{3.74}$$

Hence:

$$\lambda = -n \pm \sqrt{(n^2 - p^2)} \tag{3.75}$$

Four cases arise:

Case 3.1  $p^2 < n^2$

Here  $(n^2 - p^2)$  is always positive and  $< n^2$  and thus  $\lambda_1$  and  $\lambda_2$  are real and negative.

Equation (3.71) takes the form:

$$y = e^{-nt}(A_1 e^{\sqrt{(n^2 - p^2)}t} + A_2 e^{-\sqrt{(n^2 - p^2)}t}) \tag{3.76}$$

The relationship between  $y$  and  $t$  of Equation (3.76) is shown in Figure 3.27(a) and it is seen that the displacement  $y$  gradually returns to zero, no vibrations taking place.

Now, since  $n^2 > p^2$ , then:

$$\frac{c^2}{4M^2} > \frac{k}{M}$$

or

$$c > 2\sqrt{(Mk)} \tag{3.77}$$

A structure exhibiting these characteristics is said to be *over-damped*.

Case 3.2  $p^2 = n^2$

From Equation (3.75),  $\lambda = -n$  (twice) and hence,

$$y = e^{-nt}(A_1 + A_2 t) \tag{3.78}$$

Again, no vibrations result and Equation (3.78) has the form shown in Figure 3.27(a).

From Equation (3.73) the value of  $c$  for this condition is given by:

$$c_c = 2\sqrt{(Mk)} \tag{3.79}$$

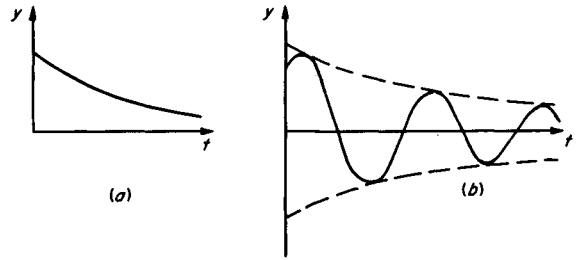

Figure 3.27

This is termed *critical damping* and the critical damping coefficient  $c_c$  is the value of the damping coefficient at the boundary between vibratory and nonvibratory motion. The critical damping coefficient is a useful measure of the damping capacity of a structure. The damping coefficient of a structure is usually expressed as a percentage of the critical damping coefficient.

Case 3.3  $p^2 > n^2$

Here  $c < c_c$  and the structure is *underdamped*.

From Equation (3.75),  $\lambda = -n \pm i\sqrt{(p^2 - n^2)}$

Hence:

$$y = e^{-nt}(A_1 e^{i\sqrt{(p^2 - n^2)}t} + A_2 e^{-i\sqrt{(p^2 - n^2)}t})$$

or, putting:

$$(p^2 - n^2) = q^2$$

$$y = e^{-nt}(A_1 e^{iqt} + A_2 e^{-iqt})$$

or

$$y = e^{-nt}(A \cos qt + B \sin qt) \tag{3.80}$$

A typical displacement–time relationship for this condition is shown in Figure 3.27(b).

An alternative form for Equation (3.80) is:

$$y = Ce^{-nt} \sin (qt + \beta) \tag{3.81}$$

where  $C$  and  $\beta$  are new arbitrary constants

$$\text{The period } T = \frac{2\pi}{q} = \frac{2\pi}{p\sqrt{\{1 - (n/p)^2\}}}$$

The period is constant but the amplitude decreases with time. The decay of amplitude is such that the ratio of amplitudes at intervals equal to the period is constant, i.e.:

$$\frac{y(t)}{y(t+T)} = e^{nT}$$

and  $\log e^{nT} = nT = \delta$

$\delta$  is called the *logarithmic decrement*, and is a useful measure of damping capacity.

The percentage critical damping

$$= 100 \frac{c}{c_c}$$

$$= 100 \frac{\delta}{pT}$$

This is of the order of 4% for steel frames and 7% for concrete frames.

Case 3.4  $c=0$

In the absence of damping, Equation (3.70) becomes:

$$M\ddot{y} + ky = 0 \tag{3.82}$$

The solution of which is:

$$y = A_1 e^{\lambda_1 t} + A_2 e^{\lambda_2 t}$$

where, from Equation (3.72):

$$\lambda_1 = ip$$

$$\lambda_2 = -ip$$

Thus:

$$y = A \sin pt + B \cos pt \tag{3.83}$$

The period is,  $T = \frac{2\pi}{p}$

where  $p$  is the *natural circular frequency*

The *natural frequency* is  $f = \frac{1}{T} = \frac{p}{2\pi}$

### 3.7.3 Multi-degree of freedom vibrations

Vibration analysis of systems with many degrees of freedom is a complex subject and only a brief indication of one useful method will be given here. For a more comprehensive and detailed treatment, the reader should consult one of the standard texts.<sup>7</sup>

For a system represented by lumped masses, the governing equations emerge as a set of simultaneous ordinary differential equations equal in number to the number of degrees of freedom. Mathematically the problem is of the *eigenvalue* or *characteristic value* type and the solutions are the *eigenvalues* (frequencies) and the *eigenvectors* (modal shapes). We shall consider the evaluation of mode shapes and fundamental, undamped, frequencies by the process of matrix iteration using the flexibility approach (see page 3/6). The method to be described, leads automatically to the lowest frequency, the fundamental, this being the one of most interest from a practical point of view. The alternative method using a stiffness matrix approach leads to the highest frequency.

Consider the simply-supported, uniform cross-section beam shown in Figure 3.28(a). The mass/unit length is  $w$  and we will regard the total mass of the beam to be lumped at the quarter-span points as shown in Figure 3.28(b). We may ignore the end

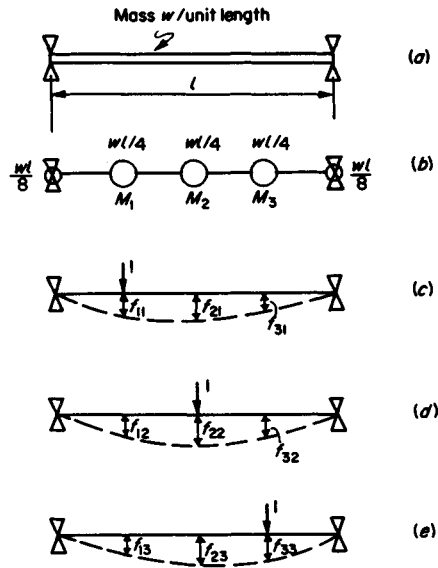

Figure 3.28

masses  $w/8$  since they are not involved in the motion, and consider the three masses

$$M_1 = M_2 = M_3 = w/4.$$

The appropriate flexibilities,  $f_{ij}$ , are shown at (c), (d) and (e). Using the flexibility method previously described, we may obtain a flexibility matrix as follows:

$$F = \begin{bmatrix} f_{11} & f_{12} & f_{13} \\ f_{21} & f_{22} & f_{23} \\ f_{31} & f_{32} & f_{33} \end{bmatrix} = \frac{l^3}{256EI} \begin{bmatrix} 3.00 & 3.67 & 2.33 \\ 3.67 & 5.33 & 3.67 \\ 2.33 & 3.67 & 3.00 \end{bmatrix} \tag{3.84}$$

It should be noted that  $f_{ij}$  is the displacement of mass  $M_i$  due to unit force acting at  $M_j$ . Thus, if the forces acting at the positions of the lumped masses are  $F_{1,2,3}$  and the corresponding displacements are  $y_{1,2,3}$ , then:

$$\left. \begin{aligned} y_1 &= f_{11}F_1 + f_{12}F_2 + f_{13}F_3 \\ y_2 &= f_{21}F_1 + f_{22}F_2 + f_{23}F_3 \\ y_3 &= f_{31}F_1 + f_{32}F_2 + f_{33}F_3 \end{aligned} \right\} \tag{3.85}$$

For free, undamped vibrations,  $F_i$  is an inertia force  $= -M_i \ddot{y}_i$ .

Thus:

$$\left. \begin{aligned} y_1 + f_{11}M_1\ddot{y}_1 + f_{12}M_2\ddot{y}_2 + f_{13}M_3\ddot{y}_3 &= 0 \\ y_2 + f_{21}M_1\ddot{y}_1 + f_{22}M_2\ddot{y}_2 + f_{23}M_3\ddot{y}_3 &= 0 \\ y_3 + f_{31}M_1\ddot{y}_1 + f_{32}M_2\ddot{y}_2 + f_{33}M_3\ddot{y}_3 &= 0 \end{aligned} \right\} \tag{3.86}$$

The solutions take the form:

$$y_i = \delta_i \cos(pt + a) \tag{3.87}$$

Hence:

$$\ddot{y}_i = -p^2 y_i \tag{3.88}$$

Thus, Equations (3.86) become:

$$\left. \begin{aligned} \delta_1 - f_{11} M_1 p^2 \delta_1 - f_{12} M_2 p^2 \delta_2 - f_{13} M_3 p^2 \delta_3 &= 0 \\ \delta_2 - f_{21} M_1 p^2 \delta_1 - f_{22} M_2 p^2 \delta_2 - f_{23} M_3 p^2 \delta_3 &= 0 \\ \delta_3 - f_{31} M_1 p^2 \delta_1 - f_{32} M_2 p^2 \delta_2 - f_{33} M_3 p^2 \delta_3 &= 0 \end{aligned} \right\} \quad (3.89)$$

or:

$$\Delta = p^2 \mathbf{FM} \Delta \quad (3.90)$$

where:

$$\Delta = \begin{bmatrix} \delta_1 \\ \delta_2 \\ \delta_3 \end{bmatrix}; \quad \mathbf{M} = \begin{bmatrix} M_1 & 0 & 0 \\ 0 & M_2 & 0 \\ 0 & 0 & M_3 \end{bmatrix}$$

The unknowns in Equation (3.90) are the displacement amplitudes  $\delta_i$  and the frequency  $p$ ;  $p$  has as many values as there are equations in the system, and for every value of  $p$  (eigenvalue) there corresponds a set of  $y$  (eigenvector).

We adopt an iterative procedure for the solution of Equation (3.90) and first of all rewrite the equations in the form:

$$\mathbf{FM} \Delta = \frac{1}{p^2} \Delta \quad (3.91)$$

We start with an assumed vector  $\Delta_0$ , thus:

$$\mathbf{FM} \Delta_0 = \frac{1}{p^2} \Delta_0$$

Putting  $\mathbf{FM} \Delta_0 = \Delta_1$ ,

$$\Delta_1 \approx \frac{1}{p^2} \Delta_0 \text{ giving } p^2 \approx \frac{\Delta_0}{\Delta_1}$$

We cannot form  $\Delta_0/\Delta_1$  since each  $\Delta$  is a column matrix, so we take the ratio of corresponding elements in  $\Delta_0$  and  $\Delta_1$  and form the ratio  $\delta_0/\delta_1$ . It is best to use the numerically greatest  $\delta$  for this purpose.

Continuing the process:

$$\mathbf{FM} \Delta_1 \approx \frac{1}{p^2} \Delta_1 \text{ giving } p^2 = \delta_1/\delta_2$$

$$= \Delta_2$$

and again:

$$\mathbf{FM} \Delta_2 \approx \frac{1}{p^2} \Delta_2$$

$$= \Delta_3 \text{ giving } p^2 = \delta_2/\delta_3$$

It can be shown that this iterative process converges to the largest value of  $1/p^2$  and hence yields the lowest (fundamental mode) frequency.

Applying the iterative scheme to the beam of Figure 3.28, and assuming:

$$\Delta_0 = \begin{bmatrix} 1 \\ 2 \\ 1 \end{bmatrix}$$

then,  $\Delta_1 = \mathbf{FM} \Delta_0$

$$\text{where } \mathbf{FM} = \frac{l^3}{256EI} \begin{bmatrix} 3.00 & 3.67 & 2.33 \\ 3.67 & 5.33 & 3.67 \\ 2.33 & 3.67 & 3.00 \end{bmatrix} \begin{bmatrix} wl/4 & 0 & 0 \\ 0 & wl/4 & 0 \\ 0 & 0 & wl/4 \end{bmatrix}$$

$$= \frac{wl^4}{1024EI} \begin{bmatrix} 3.00 & 3.67 & 2.33 \\ 3.67 & 5.33 & 3.67 \\ 2.33 & 3.67 & 3.00 \end{bmatrix}$$

$$\text{Thus: } \Delta_1 = \frac{wl^4}{1024EI} \begin{bmatrix} 12.67 \\ 18.00 \\ 12.67 \end{bmatrix} = \frac{12.67wl^4}{1024EI} \begin{bmatrix} 1.00 \\ 1.42 \\ 1.00 \end{bmatrix}$$

$$\text{Hence: } p_1^2 = \frac{\delta_0}{\delta_1} = \frac{2 \times 1024EI}{12.67 \times 1.42wl^4}$$

$$= 114 \frac{EI}{wl^4}$$

A second iteration gives:

$$\Delta_2 = \mathbf{FM} \Delta_1 = \frac{wl^4}{1024EI} \begin{bmatrix} 3.00 & 3.67 & 2.33 \\ 3.67 & 5.33 & 3.67 \\ 2.33 & 3.67 & 3.00 \end{bmatrix} \frac{12.67wl^4}{1024EI} \begin{bmatrix} 1.00 \\ 1.42 \\ 1.00 \end{bmatrix}$$

$$= 12.67 \left( \frac{wl^4}{1024EI} \right)^2 \begin{bmatrix} 10.54 \\ 14.91 \\ 10.54 \end{bmatrix}$$

Hence:

$$p_2^2 = \frac{\delta_1}{\delta_2} = \frac{12.67 \times 1.42wl^4}{1024EI} \times \frac{1}{12.67(wl^4/1024EI)^2 \times 14.91}$$

$$= 97.5 \frac{EI}{wl^4}$$

This result is very close to that produced by an exact method, i.e.  $97.41EI/wl^4$ .

### 3.8 Plastic analysis

#### 3.8.1 Introduction

The plastic design of structures is based on the concept of a *load factor* ( $N$ ), where

$$N = \frac{\text{Collapse load}}{\text{Working load}} = \frac{W_c}{W_w} \quad (3.92)$$

A structure is considered to be on the point of collapse when finite deformation of at least part of the structure can occur without change in the loads. The simple plastic theory is based on an idealized stress-strain relationship for structural steel as shown in Figure 3.29. A linear, elastic, relationship holds up to a stress  $\sigma_y$ , the *yield stress*, and at this value of stress the material is considered to be in a state of perfect plasticity, capable of infinite strain, represented by the horizontal line AB continued indefinitely to the right. For comparison the dotted line shows the true relationship.

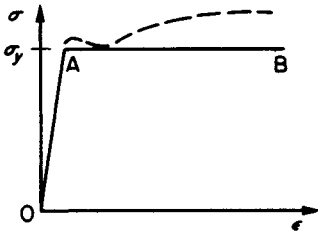

Figure 3.29

The term 'plastic analysis' is generally related to steel structures for which the relationship indicated in Figure 3.29 is a good approximation. The equivalent approach when dealing with concrete structures is generally termed 'ultimate load analysis' and requires considerable modification to the method described here.

The stress-strain relationship of Figure 3.29 will now be applied to a simple, rectangular section, beam subjected to an applied bending moment  $M$  (Figure 3.30).

Under purely elastic conditions, line OA of Figure 3.29, the stress distribution over the cross-section of the beam will be as shown in Figure 3.30(b) and the limiting condition for elastic behaviour will be reached when the maximum stress reaches the value  $\sigma_y$ . As the applied bending moment is further increased, material within the depth of the section will be subjected to the yield stress  $\sigma_y$  and a condition represented by Figure 3.30(c) will exist in which part of the cross-section is plastic and part elastic. On further increase of the applied bending moment ultimately condition (d) will be reached in which the entire cross-section is plastic. It will not be possible to increase the applied bending moment further and any attempt to do so will result in increased curvature, the beam behaving as if hinged at the plastic section. Hence, the use of the term *plastic hinge* for a beam section which has become fully plastic.

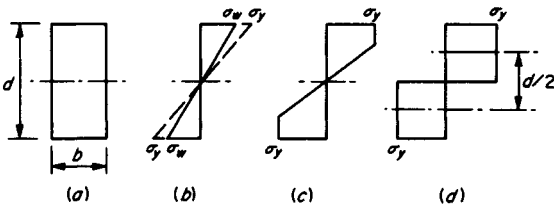

Figure 3.30

The moment of resistance of the fully plastic section is, from Figure 3.30(d):

$$M_p = b \frac{d}{2} \sigma_y \frac{d}{2} = \frac{bd^2 \sigma_y}{4}$$

$$= Z_p \sigma_w \tag{3.93}$$

where  $Z_p$  = plastic section modulus

In contrast, the moment of resistance at working stress  $\sigma_w$  is, from Figure 3.30(b):

$$M_w = b \frac{d}{2} \frac{\sigma_w}{2} \frac{2}{3} d = \frac{bd^2 \sigma_w}{6}$$

$$= Z_e \sigma_w \tag{3.94}$$

where  $Z_e$  = elastic section modulus

The ratio  $Z_p/Z_e$  is the shape factor of the cross-section. Thus the shape factor for a rectangular cross-section is 1.5.

The shape factor for an I-section, depth  $d$  and flange width  $b$ , is given approximately by:

$$\left( \frac{1 + x/2}{1 + x/3} \right)$$

where  $x = \frac{t_w d}{2 t_f b}$  and  $t_w$  and  $t_f$  are the web and flange thicknesses respectively

Values of plastic section moduli for rolled universal sections are given in steel section tables.

### 3.8.2 Theorems and principles

The definition of collapse, which follows from the assumed basic stress-strain relationship of Figure 3.29, has already been given. If the structural analysis is considered to be the problem of obtaining a correct bending moment distribution at collapse, then such a bending moment distribution must satisfy the following three conditions:

- (1) *Equilibrium condition*: the reactions and applied loads must be in equilibrium.
- (2) *Mechanism condition*: the structure, or part of it, must develop sufficient plastic hinges to transform it into a mechanism.
- (3) *Yield condition*: at no point in the structure can the bending moment exceed the full plastic moment of resistance.

In elastic analysis of structures where several loads are acting, e.g. dead load, superimposed load and wind load, it is permissible to use the principle of superposition and obtain a solution based on the addition of separate analyses for the different loads. In plastic theory the principle of superposition is not applicable and it must be assumed that all the loads bear a constant ratio to one another. This type of loading is called 'proportional loading'. In cases where this assumption cannot be made, a separate plastic analysis must be carried out for each load system considered.

For cases of proportional loading, the uniqueness theorem states that the collapse load factor  $N_c$  is uniquely determined if a bending moment distribution can be found which satisfies the three collapse conditions stated.

The collapse load factor  $N_c$  may be approached indirectly by adopting a procedure which satisfies two of the conditions but not necessarily the third. There are two approaches of this type:

- (a) We may obtain a bending moment distribution which satisfies the equilibrium and mechanism conditions, (1) and (2); in these circumstances it can be shown that the load factor obtained is either greater than or equal to the collapse load factor  $N_c$ . This is the 'minimum principle' and a load factor obtained by this approach constitutes an 'upper bound' on the true value.
- (b) We may obtain a bending moment distribution which satisfies the equilibrium and yield conditions, (1) and (3), and in these circumstances it can be shown that the load factor obtained is either less than or equal to the collapse load factor  $N_c$ . This is the 'maximum principle' and its application produces a 'lower bound' on the true value.

It should be observed that whilst method (a) is simpler to use in practice, it produces an apparent load factor which is either correct or too high and thus an incorrect solution is on the unsafe side. A most useful approach is to employ both principles

3/28 Theory of structures

in turn and obtain upper and lower bounds which are sufficiently close to form an acceptable practical solution.

3.8.3 Examples of plastic analysis

This section contains some examples of plastic analysis based on the minimum principle. The method employed is termed the 'reactant bending moment diagram method'.

**Example 3.5.** The structure is a propped cantilever beam of uniform cross-section, carrying a central load  $W$ , as shown in Figure 3.31(a). The bending moment distribution under elastic conditions is shown in Figure 3.31(b) and it should be noted that the maximum bending moment occurs at the fixed end A.

As the load  $W$  is increased, plasticity will develop first at end A. As the load is further increased, end A will eventually become fully plastic with a stress distribution of the type shown in Figure 3.30(d) and the bending moment at A,  $M_A$ , will equal  $M_p$  the fully plastic moment of the beam. Further increase of load will have no effect on the value of  $M_A$  but will increase  $M_B$  until it also reaches the value  $M_p$ . The resulting bending moment distribution will now be as shown in Figure 3.31(c).

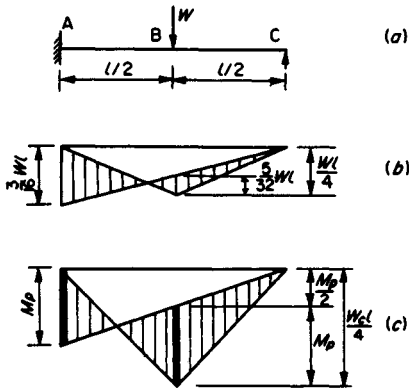

Figure 3.31

The geometry of the diagram produces a relationship between the load at collapse,  $W_c$ , and the plastic moment of resistance of the beam  $M_p$ , as follows:

$$\frac{W_c l}{4} = M_p + M_p/2$$

or:

$$W_c = 6 \frac{M_p}{l} \tag{3.95}$$

If the working load is  $W_w$  then the load factor is given by:

$$N = \frac{W_c}{W_w} \tag{3.96}$$

**Example 3.6.** This is again a propped cantilever but here the load is uniformly distributed (Figure 3.32(a)). At collapse the bending moment diagram will be as shown in Figure 3.32(b) with plastic hinges at A and C. It should be noted that C is not at the centre of the beam. The location of the plastic hinge at C

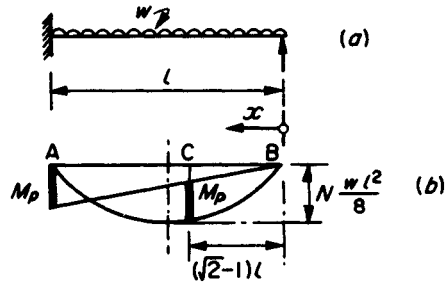

Figure 3.32

and the relationship between the load and the value of  $M_p$  may be obtained by differentiation as follows.

At C:

$$M_p = \left( N \frac{wlx}{2} - N \frac{wx^2}{2} \right) - M_p \frac{x}{l}$$

i.e.:

$$M_p = \frac{Nwlx(l-x)}{2(l+x)} \tag{3.97}$$

$$\frac{dM_p}{dx} = N \frac{wl\{(l+x)(l-2x) - x(l-x)\}}{(l+x)^2}$$

$$= 0 \text{ for } M_{p \max}$$

$$\text{Hence: } x^2 + 2xl - l^2 = 0$$

i.e.:

$$x = l(\sqrt{2}-1) = 0.414l$$

which locates the point C.

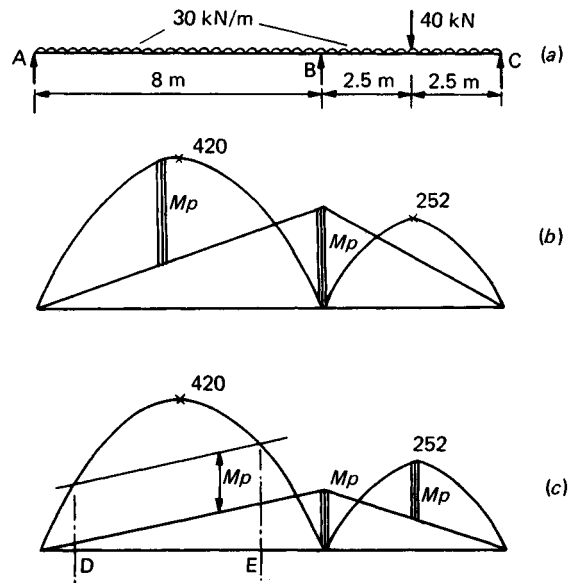

Figure 3.33

Also, substituting in Equation (3.97) for  $x$ :

$$M_p = \frac{Nwl^2(\sqrt{2}-1)}{2\sqrt{2}}(2-\sqrt{2})$$

$$= \left(\frac{Nwl^2}{8}\right) 4(3-2\sqrt{2})$$

$$= 0.686 \left(\frac{Nwl^2}{8}\right)$$

**Example 3.7.** A two-span continuous beam is shown in Figure 3.33. The loads shown are maximum working loads and it is required to determine a suitable universal beam (UB) section such that  $N=1.75$  with a yield stress  $\sigma_y=250$  N/mm<sup>2</sup>. Effects of lateral instability are ignored for the purposes of this example.

With factored loads, the free bending moments are:

$$1.75 \times 30 \times \frac{8^2}{8} = 420 \text{ kNm}$$

$$1.75 \times 30 \times \frac{5^2}{8} + 1.75 \times 40 \times \frac{5}{4} = 252 \text{ kNm}$$

For collapse to occur in span AB, Figure 3.33(b)

$$420 \times 0.686 = M_p = 288 \text{ kNm}$$

For collapse in BC, assuming the span hinge in BC to occur at the centre (Figure 3.33(c)):

$$252 = \frac{3}{2}M_p; \quad M_p = 168 < 288$$

Hence the beam must be designed for  $M_p = 288$  kNm

$$= Z_p \sigma_y$$

Hence:

$$Z_p = \frac{288 \times 10^6}{250 \times 10^3} \text{ cm}^3 = 1152 \text{ cm}^3$$

From section tables, select 406 × 178 UB 60 ( $Z_p = 1194 \text{ cm}^3$ ).

This design may be compared with elastic theory from which we obtain  $M_{\max} = 198$  kNm,  $Z_c = 1200 \text{ cm}^3$  (using  $\sigma_w = 165$  N/mm<sup>2</sup>). A suitable section would be 457 × 152 UB 67 ( $Z_c = 1250 \text{ cm}^3$ ) or, 406 × 178 UB 74 ( $Z_c = 1324 \text{ cm}^3$ ).

The plastic design may be improved by choosing different sections for spans AB and BC:

$$\text{For BC, } M_{\text{PBC}} = 168 \text{ giving } Z_p = \frac{168}{250} \times \frac{10^6}{10^3} = 672 \text{ cm}^3$$

Select 356 × 171 UB 45 ( $Z_p = 773.7 \text{ cm}^3$ )

For AB,  $M_{\text{PAB}} \cong 420 - \frac{1}{2}M_{\text{PBC}}$

$$= 420 - \frac{1}{2} \times \frac{773.7 \times 10^3 \times 250}{10^6}$$

$$= 420 - 96.7 = 323 \text{ kNm}$$

$$\therefore Z_p = \frac{323}{250} \times \frac{10^6}{10^3} = 1293 \text{ cm}^3$$

Select 406 × 178 UB 67.

The weights of steel used in the different designs may be compared.

First plastic design	780 kg
Elastic design	871 kg
Second plastic design	761 kg

As an alternative to the second plastic design the lower value of  $M_p$  could be used, based on collapse in BC (356 × 171 UB 45,  $Z_p = 773.7$ ,  $M_p = 193$  kNm), and flange plates welded on to the beam in the region DE, Figure 3.33(c).

The additional  $M_p$  required at the plated section

$$= 420 - \frac{3}{2} \times 193$$

$$= 130 \text{ kNm}$$

Using plates 150 mm wide top and bottom, the plastic moment of resistance of the plates is approximately:

$$2 \left( 150 \times t \times 250 \times \frac{356}{2} \right) \times 10^{-6}$$

$$= 13.4 t$$

where  $t$  = plate thickness in millimetres

Hence:

$$t = \frac{130}{13.4} \cong 10 \text{ mm}$$

**Example 3.8.** Here we consider the plastic analysis of a portal frame type structure as in Figure 3.34(a) and (b). At (a) the frame has pinned supports and at (b) fixed supports. A simple form of loading is used for illustration of the principles.

The frame is made statically determinate by the removal of  $H_A$  in both cases, and by the removal of  $M_A$  and  $M_E$  in case (b). The 'free' bending moment diagram is then as in diagram (c) and the reactant bending moment diagrams are as at (d) for  $H_A$  and at (e) for  $M_A$  and  $M_E$  combined. We now seek combinations of the diagrams which will satisfy the conditions of equilibrium, mechanism and yield (see page 3/27). We consider first the case of the two-hinged frame.

**Diagram (f)**

This is consistent with a pure sideway mode of collapse. From the geometry of the diagram:

$$M_p = \frac{Hh}{2} \tag{3.98}$$

The yield condition will be satisfied providing:

$$\frac{wl}{4} \leq \frac{Hh}{2} \tag{3.99}$$

**Diagram (g)**

This is a combined mechanism involving collapse of the beam and sideway. From the geometry of the diagram:

At D:

$$M_p = Hh \mp H_A h$$

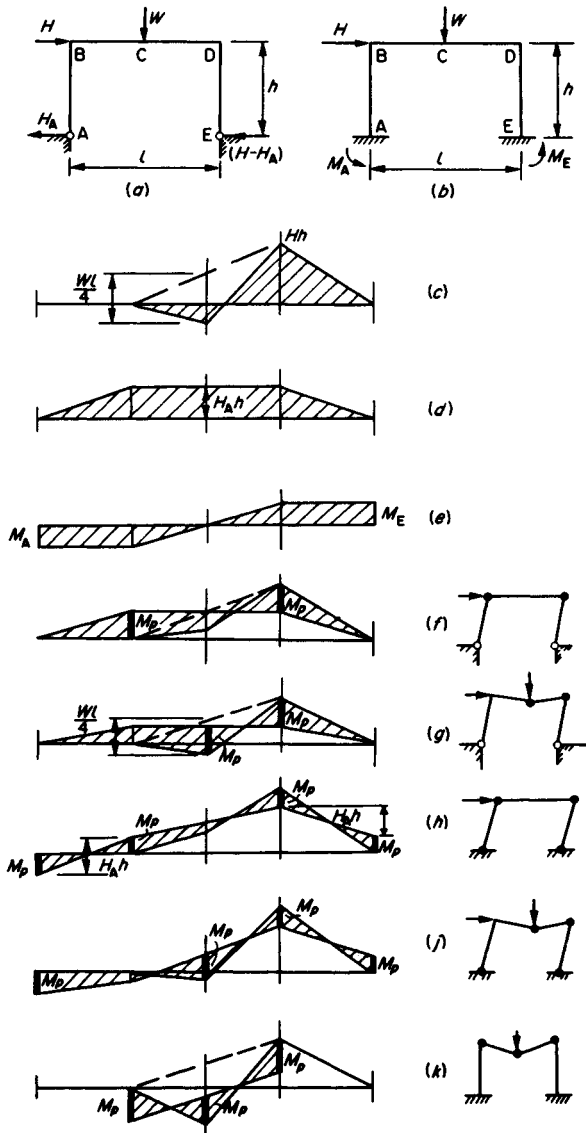

Figure 3.34

At C:

$$M_p = \frac{Wl}{4} - \frac{Hh}{2} \pm H_A h$$

Adding:

$$2M_p = \frac{Wl}{4} + \frac{Hh}{2}$$

or:

$$M_p = \frac{Wl}{8} + \frac{Hh}{4} \tag{3.100}$$

In the case of the frame with fixed feet, there are three possible

modes of collapse. The corresponding bending moment diagrams are constructed at (h), (j) and (k) and the results are as follows:

Diagram (h):

$$M_p = \frac{H_A h}{2}$$

$$M_p = Hh - H_A h - M_p$$

Hence:

$$M_p = \frac{Hh}{4} \tag{3.101}$$

Diagram (j):

$$M_p = \frac{Wl}{4} - \frac{Hh}{2} \pm H_A h$$

$$M_p = Hh \mp H_A h - M_p$$

Adding:

$$3M_p = \frac{Wl}{4} + \frac{Hh}{2}$$

or:

$$M_p = \frac{Wl}{12} + \frac{Hh}{6} \tag{3.102}$$

Diagram (k)

This mode is the same as the collapse of a fixed end beam; the columns are not involved in the collapse apart from providing the resisting moment  $M_p$  at B and D. From the geometry of the diagram:

$$M_p = \frac{Wl}{8} \tag{3.103}$$

**Example 3.9.** Here we consider a pitched roof frame, a structure which is eminently suitable for design by plastic methods. The frame is shown in Figure 3.35(a). The given loads are already factored and we are to find the required section modulus on the basis of a yield-stress  $\sigma_y = 280 \text{ N/mm}^2$ , neglecting instability tendencies and the reduction in plastic moment of resistance due to axial forces.

The bending moment diagram at collapse is shown in Figure 3.35(b). The free bending moment diagram, EFGH, is drawn to scale after evaluating values of moment at intervals along the rafter members. The reactant line ( $H_x$  diagram) is then drawn by trial and error so that the maximum moment in the region BC is equal to the moment at D. This moment is the required  $M_p$  for the frame and is found to be:

$$M_p = 52 \text{ kNm} = \sigma_y Z_p$$

from which:

$$Z_p = \frac{52 \times 10^3 \times 10^3}{280 \times 10^3} = 186 \text{ cm}^3$$

Horne<sup>8</sup> and Baker and Heyman<sup>9</sup> should be consulted for a more

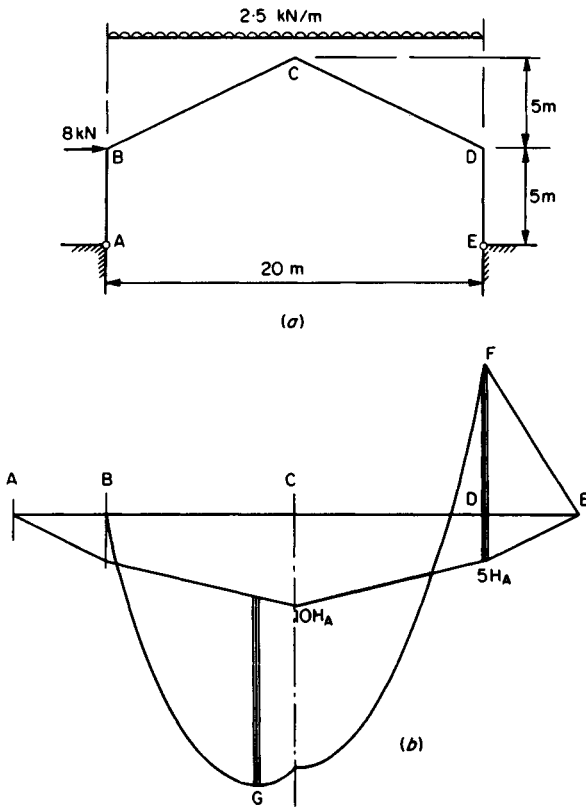

Figure 3.35

detailed study of plastic analysis. Among the topics deserving of further study are:

- (1) Use of the principle of virtual work in obtaining relationships between applied loads and plastic moments of resistance.
- (2) Effects of strain hardening.
- (3) Evaluation of shape factors for various cross-sections.
- (4) Application of the maximum principle in obtaining lower bounds.

- (5) Numbers of independent mechanisms.
- (6) Shakedown.
- (7) Effects of axial forces.
- (8) Moment carrying capacity of columns.
- (9) Behaviour of welded connections.

### References

- 1 Jenkins, W. M (1982) *Structural mechanics and analysis level IV/V*. Thomas Nelson/Van Nostrand Reinhold, London.
- 2 Coates, R. C., Coutie, M. G. and Kong, F. K. (1972) *Structural analysis*. Nelson, London.
- 3 Ghali, A. and Neville, A. M. (1978) *Structural analysis*. 2nd edn. Chapman and Hall, London.
- 4 Zeinkiewicz, O. C. (1977) *The finite element method*. McGraw-Hill, Maidenhead.
- 5 Desai, C. S. (1977) *Elementary finite element methods*. Prentice-Hall, New Jersey.
- 6 PAFEC (1978) PAFEC 75, Pafec Ltd, Pafec House, 40 Broadgate, Beeston, Nottingham NG9 2FW.
- 7 Warburton, G. B (1976) *The dynamical behaviour of structures*, 2nd edn. Pergamon Press, Oxford.
- 8 Horne, M. R. (1979) *Plastic theory of structures*, 2nd edn. Pergamon Press, Oxford.
- 9 Baker, J. and Heyman, J. (1969) *Plastic design of frames*. Cambridge University Press, Cambridge.

### Bibliography

- Bhatt, P. (1981) *Problems in structural analysis by matrix methods*. The Construction Press, London.
- Cheung, Y. K. (1976) *Finite strip method in structural analysis*. Pergamon Press, Oxford.
- Cheung, Y. K. and Yeo, M. F. (1979) *A practical introduction to finite element analysis*. Pitman, London.
- Dawe, D. J. (1984) *Matrix and finite element displacement analysis of structures*. Clarendon Press, Oxford.
- Graves Smith, T. R. (1983) *Linear analysis of frameworks*. Ellis Horwood, Chichester.
- Harrison, H. B. (1980) *Structural analysis and design: some mini-computer applications*. Pergamon Press, Oxford.
- Jenkins, W. M., Coulthard, J. M. and de Jesus, G. C. (1983) *BASIC computing for civil engineers*. Van Nostrand Reinhold, London.
- McGuire, W. and Gallagher, R. H. (1979) *Matrix structural analysis*. Wiley, Chichester.



# Civinnovate

Discover, Learn, and Innovate in Civil Engineering